

**RULES
FOR TECHNICAL SUPERVISION OF
SEA-GOING SHIPS**

Part 22 – POLLUTION PREVENTION
January 2026

CROATIAN REGISTER OF SHIPPING

Hrvatska (Croatia) • 21000 Split • Marasovića 67 • P.O.B. 187
Tel.: (...) 385 (0)21 40 81 11
Fax.: (...) 385 (0)21 35 81 59
E-mail: tech.coord@crs.hr
web site: www.crs.hr

RULES FOR TECHNICAL SUPERVISION OF SEA-GOING SHIPS
Part 22 – POLLUTION PREVENTION

are considered to be applicable from 1st January 2026

GENERAL TERMS AND CONDITIONS

(March 2022)

Article 1 GENERAL

1.1 CROATIAN REGISTER OF SHIPPING (hereinafter: the *Register*) shall at all times remain an independent contractor and neither the *Register* nor any of its officers, surveyors, auditors, inspectors, agents, appointers, officers or managers shall act as an employee, servant or agent of any other party in the performance of the Services rendered by the *Register*.

1.2 The *Register* acts as a service provider. The Services provided by the *Register* cannot be construed as a commitment by the *Register* to achieve any result or as a warranty.

1.3 The provision of Services is subject to these General Terms and Conditions. No other terms and conditions shall apply, either expressly or by implication, unless expressly agreed in writing between the Parties.

1.4 These General Terms and Conditions shall be incorporated into, or referred to in any Contract and shall prevail over and exclude any other terms and conditions that the Client may wish to impose.

Any amendments to and/or deviations from these General Terms and Conditions, as well as any additional terms and conditions of the Client, shall be binding or valid only if set forth in writing and duly signed by the authorised representatives of both Parties.

1.5 The invalidity of one or more provisions of these General Terms and Conditions shall not affect the remaining provisions.

1.6 The Client acknowledges that the latest version of these General terms and Conditions and the latest version of applicable Rules apply to the Services provided by the *Register*.

1.7 Definitions in these General Terms and Conditions take precedence over other definitions that may appear in other documents issued by the *Register*.

1.8 The Client should at all times be aware of the provisions of these General Terms and Conditions, as they may be further amended, with their latest up to date version available on the web site of the *Register*.

Article 2 DEFINITIONS

2.1 **Certificate** means either a class certificate or statutory certificate, statement, attestation, statement of compliance, and a report following the Services provided by the *Register*.

2.2 **Certification** means the activity of certification in application of international and national standards and international industry practice provided by the *Register*.

Certification is an appraisal given by the *Register* to the Client and cannot be construed as an implied or express warranty of safety, fitness for purpose, seaworthiness of the vessel or its value for sale, insurance or chartering.

The purpose of Certification is to provide classification and statutory services and assistance to the maritime industry, Flag State Administrations, and regulatory authorities relating to maritime safety and pollution prevention.

2.3 **Classification** includes all activities and Services provided by the *Register* in accordance with the Rules. Classification may or may not be accompanied by the issuance of a Certificate of class with reference to the Rules.

Certificate of class is valid only if issued by the *Register*.

However, Certificate of class should not be construed as a guarantee of the safety, fitness for purpose or seaworthiness of the vessel. It is merely an attestation that the vessel complies with the Rules developed and published by the *Register*.

In addition, the *Register* is not a guarantee of the safety of life or property at sea or the seaworthiness of a vessel because, although the classification of a vessel is based on the assumption that the vessel will be properly loaded, operated, and maintained by competent and qualified personnel, the *Register* has no control over how a vessel is operated and maintained between the periodic surveys it conducts.

2.4 **Statutory certification** means certification made by the *Register* on behalf of the Flag State Administrations when and to the extent that the *Register* has been authorised to do so by the respective Flag State.

Statutory certification and services include the assessment of vessels registered by the Flag State and/or ship management companies to determine whether such ships/companies comply with the applicable requirements of international conventions, codes and national legislation, and the issuance of, or assistance in the issuance of, the appropriate certificates and documents.

Statutory certification includes, but is not limited to, certification, survey, and issuance of statutory certificates on behalf of the Flag State.

In cases where the *Register* acts on behalf of Flag State Administrations, the *Register* shall follow guidance issued by IMO (Resolutions, Circulars, etc.) or by IACS through Unified Interpretations (UI), unless otherwise directed by the Flag State.

2.5 **Client** means the shipowner, company, shipyard and/or party requesting Services or taking ownership of a classed vessel. In cases where shipowners have authorized another party to operate the vessel on their behalf, that party shall be considered as the company.

In addition to the above the Client means the person and/or entity that has requested Services from the *Register* and that has entered into a Contract or an agreement for Services with the *Register*.

2.6 **Parties** means the *Register* and Client together.

2.7 **Party** means the *Register* or the Client.

2.8 **Contract** means the contract in the form of a written agreement between the Client and the *Register* requesting Services, including these General Terms and Conditions and the Rules.

The provisions related to the Contract in these General Terms and Conditions shall apply even if there is no written agreement between the Client and the *Register*.

The Client may request the *Register* in writing to make a change to the contracted Services. However, the *Register* shall not be obligated to accept or execute any such change until a written agreement has been signed with the Client regarding the compensation and the possible impact of the change on the schedule as an addendum to the originally contracted Services.

2.9 **Services** shall mean the services specified in 2.2, 2.3 and 2.4, but also other services related to certification, classification and statutory certification, such as, but not limited to: ISM Code certification, ISPS Code, MLC 2006 certification, fuel oil consumption reporting, IHM certification, approval of manufacturers and service providers, certification of materials and products, training activities, conformity assessment, and any other relevant activities such as third party inspections, testing, shore and shipboard trials.

The Services provided by the *Register* are performed on a random basis and in no case include a full inspection of all items.

The *Register* shall provide the Services in accordance with related Contract(s), the provisions of these General Terms and Conditions, Rules, the international and national standards, the international conventions, the EU Regulations, the Flag State requirements and the industry practices applicable to the particular Service and always assuming that the Client is aware of these standards and the industry practices.

When providing Services, the *Register* does not guarantee the accuracy of the information or advice provided.

In providing Services, the *Register* does not assess compliance with standards other than the Rules, international and national standards, international conventions, EU regulations, Flag State requirements and industry practice, to the extent agreed in writing or specified in the Contract.

2.10 The *Register* means the Croatian Register of Shipping, an entity organized and existing under Croatian law, which, according to the Law on the Croatian Register of Shipping (Official Gazette No. 1996/81, 2013/76 and 2020/62) and the Charter of the *Register*, is an independent, not-for-profit, but public welfare oriented, public foundation that performs tasks:

- classification of sea-going ships,
- statutory certification of sea-going ships on behalf of the Flag State Administrations,
- classification of inland navigation vessels,
- statutory certification of inland navigation vessels,
- statutory certification of recreational crafts,
- certification of materials and products,
- conformity assessment of recreational crafts,
- conformity assessment of marine equipment,
- conformity assessment of pressure vessels,
- certification/registration of quality management systems.

2.11 **Vessel** means a ship, vessel, unit or offshore structure of any kind, whether or not connected to the shore or sea/river bed, located at sea or in inland waters and intended for transportation or special operations on the water, as decided by the *Register*.

2.12 **Rules** means the Rules for the classification, guidelines, instructions, or other documented evidence of the *Register* related to the Services provided.

The competent interpretation of the requirements specified in the Rules or other regulations published by the *Register* shall be the exclusive responsibility of the *Register's* Head Office, notwithstanding any possible different interpretations by other parties.

In cases where the Rules do not contain detailed requirements, the specific approval by the *Register* shall be based on the principles of the Rules and shall ensure a safety standard equivalent to that of the Rules.

Article 3 RESPONSIBILITIES

3.1 It is the Client's responsibility to ensure that all surveys required for vessel's class maintenance are conducted in a timely manner and in accordance with the Rules.

3.2 The *Register* may suspend or withdraw the vessel's existing Certificate of class in the event of serious deficiencies and replace it with a new Certificate of class with a shortened period of validity during which the deficiencies are to be rectified.

In addition, the *Register* shall suspend or withdraw a vessel's Certificate of class if the deficiencies are of such a magnitude as to endanger the class of the vessel, its safety and integrity, the safety of the crew, passengers, or the marine environment, and shall require that the vessel is to be inspected at the first port of call where the necessary repairs are to be carried out.

3.3 The Client should inform the *Register*:

- (i) in the event of a change in the intended use of a vessel, a conversion and alteration of the hull, machinery installations and other equipment affecting the Class of the vessel assigned by the *Register*. Conversions and alterations must be made under the supervision of the *Register* and must comply with the requirements of the Rules and/or additional requirements of the *Register*,
- (ii) in cases where the vessel has been damaged to such an extent that the Class of the vessel is likely to be affected and the safety and integrity of the vessel is likely to be compromised. In such cases, the vessel must be surveyed at the first port of call or as further directed by the *Register*. The survey shall be to the extent deemed necessary by the *Register*, by taking into account the extent of the damage.
- (iii) in cases where class-related deficiencies and/or defects are found as a result of a Flag State inspection or Port State Control. Should the Client fail to notify the *Register* of the detention of the vessel by Port State Authorities due to class related deficiencies, the *Register* reserves the right to suspend or withdraw the Certificate of class.

3.4 The *Register* shall have full control over Certificates issued and may suspend or withdraw a Certificate at any time in its sole discretion if the Client fails to comply with the following requirements set forth in the *Rules for the Classification of Ships, Part 1 - General Requirements, Chapter 1 - General Information*, as applicable:

- (i) para. 5.3 - *Maintenance of the validity of Certificate of Class*,
- (ii) para. 5.4 - *Period of Validity*,
- (iii) para. 5.5 - *Extension of the Period of Validity*,
- (iv) para. 5.6 - *Suspension and Reinstatement of Class in the Case of Overdue Surveys*, and
- (v) para. 5.7 - *Withdrawal of Class*.

3.5 The *Register* may suspend or withdraw a Certificate at any time in its sole discretion if the Client fails to comply with the following requirements set forth in the *Rules for the Classification of Inland Navigation Vessels, Part 1 - Classification and Surveys, Chapter I - Principles of Classification*, as applicable:

- (i) para. 2.8 - *Maintenance of the Validity of the Certificate of Class*,
- (ii) para. 2.9 - *Extension of validity of the Certificate of Class*, and following requirements set forth in the *Rules for the Classification of Inland Navigation Vessels, Part 1 - Classification and Surveys, Chapter II - Classification*, as applicable:
- (iii) para. 2.1 - *Suspension of Class*,
- (iv) para. 2.2 - *Withdrawal of Class*.

3.6 In addition to clauses 3.2, 3.4 and 3.5 of this Article, the *Register* reserves the right to terminate the Services and related Contract in the event of a breach of the provisions of these General Terms and Conditions.

3.7 If the Client fails to provide the *Register* with the required access or information at the agreed times or fails to prepare for the Service in a timely manner, the *Register* may suspend the provision of the Service until it receives the Client's instructions for access and/or the required information.

The *Register* shall not be liable for the consequences of such suspension, and the Client shall be responsible for the *Register's* additional fees and other unnecessary costs and expenses incurred by the *Register*.

3.8 The Client is obliged to perform timely payments of the invoices for provided Services. However, the *Register* may retain or withhold any Service or Certificate to the Client in the case of outstanding payments, whether mutually related or not, arising out of the entire business relationship with the Client.

Article 4

HEALTH, SAFETY AND ENVIRONMENT

4.1 Both the *Register* and the Client shall apply reasonable standards to promote safety, health, and environmental protection and to provide a safe working environment for their personnel.

4.2 The Client shall provide the *Register* with all access and information necessary for the safe and efficient performance of the requested Services as required by the Rules.

4.3 During the survey, personnel of the *Register* should have secure access to all work that directly or indirectly affects the Service.

4.4 The *Register* has the right to refuse to conduct an activity or visit an area or site if the *Register* in its sole discretion, believes that relevant risks are unacceptable or are not adequately addressed, contained, or otherwise mitigated.

Such a decision shall suspend the obligations of both Parties under the Contract without incurring any liability or penalty until the Parties agree on how to proceed.

Article 5

THIRD PARTIES AND SUBCONTRACTORS

5.1 Each specific Contract, including any Certificates issued, relates specifically to the Client, and no rights, obligations, interests, claims, benefits or Certificates issued shall extend to any third party without the prior written consent of the *Register*.

5.2 The Client shall not be entitled to grant any right to use the Certificates to any third party without the prior written consent of the *Register*.

5.3 The Client shall not without *Register's* consent, cede, assign, transfer, subcontract or deal in any manner with all or any of its rights or obligations under any Service and related Contract.

5.4 With regard to third party rights to access information and Certificates under confidentiality clause reference is to be made to Article 9.

Article 6

TAXES

6.1 Each Party shall be responsible for and shall bear all taxes, duties or similar governmental charges levied or imposed on any activity of that Party.

6.2 Prices, fees, rates, or remuneration are exclusive of any form of sales tax, value added tax, administrative fees and services tax and/or other similar taxes, including any surcharges. If any such indirect tax is or becomes applicable to the Services provided under the Contract, the Client shall be responsible for the payment of such indirect taxes.

Article 7

PAYMENT OF INVOICES

7.1 The provision of Services by the *Register*, whether complete or not, shall include payment of fees thirty (30) days after issuance of the invoice for the portion of the Services performed.

7.2 In the event that the Client fails to meet the requirements for payment in accordance with the instalments and terms of payment contained herein, the *Register* reserves the right to charge the Client with the interest rate in accordance with the applicable laws of the Republic of Croatia.

7.3 If the Client disputes an invoice or part of an invoice, the Client shall notify *Register* thereof in writing without undue delay. If no notification is received by the due date, Client shall be deemed to have accepted the invoice in full. If only part of an invoice is disputed, the undisputed amount must be paid by the due date.

Consequently, no disputes arising between the *Register* and the Client shall interfere with prompt payment of invoices by the Client. Any rights of lien or retention in favour of the Client or otherwise, are hereby excluded.

7.4 In the event of cancellation of all or part of the Services prior to their final completion, the Client shall pay all costs incurred by the *Register* on pro-rata basis for the portion of the Services provided to date. In such event, the *Register* will not claim the Client for loss of profit or reduced income. All reasonable costs directly attributable to the early termination and all amounts due to the *Register* at that time shall become immediately due and payable.

7.5 In the event of termination of the Service and related Contract, the *Register* shall be entitled to retain any payments, deposits or prepayments of fees made by the Client prior to the date of termination up to the amount to which the *Register* is entitled.

Article 8

TERMINATION

8.1 The Parties shall have the right to terminate the Services and the related Contract(s) by written notice to the other Party, and without prejudice to Article 7, in the following cases:

- (i) if the other Party commits a material breach of these General Terms and Conditions and/or the Contract and fails to rectify such breach in accordance with clause 8.4 of this Article,
- (ii) if the other Party becomes insolvent, is unable to pay its debts as they become due, or becomes subject to bankruptcy proceedings, administration, receivership, dissolution, liquidation, winding up or otherwise ceases to carry on its business; or
- (iii) for convenience, after giving the other Party thirty (30) days' prior written notice of termination.

8.2 The Classification issued for the relevant vessel and the Certificates previously issued shall remain valid until the effective date of termination or, in the event of such termination, immediately, subject to compliance with Article 3 and Article 7.

8.3 If, in the reasonable opinion of the *Register*, the Client breaches or is suspected of breaching Article 14 or Article 15, the *Register* shall have the right to terminate the Service and related Contract with immediate effect.

8.4 Notwithstanding the provisions of clause 8.1 of this Article, the Party intending to terminate Services for non-compliance or breach of the provisions of these General Terms and Conditions shall notify the other Party of the non-compliance or violation of the provisions of these General Terms and Conditions and set a reasonable deadline of 15 (fifteen) days for the other Party to remedy the breaches of the provisions of these General Terms and Conditions.

If the Party fails to remedy the breaches of the provisions of these General Terms and Conditions within the aforementioned period, the other Party shall have the right to terminate Services without further notice.

8.5 Termination of the Service and related Contract pursuant to the provisions of these General Terms and Conditions shall not give either Party the right to claim any additional compensation, indemnity or reimbursement from the other Party as a result of such termination, but such termination shall not affect any rights or remedies available to a Party at the time the termination becomes effective or any obligations or liabilities incurred by a Party.

Article 9 CONFIDENTIALITY

9.1 The Parties agree to keep confidential all facts, data, information, etc. related to the other Party's business that they have learned in the course of providing Services. Such information and data shall not be disclosed by the Parties to any third party and shall not be used or misused to the detriment of the other Party.

9.2 The *Register* will keep confidential any data, plans or other technical information received from the Client and will not disclose it to any third party outside the *Register*, unless authorised by the Client. This obligation shall continue to apply after termination of the Services. This obligation shall not apply to any data, plans or other technical information that was in the possession of the *Register* prior to being disclosed to the *Register* by or on behalf of the Client, or that becomes publicly available through no fault of the *Register*, or is otherwise provided to the *Register* by an independent source that is under no obligation of confidentiality to the *Register*.

9.3 Certificates issued by the *Register* to the Client as a result of the Services provided shall not be covered by the confidentiality Article.

Notwithstanding the foregoing, the Client shall be entitled to disclose any data to its affiliates involved in the transactions related to the Services or the Client's core activities.

9.4 Notwithstanding clause 9.1 and clause 9.2 of this Article, the *Register* shall have the right to disclose the Confidential Information to the following parties if required by regulations of:

- (i) authorised representatives of the Flag State Administration,
- (ii) authorised audit teams (i.e., accreditation body or EC auditors),
- (iii) the International Association of Classification Societies (IACS),
- (iv) a court of competent jurisdiction, government agency, or other relevant public authority, in accordance with applicable law, court order, or other public regulation.

9.5 The Client acknowledges that the *Register* is required to provide access to information to the EU Commission or any person acting on its behalf in accordance with applicable EU requirements and that the Client shall give the EU Commission with unrestricted access to the vessels for the purpose of inspection.

9.6 The obligations in this Article shall survive the conclusion of the Service or the termination of related Contract and shall continue for as long as the relevant information remains confidential.

Article 10 INTELLECTUAL PROPERTY

10.1 Each Party shall be the sole owner of all rights to its Intellectual Property created before or after the effective date of these General Terms and Conditions, whether or not associated with any Contract between the Parties.

10.2 The Intellectual Property developed by the *Register* for the provision of the Services, including but not limited to drawings, calculations and reports, shall remain the exclusive property of the *Register*.

Article 11 PROFESSIONAL ETHICS

11.1 Each of the Parties warrants that, with respect to the matters contemplated herein, neither it nor its affiliates has made or will make, directly or indirectly, any offer, payment, gift or authorization of money to any government official or employee, political party, public official or candidate for the benefit or advantage thereof.

11.2 In providing the Services, the *Register* shall strictly adhere to the requirements of its Code of Ethics relating to business activities.

Article 12 FORCE MAJEURE

12.1 For the purposes of these General Terms and Conditions, the term "Force Majeure" includes any event that directly or indirectly prevents the Parties from fulfilling their obligations due to events beyond their control, such as: strikes, wars, riots, piracy, civil commotion, malicious damage, pandemic, compliance with laws or government orders, rules, regulations or directives, sanctions and embargoes, accidents, defects of plants or machinery, seizures, fires, floods, storms and the like.

12.2 If either Party is prevented or delayed from performing its obligations by Force Majeure, such Party shall promptly notify the other Party in writing of the circumstances of the Force Majeure and its influence and, after such notification, shall not be liable for performance of any obligations prevented by the influence of the Force Majeure during its duration. Upon termination of the influence of the Force Majeure, the same Party should proceed with the planned activities in order to fulfil its obligations.

12.3 If one of the Parties is prevented by Force Majeure in its activities and fulfilment of its obligations and this event lasts continuously for three (3) months, the other Party shall be entitled to terminate the Service and related Contract without liability.

12.4 Neither of the Parties shall be liable for non-compliance with these General Terms and Conditions due to Force Majeure. If one of the Parties is prevented from fulfilling its obligations under these General Terms and Conditions due to Force Majeure, it shall immediately notify the other Party in writing within a reasonable period of time, stating the reasons for the Force Majeure and providing relevant evidence, if any.

Article 13 INDEMNIFICATIONS

13.1 Each Party shall indemnify the other Party against all claims arising out of the performance of the Services in respect of bodily injury, illness or death of any of its employees or other representatives and in respect of loss of or damage to the Party's property.

This provision shall apply whether or not the damage is caused or contributed to by the negligence of the other Party. Both Parties are obliged to take out separate insurances for these liabilities.

13.2 The Client shall indemnify the *Register* from and against all claims arising from the Client's violation of the provisions of these General Terms and Conditions and from the misuse of the Certificates issued by the *Register*.

13.3 The Client shall indemnify the *Register* against any financial responsibility or amounts arising from non-payment, late payment or payment of withholding taxes to the non-relevant tax authority or any other relevant governmental body.

13.4 Each Party shall notify the other Party without undue delay as soon as it becomes aware of any incident that could give rise to a claim against the other Party in respect of the Service provided and related Contract.

Article 14 ANTI-CORRUPTION

14.1 Each Party agrees that in performing its obligations under any Service, it will ensure that its affiliates, employees and/or agents, subsidiaries, subcontractors, consultants, and any other persons providing Services will:

- (i) comply with all applicable anti-bribery and anti-corruption laws (collectively, Anti-Bribery Laws) and, in particular, do not, directly or indirectly, offer, promise, grant, authorise the payment of, or confer any financial or other benefit on any public or government official:
 - to a public or governmental official to obtain or retain business with the intent to influence such official in his or her capacity as an official, if such official is not permitted or required by written law to be influenced by the offer, promise or gift; or
 - to another person with the intent to induce or reward the improper performance of a function or activity or for any other illegal purpose,
- (ii) maintain adequate systems and procedures designed to prevent activities, practises, or conduct in connection with services that would constitute an offence under an anticorruption law; and
- (iii) take reasonable steps to prevent similar acts by customers, contractors, subcontractors, agents and other third parties, persons under its control or influence.

14.2 Any failure by a Party to comply with or ensure compliance with its obligations under this Article shall, notwithstanding anything to the contrary in these General Terms and Conditions, be deemed a breach of these General Terms and Conditions which shall entitle the other Party to suspend and/or terminate the Services by notice in writing with immediate effect without further liability to the other Party except for any liability which may have arisen prior to the date of termination or suspension (as the case may be).

14.3 If a Party elects to suspend the provision of Services under these General Terms and Conditions pursuant to this Article, it shall have the sole and absolute discretion to determine:

- (i) when it will resume performance (if at all); and
- (ii) extend the period for performance of its obligations under the Services in its sole discretion.

Article 15 SANCTIONS

15.1 Each Party shall conduct all activities in compliance with all laws, statutes, rules, economic and trade sanctions (including, but not limited to, U.S. sanctions and EU sanctions) and regulations applicable to such Party, including, but not limited to: child labour, forced labour, collective bargaining, discrimination, abuse, working hours and minimum wages, anti-bribery, anti-corruption, copyright and trademark protection, personal data protection.

15.2 Each Party hereby represents and warrants that it is not or will not be subject to any economic or trade sanctions ("Sanctions") imposed by the United States of America, the European Union, the United Kingdom, any EU Member State, or the United Nations with respect to any country and/or by any sanction giver with respect to any company/individual.

15.3 Each Party represents and warrants that it will strictly comply with all Sanctions.

15.4 Nothing in these General Terms and Conditions shall be construed as causing or obligating either Party to act or refrain from acting in a manner inconsistent with, punishable by, or prohibited by any Sanctions.

15.5 Neither Party shall be obligated to perform any obligation arising under these Terms and Conditions (including, without limitation, the obligation to):

- (i) perform, deliver, accept, sell, purchase, pay or receive any funds to, from or through any person or entity; or
- (ii) engage in any other action whatsoever,
if doing so violates or is inconsistent with sanctions and/or recommendations of international (intergovernmental) organisations to combat the financing of terrorism and other criminal activities and/or money laundering or exposes such Party to investigation or penalties.

15.6 In the event that a Party breaches any Sanctions or the Party's Business and/or Transactions arising out of or in connection with these General Terms and Conditions breach any Sanctions or otherwise violate the recommendations of one or more international (intergovernmental) organisations for combating the financing of terrorism and other criminal activities and/or money laundering, the other Party shall be entitled to terminate these General Terms and Conditions by written notice with immediate effect without incurring any liability to the other Party, except for liabilities (if any) incurred prior to the date of termination.

Article 16 LIABILITY

16.1 The *Register* is not, and cannot be considered as, an underwriter, consulting engineer, naval architect, shipbuilder, shipowner, or ship management company, nor can it assume the obligations and responsibilities associated with such functions, although the *Register's* experience may enable it to respond to inquiries about matters not covered by its Rules, policies, instructions, or other documented evidence.

16.2 The practices and procedures of the *Register* shall be selected by the *Register* in its sole and absolute discretion based on its experience and knowledge and in accordance with generally accepted professional standards in the relevant field of classification societies.

16.3 Nothing herein contained shall release any designer, naval architect or engineer, shipbuilder or manufacturer, shipyard, vendor, supplier, contractor or subcontractor, repairer or owner, from any information, report, certificate or similar document issued in connection with the provision of Services by the *Register*, operator, manager or other person or entity from any express or implied warranty or other contractual obligation or responsibility, or from any negligent act, error or omission of any kind whatsoever, nor shall they create any right, claim or benefit for any third party.

16.4 The *Register* shall exercise due care in the selection or appointment of its surveyors and all other employees whose presence and work is necessary for the provision of the Services.

16.5 If any person or entity using the Services of the *Register* suffers any loss, damage or expense that is or is shown to have been caused by a negligent act, omission or error of the *Register's* officers, surveyors, auditors, inspectors, agents, appointers, officers or managers, or those purporting to act in the name of and on behalf of the *Register*, or a negligent inaccuracy, advice, report or evidence given by or in the name of or/and on behalf of the *Register*, then the liability of the *Register* is limited in respect of any direct or indirect claim shall be limited to an amount not exceeding five times the fee charged or to be charged by the *Register* for the relevant Service.

16.6 Any liability for consequential damages is expressly excluded.

For purposes of this clause, consequential damages include, without limitation:

- (i) indirect or consequential damages,

- (ii) loss and/or delay of production, loss of products, loss of use, loss of bargain, loss of revenue, loss of profit or anticipated profit, loss of business and business interruption, in each case directly or indirectly.

16.7 The Parties are not entitled to assign the performance of obligations under these General Terms and Conditions or parts thereof to third parties without the prior written consent of the other Party.

16.8 If during the term of the Contract, there is a transfer of function due to change of status (merger, acquisition, division, etc.), all obligations and rights under these General Terms and Conditions and associated Contract will be transferred to the legal successor of the Party concerned.

Article 17 GOVERNING LAW AND RESOLVING OF DISPUTES

17.1 These General Terms and Conditions and any dispute or claim between the Parties arising from or in connection with it, or the Services provided hereunder, will be governed and interpreted in accordance with the English law.

17.2 The Parties shall use their reasonable efforts to resolve any claim or dispute arising in relation to rendered Service by negotiations within a reasonable time.

17.3 Should the Parties fail to resolve any claim or dispute by negotiations, the dispute shall be exclusively subject to the jurisdiction of the Permanent Arbitration Court with the Croatian Chamber of Economy in Zagreb, Republic of Croatia.

17.4 The Parties agree to keep the any arbitration proceedings confidential.

17.5 Notwithstanding the above, any claim not presented within three (3) months of the completion of the particular Services, or within three (3) months of the date when the events which are relied on were first discovered by the Client, shall be deemed waived and absolutely time barred.

17.6 Any objections against the line adopted by any of the *Register's* servants in fulfilling their duties or against the conclusions reached are to be raised to the *Register* by the Party as soon as possible.

If the Party is not satisfied with the final conclusions and interpretations by the *Register* the arbitration lays upon the Commission for appeal for Classification and Statutory certification of ships, which is to be formed according to the Regulation 39 of the Charter of the *Register*.

**REVIEW OF AMENDMENTS IN RELATION TO PREVIOUS
EDITION OF THE RULES**

RULES FOR TECHNICAL SUPERVISION OF SEA-GOING SHIPS

Part 22 - POLLUTION PREVENTION

All major changes in respect to the Rules for Technical supervision of sea-going ships, Part 22 – Pollution Prevention, edition July 2025, throughout the text are shaded (if any).

The grammar and print errors, have been corrected throughout the text of the Rules and are not subject to above indication of changes.

The subject Rules include the requirements of the following international organisations:

International Maritime Organisation (IMO)

Conventions: International Convention for the Prevention of Pollution from Ships 1973, as modified by the Protocol of 1978 relating thereto (MARPOL 73/78) and all subsequent amendments up to and including the 2024 amendments (MEPC.385(81))

Protocol of 1997 to amend the International Convention for the Prevention of Pollution from Ships, 1973, as modified by the Protocol of 1978 relating thereto

International Convention on the Control of Harmful Anti-fouling Systems on Ships, 2001, and up to including MEPC.331(76) amendments

International Convention for the Control and Management of Ships' Ballast Water and Sediments, 2004, and up to including MEPC.383(81) amendments

Resolutions: A.446(XI), A.495(XII), A.497(XII), A.673(16), A.851(20), A.897(21), MEPC.5(XIII), MEPC.54(32), MEPC.58(33), MEPC.59(33), MEPC.71(38), MEPC.85(44), MEPC.86(44), MEPC.92(45), MEPC.102(48), MEPC.103(49), MEPC.107(49), MEPC.108(49), MEPC.110(49), MEPC.128(53), MEPC.138(53), MEPC.148(54), MEPC.158(55), MEPC.159(55), MEPC.182(59), MEPC.185(59), MEPC.220(63), MEPC.227(64), MEPC.230(65), MEPC.232(65), MEPC.240(65), MEPC.243(66), MEPC.244(66), MEPC.255(67), MEPC.262(68), MEPC.264(68), MEPC.272(69), MEPC.279(70), MEPC.284(70), MEPC.285(70), MEPC.311(73), MEPC.312(74), MEPC.324(75), MEPC.325(75), MEPC.328(76), MEPC.329(76), MEPC.330(76), MEPC.331(76), MEPC.335(76), MEPC.338(76), MEPC.340(77), MEPC.344(78), MEPC.346(78) to MEPC.358(78), MEPC.364(79), MEPC.365(79), MEPC.368(79), MEPC.370(80) to MEPC.375(80), MEPC.379(80), MEPC.386(81) to MEPC.390(81), MEPC.392(82), MEPC.395(82), **MEPC.399(83), MEPC.400(83), MEPC.401(83), MEPC.403(83), MEPC.405(83)**

Codes: **Technical Code on Control of Emission of Nitrogen Oxides from Marine Diesel Engines (NOx Technical Code 2008), MEPC.177(58) and up to including MEPC.397(83) and MEPC.398(83) amendments**
Code for Approval of Ballast Water Management Systems (BWMS Code), MEPC.300(72)
Connection to IBC, BCH, IMDG, NO_x and Polar Codes

Circulars: MEPC.1/Circ.642, MEPC.1/Circ.676, MEPC.1/Circ.680, MEPC.1/Circ.864, Rev.1, MEPC.1/Circ.889, MEPC.1/Circ.892, MEPC.1/Circ.913, MSC/Circ.585, BWM.2/Circ.43, Rev.2, BWM.2/Circ.70, Rev.1, BWM.2/Circ.80, Rev.1, BWM.2/Circ.82

International Association of Classification Societies (IACS)

Unified Interpretations (UI): MPC2 (Rev. 1, 2015), MPC12 (Rev. 2, 2014; Corr. 1, 2014), MPC14 (Rev. 1, 2014), MPC20 (Rev. 1, 2014), MPC29 (Rev. 2, 2023), MPC88 (Rev. 1, 2015), MPC103 (2013), MPC106 (2015), MPC112 (Rev.1, 2019), MPC115 (Rev.1, corr.1, May 2020), MPC116 (Rev.1, 2019), MPC125 (rev. 1, May 2023), MPC128 (2016), MPC131 (2024)

Procedural Requirements (PR): No. 38 (Rev. 5, Oct 2024)

Recommendations (Rec.): No. 180 (Rev. 1, Nov 2024)

European Union – European Parliament and Council

Regulations: EU Regulation (EC) No.782/2003 of the European Parliament and of the Council of 14th April 2003 on the prohibition of organotin compounds on ships
EU Regulation (EC) No 1005/2009 of the European parliament and of the Council of 16th September 2009 on substances that deplete the ozone layer

Directives: Council Directive 2016/802/EU of 11th May 2016 relating to a reduction in the sulphur content of certain liquid fuels

Contents:		Page
1	GENERAL.....	1
1.1	GENERAL REQUIREMENTS.....	1
2	PREVENTION OF POLLUTION BY OIL.....	3
2.1	GENERAL REQUIREMENTS.....	3
2.2	OIL TANKERS.....	8
2.3	OIL FILTERING EQUIPMENT.....	15
2.4	OIL DISCHARGE MONITORING AND CONTROL SYSTEMS.....	16
2.5	OILY-WATER TRANSFER AND DISCHARGE SYSTEM OF PIPING.....	23
2.6	TANKS FOR OIL RESIDUES (SLUDGE) AND OILY-WATER(BILGE) OF A MACHINERY SPACE.....	25
2.7	SPECIAL REQUIREMENTS FOR FIXED OR FLOATING PLATFORMS.....	28
2.8	SHIPBOARD OIL POLLUTION EMERGENCY PLAN.....	29
2.9	STS OPERATIONS PLAN.....	29
3	PREVENTION OF POLLUTION BY NOXIOUS LIQUID SUBSTANCES IN BULK.....	30
3.1	GENERAL.....	30
3.2	CHEMICAL TANKER CONSTRUCTION.....	33
3.3	EQUIPMENT FOR PREVENTION OF POLLUTION.....	33
3.4	SHIPBOARD MARINE POLLUTION EMERGENCY PLAN FOR NOXIOUS LIQUID SUBSTANCES.....	38
4	PREVENTION OF POLLUTION BY HARMFUL SUBSTANCES CARRIED BY SEA IN PACKAGED FORM.....	39
5	PREVENTION OF POLLUTION BY SEWAGE.....	40
5.1	GENERAL.....	40
5.2	ARRANGEMENT AND EQUIPMENT FOR TREATMENT AND DISCHARGE OF SEWAGE.....	41
6	PREVENTION OF POLLUTION BY GARBAGE.....	45
6.1	GENERAL.....	45
6.2	ARRANGEMENT AND EQUIPMENT FOR COLLECTION AND PROCESSING OF GARBAGE AND INCINERATION OF WASTES.....	45
6.3	PLACARDS, GARBAGE MANAGEMENT PLANS, GARBAGE RECORD BOOK.....	48
7	PREVENTION OF AIR POLLUTION.....	49
7.1	GENERAL.....	49
7.2	SURVEY, CERTIFICATION AND MEANS OF CONTROL.....	51
7.3	REQUIREMENTS FOR CONTROL OF EMISSIONS FROM SHIPS.....	53
7.4	REQUIREMENTS OF NO _x TECHNICAL CODE 2008.....	59
8	CONTROL OF HARMFUL ANTI-FOULING SYSTEMS ON SHIPS.....	74
8.1	GENERAL REQUIREMENTS.....	74
8.2	HARMFUL ANTI-FOULING SYSTEMS ON SHIPS AND CONTROL MEASURES.....	74
8.3	SURVEY AND CERTIFICATION OF ANTI-FOULING SYSTEMS ON SHIPS.....	75
9	ENERGY EFFICIENCY FOR SHIPS.....	78
9.1	GENERAL.....	78
9.2	REQUIREMENTS ON ENERGY EFFICIENCY FOR SHIPS.....	81
9.3	COLLECTION AND REPORTING OF SHIP FUEL OIL CONSUMPTION DATA.....	86
9.4	OPERATIONAL CARBON INTENSITY.....	87
10	CONTROL AND MANAGEMENT OF SHIPS' BALLAST WATER AND SEDIMENTS.....	88
10.1	GENERAL REQUIREMENTS.....	88
10.2	MANAGEMENT AND CONTROL OF BALLAST WATER AND SEDIMENTS.....	90
10.3	BALLAST WATER MANAGEMENT SYSTEMS.....	94

1 GENERAL

1.1 GENERAL REQUIREMENTS

1.1.1 Application

1.1.1.1 *Rules for the technical supervision of sea-going ships, Part 22 - Prevention of Pollution* (hereinafter referred as: the Rules) of Croatian Register of Shipping (hereinafter referred to as: the *Register*), shall apply to new ships, namely:

- .1 Passenger ships, tankers intended for carriage of oil and other noxious or harmful substances and tugs, irrespective of the main engine of shaft output and gross tonnage;
- .2 Self-propelled ships, which are not specified in 1.1.1.1, with the main engine of the shaft output of 110 kW and over, if uses oil as a fuel;
- .3 Self-propelled ships, which are not specified in 1.1.1.1 and 1.1.1.2, of gross tonnage 50 tons and over.

1.1.1.2 The present Rules may apply to ships not specified in 1.1.1, if the *Register* deems necessary, or approves.

1.1.1.3 The present Rules shall apply to existing ships too, within extent specified in Sections 2, 3, 4, 5, 6, 7, 8, 9 and 10 of the present Rules.

1.1.1.4 Possibilities for violation from the requirements, specified in 1.1.1 have been specified in the relevant Sections of the present Rules.

1.1.1.5 When authorized by the Flag State Administration the *Register* will act on its behalf within limits of such authorization. When certifying systems and items of equipment falling under the scope of the Rules the *Register* will take into account any specific or additional requirements of the Flag State Administration.

Therefore, the Rules, or any part of it, should be applied only if the Flag State Administration has not provided the *Register* with written instruction to apply different interpretation. In the case of discrepancy between such national requirements and those of the *Rules* the former shall take precedence.

1.1.1.6 All ships operating in polar waters shall comply with the environment related provisions of the introduction and with part II-A of the Polar Code, in addition to any other applicable requirements of these Rules. In applying part II-A, consideration should be given to the additional guidance in part II-B of the Polar Code.

1.1.2 Definitions

For the purposes of the present *Rules* the following definitions apply:

1.1.2.1 Rules – means *Rules for technical supervision of sea-going ships, Part 22 - the Prevention of Pollution*, including ten Sections as follows:

Section 1 – General

- Section 2 – Prevention of Pollution by Oil
- Section 3 – Prevention of Pollution by Noxious Liquid Substances in Bulk
- Section 4 – Prevention of Pollution by Harmful Substances Carried by Sea in Packed Form
- Section 5 – Prevention of Pollution by Sewage
- Section 6 – Prevention of Pollution by Garbage
- Section 7 – Prevention of Air Pollution
- Section 8 – Control of harmful anti-fouling systems on ships
- Section 9 – Energy efficiency for ships
- Section 10 – Control and management of ships' ballast water and sediments.

1.1.2.2 Harmful substance – means any substance which, if introduced into the sea, is liable to create hazards to human health, to harm living resources and marine life, to damage amenities or to interfere with other legitimate uses of the sea, and includes any substance subject to control by Convention MARPOL 73/78.

1.1.2.3 Discharge – in relation to harmful substances or effluents containing such substances, means any release however caused from a ship and includes any escape, disposal, spilling, leaking, pumping, emitting or emptying;

Discharge does not include:

- .1 dumping within the meaning of the Convention on the Prevention of Marine Pollution by Dumping of Wastes and Other Matter, done at London on 13th November 1972; or
- .2 release of harmful substances directly arising from the exploration, exploitation and associated offshore processing of sea-bed mineral resources; or
- .3 release of harmful substances for purposes of legitimate scientific research into pollution abatement or control.

1.1.2.4 Ship – means a vessel of any type whatsoever operating in the marine environment and includes hydrofoil boats, air-cushion vehicles, submersibles, floating craft and fixed or floating platforms.

1.1.2.5 Administration – means the Government of the State under whose authority the ship is operating.

With respect to a ship entitled to fly a flag of any State, the Administration is the Government of that State (i.e. *Flag State Administration*).

With respect to fixed or floating platforms engaged in exploration and exploitation of the sea-bed and subsoil thereof adjacent to the coast over which the coastal State exercises sovereign rights for the purposes of exploration and exploitation of their natural resources, the Administration is the Government of the coastal State concerned (i.e. *Coastal State Administration*).

1.1.2.6 Incident – means an event involving the actual or probable discharge into the sea of a harmful substance, or effluents containing such a substance.

1.1.2.7 Organisation – means the International Maritime Organisation (IMO).

1.1.2.8 MARPOL 73/78 – International Convention for the Prevention of Pollution from Ships, 1973, as modified by

the Protocol of 1978 relating thereto and Amendments contained (included) in MEPC Resolutions up-to-date. Hereinafter referred as *MARPOL 73/78* or *Convention*.

1.1.2.9 MEPC – Marine Environment Protection committee.

1.1.2.10 Polar Code – means the International Code for ships operating in polar waters.

1.1.2.11 Category A ship – means a ship designed for operation in polar waters in at least medium first-year ice, which may include old ice inclusions..

1.1.2.12 Category B ship – means a ship not included in category A, designed for operation in polar waters in at least thin first-year ice, which may include old ice inclusions.

1.1.2.13 Category C ship – means a ship designed to operate in open water or in ice conditions less severe than those included in categories A and B.

1.1.2.14 Arctic waters – means those waters determined in MARPOL 73/78, Annex I, Regulation 46.

1.1.2.15 Polar waters – means Arctic waters and/or the Antarctic area.

1.1.2.16 Electronic Record Book – means a device or system, approved by the Administration, used to electronically record the required entries for discharges, transfers and other operations as required under these Rules in lieu of a hard copy record book.

2 PREVENTION OF POLLUTION BY OIL

2.1 GENERAL REQUIREMENTS

2.1.1 Application

2.1.1.1 The present Section applies to performance, equipment, installations and systems provided for prevention of sea pollution by oil.

2.1.1.2 Unless expressly provided otherwise, the requirements of this Section apply to:

- .1 all tankers, irrespective of gross tonnage, and
- .2 all ships which are not tankers of gross tonnage 50 tons and over and ships with the main engine shaft output of 110 kW and over, if uses oil as a fuel.

2.1.1.3 Intentionally blank.

2.1.2 Definitions

The explanation of terms and expressions, used in all Sections, is specified in Section 1 - General.

The following terms and expressions are applied in the present Section:

2.1.2.1 Oil – means petroleum in any form including crude oil, fuel oil, sludge, oil refuse and refined products (other than petrochemical which are subject to the provisions of Section 3).

2.1.2.2 Crude oil – means any liquid hydrocarbon mixture occurring naturally in the earth whether or not treated to render it suitable for transportation and includes:

- .1 crude oil from which certain distillate fractions may have been removed; and
- .2 crude oil to which certain distillate fractions may have been added.

2.1.2.3 Oily mixture – means a mixture with any oil content.

2.1.2.4 Oil fuel – means any oil used as fuel in connection with the propulsion and auxiliary machinery of the ship in which such oil is carried.

2.1.2.5 Oil tanker – means a ship constructed or adapted primarily to carry oil in bulk in its cargo spaces and includes combination carriers and any *chemical tanker* as defined in 3.1.2.1 when it is carrying a cargo or part cargo of oil in bulk.

2.1.2.6 Crude oil tanker – means an oil tanker engaged in the trade of carrying crude oil.

2.1.2.7 Product carrier – means an oil tanker engaged in the trade of carrying oil other than crude oil.

2.1.2.8 Combination carrier – means a ship designed to carry either oil or solid cargoes in bulk.

2.1.2.9 Ship delivered after 31st December 1979 – means a ship:

- .1 for which the building contract is placed after 31st December 1975; or
- .2 in the absence of a building contract, the keel of which is laid or which is at a similar stage of construction after 30th June 1976; or
- .3 the delivery of which is after 31st December 1979; or
- .4 which has undergone a major conversion:
 - .1 for which the contract is placed after 31st December 1975; or
 - .2 in the absence of a contract, the construction work of which is begun after 30th June 1976; or
 - .3 which is completed after 31st December 1979.

2.1.2.10 Ship delivered on or after 1st August 2010 – means a ship:

- .1 for which the building contract is placed on or after 1st August 2007; or
- .2 in the absence of a building contract, the keel of which is laid or which is at a similar stage of construction on or after 1st February 2008; or
- .3 the delivery of which is on or after 1st August 2010; or
- .4 which has undergone a major conversion:
 - .1 for which the contract is placed on or after 1st August 2007; or
 - .2 in the absence of a contract, the construction work of which is begun on or after 1st February 2008; or
 - .3 which is completed on or after 1st August 2010.

2.1.2.11 Oil tanker delivered after 1st June 1982 – means an oil tanker:

- .1 for which the building contract is placed after 1st June 1979; or
- .2 in the absence of a building contract, the keel of which is laid or which is at a similar stage of construction after 1st January 1980; or
- .3 the delivery of which is after 1st June 1982; or
- .4 which has undergone a major conversion:
 - .1 for which the contract is placed after 1st June 1979; or
 - .2 in the absence of a contract, the construction work of which is begun after 1st January 1980; or
 - .3 which is completed after 1st June 1982.

2.1.2.12 Oil tanker delivered on or after 6th July 1996 – means an oil tanker:

- .1 for which the building contract is placed on or after 6th July 1993; or
- .2 in the absence of a building contract, the keel of which is laid or which is at a similar stage of construction on or after 6th January 1994; or

- .3 the delivery of which is on or after 6th July 1996; or
- .4 which has undergone a major conversion:
 - .1 for which the contract is placed on or after 6th July 1993; or
 - .2 in the absence of a contract, the construction work of which is begun on or after 6th January 1994; or
 - .3 which is completed on or after 6th July 1996.

2.1.2.13 Oil tanker delivered on or after 1st February 2002 – means an oil tanker:

- .1 for which the building contract is placed on or after 1st February 1999; or
- .2 in the absence of a building contract, the keel of which is laid or which is at a similar stage of construction on or after 1st August 1999; or
- .3 the delivery of which is on or after 1st February 2002; or
- .4 which has undergone a major conversion:
 - .1 for which the contract is placed on or after 1st February 1999; or
 - .2 in the absence of a contract, the construction work of which is begun on or after 1st August 1999; or
 - .3 which is completed on or after 1st February 2002.

2.1.2.14 Oil tanker delivered on or after 1st January 2010 – means an oil tanker:

- .1 for which the building contract is placed on or after 1st January 2007; or
- .2 in the absence of a building contract, the keel of which is laid or which is at a similar stage of construction on or after 1st July 2007; or
- .3 the delivery of which is on or after 1st January 2010; or
- .4 which has undergone a major conversion:
 - .1 for which the contract is placed on or after 1st January 2007; or
 - .2 in the absence of a contract, the construction work of which is begun on or after 1st July 2007; or
 - .3 which is completed on or after 1st January 2010.

2.1.2.15 Major conversion – means a conversion of an existing ship:

- .1 which substantially alters the dimension or carrying capacity of the ship; or
- .2 which changes the type of the ship; or
- .3 the intent of which in the opinion of the *Register* is substantially to prolong its life; or
- .4 which otherwise so alters the ship that, if it were a new ship, it would become subject to relevant provisions of the present Rules not applicable to it as an existing ship.

Conversion of an oil tanker of 20 000 tons deadweight and above delivered on or before 1st June 1982 to meet the requirements for segregated ballast tanks and for protective

location of segregated ballast tanks shall not be deemed to constitute a major conversion.

Conversion of an oil tanker delivered before 6th July 1996 to meet the requirements for double hull and double bottom shall not be deemed to constitute a major conversion.

2.1.2.16 Constructed – means a ship the keel of which is laid or which is at a similar stage of construction.

2.1.2.17 Tank – means an enclosed space which is formed by the permanent structure of a ship and which is designed for the carriage of liquid in bulk.

2.1.2.18 Wing tank – means any tank adjacent to the side shell plating.

2.1.2.19 Centre tank – means any tank inboard of a longitudinal bulkhead.

2.1.2.20 Slop tank – means a tank specifically designated for the collection of tank draining, tank washings and other oily mixtures.

2.1.2.21 Clean ballast – means the ballast in a tank which since oil was last carried therein, has been so cleaned that effluent therefrom if it were discharged from a ship which is stationary into clean calm water on a clear day would not produce visible traces of oil on the surface of the water or on adjoining shorelines or cause a sludge or emulsion to be deposited beneath the surface of the water or upon adjoining shorelines. If the ballast is discharged through an oil discharge monitoring and control system approved by the *Register*, evidence based on such a system to the effect that the oil content of the effluent did not exceed 15 parts per million shall be determinative that the ballast was clean, notwithstanding the presence of visible traces.

2.1.2.22 Segregated ballast – means the ballast water introduced into a tank which is completely separated from the cargo oil and oil fuel system and which is permanently allocated to the carriage of ballast or to the carriage of ballast or cargoes other than oil or noxious liquid substances as variously defined in the Section 3.

2.1.2.23 Arrival ballast – means clean ballast, see 2.1.2.21.

2.1.2.24 Departure ballast – means ballast other than arrival ballast.

2.1.2.25 Water rinse – means the water washing process carried out in connection with tank cleaning after crude oil washing and is not intended to be construed as limiting the amount of water needed in the process.

2.1.2.26 Length *L* – means 96% of the total length on a waterline at 85% of the least moulded depth measured from the top of the keel, or the length from the fore side of the stem to the axis of the rudder stock on that waterline, if that be greater. In ships designed with a rake of keel the waterline on which this length is measured shall be parallel to the designed waterline. The length *L* shall be measured in metres.

2.1.2.27 Forward and after perpendiculars – shall be taken at the forward and after ends of the length *L*. The forward perpendicular shall coincide with the fore side of the stem on the waterline on which the length is measured.

2.1.2.28 Amidships – is at the middle of the length *L*.

2.1.2.29 Breadth *B* – means the maximum breadth of the ship, measured amidships to the moulded line of the frame in a ship with a metal shell and to the outer surface of the hull in a ship with a shell of any other material. The breadth *B* shall be measured in metres.

2.1.2.30 Dead-weight (DW) - means the difference in tonnes between the displacement of a ship in water of a density of 1,025 t/m³ at the load waterline corresponding to the assigned summer freeboard and the lightweight of the ship.

2.1.2.31 Lightweight – means the displacement of a ship in metric tons without cargo, fuel, lubricating oil, ballast water, fresh water and feed water in tanks, consumable stores, and passengers and crew and their effects, and including the weight of mediums onboard for the fixed fire-fighting systems.

2.1.2.32 Volumes and areas – in a ship shall be calculated in all cases to moulded lines.

2.1.2.33 Special areas – for the purpose of regulations in this Section, areas determined in MARPOL 73/78, Annex I, Regulation 1(11).

2.1.2.34 Nearest land – the term *from the nearest land* means from the baseline from which the territorial sea of the territory in question is established in accordance with international law.

2.1.2.35 15 ppm bilge separator – may include any combinations of a separator, filter, coalescer or other means, and also a single unit designed to produce an effluent with oil content not exceeding 15 ppm.

2.1.2.36 15 ppm bilge alarm – the alarm arrangements specified in regulation 2.4.2 are referred to in this Section as a 15 ppm Bilge Alarm.

2.1.2.37 Automatic stopping device – is a device used, where applicable, to automatically stop any discharge overboard of oily mixture when the oil content of the effluent exceeds 15 ppm.

2.1.2.38 Parts per million (ppm) – means parts of oil per million parts of water by volume.

2.1.2.39 Oil discharge monitoring and control system – is a system which monitors the discharge into the sea of oily ballast or other oil-contaminated water from the cargo tank areas and comprises the items specified in paragraph 2.4.3.2-.3.

2.1.2.40 Control section – of a monitoring system is a unit composed of the items specified in paragraph 2.4.3.2-.3 to 2.4.3.2-.8.

2.1.2.41 Overboard discharge control – is a device which automatically initiates the sequence to stop the overboard discharge of the effluent in alarm conditions and prevents the discharge throughout the period the alarm condition prevails. The device may be arranged to close the overboard valves or to stop the relevant pumps, as appropriate.

2.1.2.42 Starting interlock – is a facility which prevents the initiation of the opening of the discharge valve or the operation of other equivalent arrangements before the monitoring system is fully operational when use of the monitoring system is required by the Convention.

2.1.2.43 Control unit – is a device which receives automatic signals of:

- .1 oil content of the effluent ppm;
- .2 flow rate of discharge m³/hour;
- .3 ship's speed in knots;
- .4 ship's position - latitude and longitude;
- .5 date and time (GMT); and
- .6 status of the overboard discharge control.

The unit shall make automatic recordings of data as specified in paragraph 2.4.3.9-2.

2.1.2.44 Instantaneous rate of discharge of oil content – means the rate of discharge of oil in litres per hour at any instant divided by the speed of the ship in knots at the same instant.

2.1.2.45 Unmanned non-self-propelled (UNSP) barge – means a barge that:

- .1 is not propelled by mechanical means;
- .2 carries no oil (as defined in item 2.1.2.1 of this Section);
- .3 has no machinery fitted that may use oil or generate oil residue (sludge);
- .4 has no oil fuel tank, lubricating oil tank, oily bilge water holding tank and oil residue (sludge) tank; and
- .5 has neither persons nor living animals on board.

2.1.3 Scope of supervision

2.1.3.1 Intentionally blank.

2.1.3.2 Supervision during construction shall cover:

- .1 Oil filtering equipment;
- .2 Oil-water interface detectors;
- .3 Crude oil washing system;
- .4 Oil discharge monitoring and control systems;
- .5 Systems for transfer of oil residues and oily water to reception facilities or other ships;
- .6 Systems for transfer, retaining and/or discharge of oily water overboard.

2.1.3.3 Technical documentation which shall be submitted to *Register* for approval in addition to those referred to in 2.1.3.1, as appropriate:

- .1 technical description, method of work, instructions for operation and maintenance (for information);
- .2 general and functional scheme of equipment and system;
- .3 assembly drawing of the equipment or system with cross-sections, main scantlings and list of parts and materials;
- .4 drawings of essential parts of the equipment or system with indicated material properties as well as working and test pressure;
- .5 scheme for monitoring and control system;
- .6 basic electric schemes;
- .7 program for individual and type testing;
- .8 list of spare parts.

2.1.3.4 The documentation of a monitoring system to be submitted to the *Register* for approval should include at least all the following:

- .1 a description of the monitoring system. The description should include a diagrammatic drawing of the pumping and piping arrangements, identifying the operational outlets for dirty ballast and oil-contaminated water from the cargo tank area and compatible with the operational requirements set out in the oil tanker's cargo and ballast handling manuals. Special considerations may have to be given to installations in oil tankers which have unusual pumping and piping arrangements;
- .2 equipment manuals, supplied by manufacturers, which should contain details of the major components of the monitoring system;
- .3 an operations and technical manual for the complete monitoring system which is proposed to be installed in the oil tanker. This manual should cover the arrangements and operation of the system as a whole and should specifically describe parts of the system which are not covered by the manufacturer's equipment manuals;
- .4 the operations section of the manual should include normal operational procedures and procedures for the discharge of oily water in the event of malfunction of the equipment;
- .5 the technical section of the manual should include adequate information (description and diagrammatic drawings of the pumping and piping arrangements of the monitoring system and electrical/electronic wiring diagrams) to enable fault finding and should include instructions for keeping a maintenance record;
- .6 a technical installation specification defining, *inter alia*, the location and mounting of components, arrangements for maintaining the integrity of the boundary between safe and hazardous spaces and the arrangement of the sample piping, including calculation of the sample response time referred to in 2.4.3.3-.6. The installation should comply with manufacturers specific installation criteria;
- .7 a copy of the certificate of type approval for the oil content meter and technical documentation relevant to other main components of the monitoring system; and
- .8 a recommended test and checkout procedure specific to the monitoring system installed. This procedure should specify all the checks to be carried out in a functional test by the installation contractor and should provide guidance for the surveyor when carrying out the on-board survey of the monitoring system and confirming the installation reflects the manufacturers specific installation criteria.

2.1.4 Workshop testing

2.1.4.1 Equipment, installations and accessories after being assembled shall be tested on the test bench in compliance with the program approved by the *Register*. In particular cases *Register* may replace testing on the test bench with testing onboard ship.

2.1.4.2 Each oil content meter and each control section of a monitoring system should be subjected to a functional test on a suitable test bench prior to delivery. The detailed programme for a functional test of such equipment should be developed by the manufacturer, taking into account the features and functions of the specific design of equipment. A completed workshop certificate including the delivery test protocol should be supplied with each unit delivered.

2.1.4.3 A functional test conducted on an oil content meter should include at least all the following operations:

- .1 check flow rate, pressure drop, or an equivalent parameter as appropriate;
- .2 check all alarm functions built into the meter;
- .3 check all switching functions interconnecting with other parts of the system; and
- .4 check correct reading at several ppm values on all measurement scales when operated on an oil appropriate for the application of the meter or by an equivalent method.

2.1.4.4 A functional check conducted on a control section of a monitoring system should include at least all the following operations:

- .1 check all alarm functions;
- .2 check correct function of the signal processor and the recording equipment when simulated input signals of ppm, flow rate, and speed are varied;
- .3 check that the alarm is activated when the input signals are varied so that the discharge limits contained in regulation 2.4.3.7-.2.1 and 2.4.3.7-.2.2 are exceeded;
- .4 check that a signal is given to the overboard discharge control when alarm conditions are reached; and
- .5 check that the alarm is activated when each one of the input signals is varied to exceed the capacity of the system.

2.1.5 On-board functional testing

2.1.5.1 The functional test of the monitoring system referred to in 2.1.3.4-.8 should include at least all the following tests when the monitoring system is operating on water:

- .1 verify correct running of pumps, absence of leakage in the sample pumping and piping system, correct functioning of remote controlled sampling valves, etc.;
- .2 verify by checking flow rates or pressure drops, as appropriate, that the system operates under correct flow conditions. This test should be repeated separately for each sampling point;

- .3 verify that alarms function correctly when a malfunction occurs external to the monitoring system, such as no sample flow, no flow meter signal, power failure, etc.;
- .4 vary the simulated input signals manually while the monitoring system is operating on water and check the recordings for correct values and timing. Vary the simulated manual input signals until alarm conditions are obtained, and verify proper recordings. Ascertain that the overboard discharge control is activating and verify that the action is being recorded;
- .5 verify that normal operating condition can be reset when the value of the instantaneous rate of discharge is reduced below 30 litres per nautical mile;
- .6 activate the manual override control and verify that a recording is made and that the overboard discharge control can be operated;
- .7 turn off the system and verify that the overboard discharge valve closes automatically or the relevant pumps are stopped and the overboard discharge control is inoperative;
- .8 start up the system and check the zero and gain setting for the oil content meter in accordance with the manufacturer's operations and technical manual; and
- .9 check the accuracy of the flow meter(s), for example by pumping water in a loop where the flow rate may be calculated from the level change in a tank. The check should be made at a flow rate of about 50% of the rated flow of the flow meter.

2.1.5.2 To confirm the effectiveness of the crude oil washing system and stripping system, the crude oil washing operation should be witnessed to the satisfaction of the *Register*.

- .1 For ships that comply with MARPOL 73/78, Annex I, regulation 19(3), the crude oil washing operations are to be carried out using the approved crude oil washing equipment and as specified in the approved Operations and Equipment Manual. For at least one tank of a group of tanks of similar configuration, the *Register* should:
 - .1 confirm the operation of the stripping system by observing the monitoring devices and monitoring the oil level (by dipping or other means) during bottom washing;
 - .2 monitor the proper operation of the washing machines with particular reference to supply pressure, cycle times and machine function.

On completion of washing and final draining, the tanks are to be hand dipped, as close as practical to the forward end, centre and aft end in each tank and a record of these dips should be made in the Operations and Equipment Manual. The *Register* may require an internal

examination as described in 2.1.5.2-.2.1, or by an alternative method (e.g. video survey or other new technology) acceptable to the *Register*, if deemed necessary.

- .2 For ships other than those complying with MARPOL 73/78, Annex I, regulation 19(3), where fitted with cargo tanks intended to be used in certain circumstances as ballast tanks, the following requirements apply in addition to those specified in 2.1.5.2-.1:
 - .1 To ensure that the tank is essentially free of clingage and deposits, the *Register* may require that the cleanliness of the tank be confirmed by a visual inspection made by entering the tanks after a crude oil washing but prior to any water rinse which may be specified in the Operations and Equipment Manual. If the tanks cannot be gas-freed for safe entry of the surveyor, an internal examination should not be conducted and the stripping test specified in 2.1.5.2-.2.2 will be acceptable. In this case, the bottom of the tank to be inspected may be flushed with water and stripped in order to remove any wedge of liquid crude oil remaining on the tank bottom before gas-freeing for entry. If the flushing procedure is adopted, a similar but unflushed tank must be used for the test specified in 2.1.5.2-.2.2.
 - .2 To verify the effectiveness of the stripping and drainage arrangements, a measurement should be made of the amount of oil floating on top of the departure ballast. The ratio of the volume of oil on top of the total departure ballast water to the volume of tanks that contain this water should not exceed 0,00085. This test should be carried out after crude oil washing and stripping in a tank similar in all relevant respects to the tank examined in accordance with 2.1.5.2-.2.1, which has not been subjected to a water rinse or to the intervening water flushing permissible in 2.1.5.2-.2.1.
 - .3 To verify the design, installation and operation of the system, the arrival ballast, after a typical ballast voyage before which the arrival ballast tanks have been crude oil washed and during which the tanks have been water rinsed in accordance with the programme set out in the Operations and Equipment Manual, should be totally discharged to the loading port harbour through an oil discharged monitoring and control (ODM) system approved by the *Register*. The oil content of the effluent in this test should not exceed 15 ppm. Alternatively, the option of

taking ballast water samples to be analysed in a shore-based laboratory is also acceptable.

This paragraph is not applicable to crude oil tankers of 20 000 tons deadweight and above delivered after 1st June 1982.

- .3 Where the *Register* is satisfied that ships are similar in all relevant respects, the requirements of 2.1.5.2-.1 or 2.1.5.2-.2 need only be applied to one such ship. Furthermore, where a ship has a series of tanks that are similar in all relevant respects then, for that series of tanks, the requirements of 2.1.5.2-.1 need only be applied to one tank of that series.

2.1.6 General requirements

2.1.6.1 Steel, forged, cast and welded parts as well as those of cast iron shall be manufactured and tested in compliance with the requirements of the *Rules for the classification of ships, Part 25 - Metallic materials* and *Part 26 - Welding*.

2.1.6.2 Parts of equipment and installations which come in contact with the substances causing corrosion shall be of the corrosion-resistant materials or shall be with anti-corrosive protection.

2.1.6.3 Automatic and remote control systems, measurement, monitoring and indication systems shall comply with the requirements of the *Rules for the classification of ships, Part 13 - Automation*.

2.1.6.4 Pipelines, pipes and fittings of the equipment shall comply with the requirements of the *Rules for the classification of ships, Part 8 - Piping*.

2.1.6.5 Electrical installation of the systems and equipment shall comply with the requirements of the *Rules for the classification of ships, Part 12 - Electrical installation*.

2.1.6.6 Oily-water transfer pumps and washing systems shall comply with the requirements of the *Rules for the classification of ships, Part 9 - Machines*.

2.1.6.7 Casings of separators, filters and other elements of the oily-water filtering equipment which are operating under pressure, shall comply with the requirements of the *Rules for the classification of ships, Part 10 - Boilers, Heat Exchangers and Pressure vessels*.

2.1.7 Segregation of oil and water ballast and carriage of oil in forepeak tanks

2.1.7.1 In ships delivered after 31st December 1979 of 4000 gross tonnage and above other than oil tankers, and in oil tankers delivered after 31st December 1979 of 150 gross tonnage and above, no ballast water shall be carried in any oil fuel tank.

2.1.7.2 For ships other than oil tankers fitted with cargo spaces which are constructed and utilised to carry oil in bulk of an aggregate capacity of 200 m³ or more, the requirements of 2.1.7.1 for oil tankers shall also apply.

2.1.7.3 In a ship of 400 gross tonnage and above, for which the building contract is placed after 1st January 1982 or, in the absence of a building contract, the keel of which is laid or which is at a similar stage of construction after 1st July 1982, oil shall not be carried in a forepeak tank or a tank forward of the collision bulkhead.

2.1.8 Oil record book

Every oil tanker of 150 gross tonnage and above and every ship of 400 gross tonnage and above other than an oil tanker shall be provided with an Oil Record Book Part I (machinery space operations).

Every oil tanker of 150 gross tonnage and above shall be provided with an Oil Record Book Part II (cargo/ballast operations).

The Oil Record Book, Part I / Part II whether as a part of the ship's official logbook, as an electronic record book which shall be approved by the Administration taking into account the Guidelines in Resolution MEPC.312(74), or otherwise, shall be in the form specified in appendix III to MARPOL 73/78, Annex I.

2.2 OIL TANKERS

2.2.1 Crude oil washing system

2.2.1.1 General

- .1 Every crude oil tanker of 20 000 tons deadweight and above delivered after 1st June 1982 shall be fitted with a cargo tank cleaning system using crude oil washing.
- .2 The system shall fully comply with the requirements of IMO Res. A.446(XI) as amended by IMO Res. A.497(XII) and resolution A.897(21) within one year after the tanker was first engaged in the trade of carrying crude oil or by the end of the third voyage carrying crude oil suitable for crude oil washing, whichever occurs later (see 2.1.5.2).
- .3 Every oil tanker operating with crude oil washing system shall be provided with an Operations and Equipment Manual detailing the system and equipment and specifying operational procedures, to the satisfaction of the *Register*.
- .4 Every oil tanker fitted with a cargo tank cleaning system using crude oil washing shall be provided with an inert gas system, according to *Rules for the classification of ships, Part 17 - Fire protection*.

2.2.1.2 Piping

- .1 The crude oil washing pipes and all valves incorporated in the supply piping system shall be of steel or other equivalent material and shall be of adequate strength having regard to the pressure to which they

may be subjected, and shall be properly jointed and supported. Piping is to comply with the requirements of *Rules for the classification of ships, Part 8 - Piping*.

- .2 The crude oil washing system shall consist of permanent piping and shall be independent of the fire mains and of any system other than for tank washing. A sections of the ship's cargo system may be incorporated in the crude oil washing system provided that they meet the requirements applicable to crude oil piping.

- .3 Notwithstanding the requirements of 2.2.1.2-.2 in combination carriers the arrangement of crude oil washing system may allow:

- .1 The removal of the equipment, if necessary, when carrying cargoes other than crude oil, provided that, when reinstated, the system is as originally fitted and tested for oil tightness;
- .2 The use of flexible hose pipes to connect the crude oil washing system to tank washing machines if it is necessary to locate these machines in a cargo tank hatch cover. Such flexible hose pipes must be provided with flanged connections and be manufactured and tested in accordance with the *Rules for the classification of ships, Part 8 - Piping*. The length of these hoses shall be no greater than necessary to connect the tank washing machines to an adjacent point just outside the hatch coaming. These hoses shall be removed to suitably prepared and protected stowage when not in use and be pressure tested by an authority acceptable to the *Register* at intervals of not more than two and a half years.

- .4 Provision shall be made to prevent overpressure in the tank washing supply piping. Any relief device fitted to prevent overpressure shall discharge into the suction side of the supply pump. Alternative methods to the satisfaction of the *Register* may be accepted provided an equivalent degree of safety and environmental protection is provided.

One such alternative is that where the system is served only by centrifugal pumps so designed that the pressure derived cannot exceed that for which the piping is designed, a temperature sensing device located in the pump casing is required to stop the pump in the case of overheating.

- .5 Where hydrant valves are fitted for water washing purposes on tank washing lines, all such valves shall comply with 2.2.1.2-.1 and provision shall be made for such connections to be blanked off by blank flanges when washing lines may contain

crude oil. Alternatively, hydrant valves shall be isolated from the crude oil washing system by spade blanks.

- .6 All connections for pressure gauges or other instrumentation shall be provided with isolating valves adjacent to the lines unless the fitting is of the sealed type.

- .7 No part of the crude oil washing system shall enter the machinery spaces. Where the tank washing system is fitted with a steam heater for use when water washing, the heater must be effectively isolated during crude oil washing by double shut-off valves or by clearly identifiable blanks.

On oil tankers delivered after 1st June 1982 the steam heater referred to shall be located outside the machinery spaces. However, on an oil tanker delivered on or before 1st June 1982 with an existing steam heater located in the machinery spaces, no more additional isolation will be required other than that which isolates the crude oil washing system from the machinery spaces.

- .8 Where a combined crude oil-water washing supply piping is provided the piping shall be so designed that it can be drained so far as is practicable of crude oil, before water washing is commenced, into spaces designated in the *Operations and Equipment Manual*. These spaces may be the slop tank or other cargo spaces.

- .9 The piping system shall be of such diameter that the greatest number of tank cleaning machines required, as specified in 2.2.1.3-.8, can be operated simultaneously at the designed pressure and throughput. The arrangement of the piping shall be such that the required number of tank cleaning machines to each cargo compartment, can be operated simultaneously.

- .10 The piping system shall be tested to 1,5 times the working pressure after it has been installed on the ship.

- .11 The crude oil washing supply piping shall be anchored (firmly attached) to the ship's structure at appropriate locations, and means shall be provided to permit freedom of movement elsewhere to accommodate thermal expansion and flexing of the ship. The anchoring shall be such that any hydraulic shock can be absorbed without undue movement of the supply piping.

The anchors should normally be situated at the ends furthest from the entry of the crude oil supply to the supply piping. If tank washing machines are used to anchor the ends of branch pipes then special arrangements are necessary to anchor these sections when the machines are removed for any reason.

2.2.1.3 Tank washing machines

- .1 The tank washing machines for crude oil washing shall be permanently mounted and shall be of a design acceptable to the *Register*.
- .2 The performance characteristic of a tank washing machine is governed by nozzle diameter, working pressure and the movement pattern and timing. Each tank cleaning machine fitted shall have a characteristic such that the sections of the cargo tank covered by that machine will be effectively cleaned within the time specified in the Operations and Equipment Manual.
- .3 Tank washing machines shall be mounted in each cargo tank and the method of support shall be to the satisfaction of the *Register*. Where the tank washing machines are positioned well below the deck level to cater for protuberances in the tank, consideration may need to be given to additional support for the machines and their supply piping.
- .4 Each machine shall be capable of being isolated by means of stop valves in the supply line. If a deck mounted tank washing machine is removed for any reason, provision shall be made to blank off the oil supply line to the machine for the period the machine is removed. Similarly, provision shall be made to close the tank opening with a plate or equivalent means.

Where more than one submerged machine is connected to the same supply line a single isolating stop valve in the supply line may be acceptable provided the rotation of the submerged machines can be verified in accordance with 2.2.1.3-.11.1 or 2.2.1.3-.11.3.
- .5 Where the drive units for the tank cleaning machines are not integral with the tank cleaning machine, sufficient drive units shall be provided to ensure that no drive unit need be moved more than twice from its original position during cargo discharge to accomplish the washing programme as specified in the Operations and Equipment Manual. For crude oil tanker of 20 000 tons dead-weight and above, delivered after 1st June 1982 this is not applicable.
- .6 The number and location of the tank washing machines shall be to the satisfaction of *Register*.
- .7 The location of the machines is dependent upon the characteristics detailed in 2.2.1.3-.2 and upon the configuration of the internal structure of the tank.
- .8 The number and location of the machines in each cargo tank and oily mixture (slop)

tank shall be such that all horizontal and vertical areas are washed by direct impingement or effectively by deflection or splashing of the impinging jet. In assessing an acceptable degree of jet deflection and splashing, particular attention shall be paid to the washing of upward facing horizontal areas and the following parameters shall be used:

- .1 For horizontal areas of a tank bottom and the upper surfaces of a tank's stringers and other large primary structural members, the total area shielded from direct impingement by deck or bottom transverses, main girders, stringers or similar large primary structural members shall not exceed 10% of the total horizontal area of tank bottom, the upper surface of stringers, and other large primary structural members.
- .2 For vertical areas of the sides of a tank, the total area of the tank's sides shielded from direct impingement by deck or bottom transverses, main girders, stringers or similar large primary structural members shall not exceed 15% of the total area of the tank's sides.
- .3 For crude oil tankers delivered on or before 1 June 1982, the *Register* may permit the percentages required in 2.2.1.3-.8.1 and 2.2.1.3-.8.2 above to be exceeded for tanks having complicated internal structural members provided that the percentages calculated over all the cargo tanks do not exceed 10% for horizontal areas and 15% for vertical areas.

In some installations it may be necessary to consider the fitting of more than one type of tank washing machine in order to effect adequate coverage.

- .9 At the design stage the following minimum procedures shall be used to determine the area of the tank surface covered by direct impingement:
 - .1 Using suitable structural plans, lines are set out from the tips of each machine to those parts of the tank within the range of the jets.
 - .2 Where the configuration of the tanks is considered by the *Register* to be complicated, a pinpoint of light simulating the tip of the tank washing machine in a scale model of the tank shall be used.
 - .3 Shadow diagrams must be on drawings the scale of which must be at least:
 - .1 1:100 for tankers of less than 100.000 tons dead-weight
 - .2 1:200 for tankers of 100.000 tons dead-weight and above.

- .4 The drawings must provide at least a plan view, a profile view and an end elevation for each tank, or for tanks considered to be similar.
- .5 Sufficient detailed drawings of the vessel must be provided to check that all large primary structural members have been included.
- .6 Guidelines for the assessment of shadow diagrams are given in 4.2.9 of Appendix III to IMO resolution A.446(XI), as amended.
- .10 The design of the deck mounted tank washing machines shall be such that means are provided, external to the cargo tanks, which, when crude oil washing is in progress, would indicate the rotation and arc of the movement of the machine. Where the deck mounted machine is of the non-programmable, dual nozzle type, alternative methods to the satisfaction of the *Register* may be accepted provided an equivalent degree of verification is attained.
- .11 Where submerged machines are required, they should be non-programmable and, in order to comply with the requirements of 2.2.1.3-.8, it must be possible to verify their rotation by one of the following methods:
 - .1 By indicators external to the tank;
 - .2 By checking the characteristic sound pattern of the machine, in which case the operation of the machine shall be verified towards the end of each wash cycle.
Where two or more submerged machines are installed on the same supply line, valves shall be provided and arranged so that operation of each machine can be verified independently of the other machines on the same supply line;
 - .3 By gas freeing the tank and checking the operation of the machine with water during ballast voyages.

The method of verification shall be stated in the *Operations and Equipment Manual*.

- .12 Fixed washing machines shall comply with the following:
 - .1 Stresses in piping or deck supports which arise during washing operation or when immersed into liquid shall not exceed allowable stresses.
 - .2 Machines shall be made of steel or other material which does not initiate sparking due to friction more than steel.
 - .3 Machines shall be earthed through hull.

2.2.1.4 Pumps for crude oil washing system

- .1 The pumps supplying crude oil to the tank cleaning machines shall be either the cargo pumps or pumps specifically provided for the purpose.
- .2 The capacity of the pumps shall be sufficient to provide the necessary throughput at the required pressure for the maximum number of tank cleaning machines required to be operated simultaneously as specified in the Operations and Equipment Manual. In addition to the above requirement, the pumps shall, if an eductor system is fitted for tank stripping, be capable of supplying the eductor driving fluid to meet the requirements of 2.2.1.5-.2.
- .3 The capacity of the pumps shall be such that the requirements of 2.2.1.4-.2 can be met with any one pump inoperative. The pumping and piping arrangements shall be such that the crude oil washing system can be effectively operated with any one pump out of use.
- .4 The carriage of more than one grade of cargo shall not prevent crude oil washing of tanks.
- .5 To permit crude oil washing to be effectively carried out where the back pressure presented by the shore terminal is below the pressure required for crude oil washing, provision shall be made that such an adequate pressure to the washing machines can be maintained in accordance with 2.2.1.4-.2. This requirement shall be met with any one cargo pump out of action. The minimum supply pressure required for crude oil washing shall be specified in the Operations and Equipment Manual. Should this minimum supply pressure not be obtainable, crude oil washing operations shall not be carried out.
- .6 Pumps shall be in accordance with the *Rules for the classification of ships, Part 8 - Piping* and *Part 9 - Machines*.

2.2.1.5 Stripping system

- .1 The design of the system for stripping crude oil from the bottom of every cargo tank shall be to the satisfaction of the *Register*.
- .2 The design and capacity of the tank stripping system shall be such that the bottom of the tank being cleaned is kept free of accumulations of oil and sediment towards completion of the tank washing process.
- .3 The stripping system shall be capable of removing oil at a rate of 1,25 times the total throughput of all the tank cleaning

machines to be operated simultaneously when washing the bottom of the cargo tanks or during any stage of the bottom washing as specified in the Operations and Equipment Manual.

- .4 Means such as level gauges, hand dipping and stripping system performance gauges as referred to in 2.2.1.5-.10 shall be provided for checking that the bottom of every cargo tank is dry after crude oil washing. Suitable arrangements for hand dipping must be provided at the aftermost portion of a cargo tank and in three other suitable locations unless other approved means are fitted for efficiently ascertaining that the bottom of every cargo tank is dry. The cargo tank bottom shall be considered *dry* if there is no more than a small quantity of oil near the stripping suction with no accumulation of oil elsewhere in the tank. Level indicators system shall be of closed type (water-gas tight).
- .5 Every oil tanker delivered after 1st June 1982, required to be provided with segregated ballast tanks or fitted with a crude oil washing system, shall comply with the following requirements:
- .1 Oil piping is to be so designed and installed that oil retention in the lines is minimised.
 - .2 Means shall be provided to drain all cargo pumps and all oil lines at the completion of cargo discharge, where necessary, by connection to a stripping device. The line and pump draining shall be capable of being discharged both to a cargo tank or a slop tank and ashore. For discharge ashore a special small diameter line shall be provided and shall be connected outboard of the ship's manifold valves. The cross-sectional area of this line shall not exceed 10% of that of a main cargo discharge line.
- .6 Every crude oil tanker delivered on or before 1 June 1982, required to be provided with segregated ballast tanks or fitted with a crude oil washing system, shall comply with 2.2.1.5-.5.2.
- Where small diameter line is already fitted on an oil tanker delivered on or before 1 June 1982, a cross-sectional area of not more than 25% of that of a main cargo discharge line may be accepted by the *Register*.
- .7 In crude oil tankers having individual cargo pumps in each tank, each pump having an individual piping system, dispensation from the required special small diameter line may be given in cases where the combined amount of oil left in the tank after stripping and the volume of oil in the piping system from the manifold to the tank is less than 0,00085 times the volume of the cargo tank. If a deep well cargo pump system is provided with an evacuating system for retained oil, the above consideration should also apply.
- .8 The means for stripping oil from the cargo tanks shall be by positive displacement pump, self-priming centrifugal pump or eductor or other methods to the satisfaction of the *Register*. Where a stripping line is connected to a number of tanks, means shall be provided for isolating each tank not being stripped at that particular time.
- .9 The internal structure of the tank shall be such that drainage of oil to the tank suction of the stripping system is adequate to meet the requirements of 2.2.1.5-.2 and 2.2.1.5-.4. Care shall be taken that both longitudinal and transverse drainage are satisfactory and shall be verified during the inspection required by 2.1.5.2.
- .10 Equipment shall be provided for monitoring the efficiency of the stripping system. All such equipment shall have remote read-out facilities in the cargo control room or in some other safe and convenient place easily accessible to the officer in charge of cargo and crude oil washing operations. Where a stripping pump is provided, the monitoring equipment shall include, as appropriate, a flow indicator, or a stroke counter or a revolution counter, and pressure gauges at the inlet and discharge connections of the pump or equivalent. Where eductors are provided, the monitoring equipment shall include pressure gauges at the driving fluid intake and at the discharge and a pressure/vacuum gauge at the suction intake.
- .11 The trim conditions for crude oil washing given in the *Operations and Equipment Manual* shall be adhered to.
- .12 Connection of a small diameter line to the cargo manifold piping is given on figure 2.2.1.5-.12.

2.2.1.6 Ballast lines

Where a separate ballast water system for ballasting cargo tanks is not provided, the arrangement shall be such that the cargo pump, manifolds and pipes used for ballasting can be safely and effectively drained of oil before ballasting.

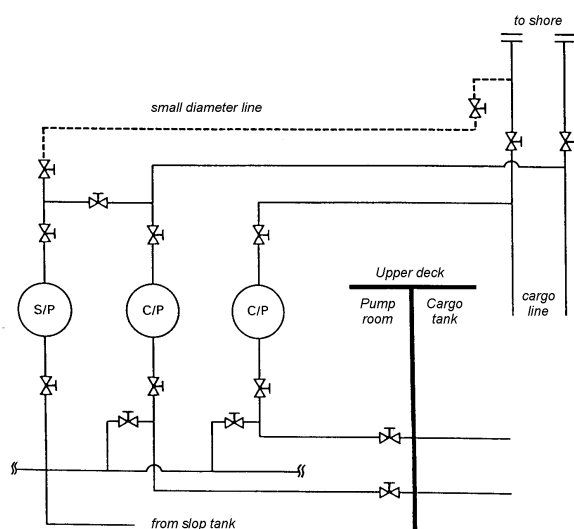

Figure 2.2.1.5-12
Connection of a small diameter line to the manifold piping

2.2.2 Segregated ballast tanks

2.2.2.1 Every crude oil tanker of 20,000 tons dead-weight and above and every product carrier of 30,000 tons dead-weight and above delivered after 1st June 1982 shall be provided with segregated ballast tanks.

2.2.2.2 The capacity of the segregated ballast tanks shall be so determined that the ship may operate safely on ballast voyages without recourse to the use of cargo tanks for water ballast except as provided for in 2.2.2.3 or 2.2.2.4. In all cases, however, the capacity of segregated ballast tanks shall be at least such that, in any ballast condition at any part of the voyage, including the conditions consisting of lightweight plus segregated ballast only, the ship's draughts and trim can meet each of the following requirements:

- .1 the moulded draught amidships (d_m) in metres (without taking into account any ship's deformation) shall not be less than:

$$d_m = 2,0 + 0,02 \cdot L \quad (2.2.2.2-1)$$
 where:
 L -length, see 2.1.2.26
- .2 the draughts at the forward and after perpendiculars shall correspond to those determined by the draught amidships (d_m) as specified in formula 2.2.2.2-1, in association with the trim by the stern of not greater than $0,015 L$; and
- .3 in any case the draught at the after perpendicular shall not be less than that which is necessary to obtain full immersion of the propeller(s).

Provision may be made for emergency discharge of the segregated ballast by means of a connection to a cargo pump through a portable spool piece. In this case non-return valves should be fitted on the segregated ballast connections to prevent the passage of oil to the segregated ballast tanks. The portable spool piece should be mounted in a conspicuous position in the pump-room and a permanent notice restricting its use should be prominently displayed adjacent to it.

2.2.2.3 In no case shall ballast water be carried in cargo tanks, except:

- .1 on those rare voyages when weather conditions are so severe that, in the opinion of the master, it is necessary to carry additional ballast water in cargo tanks for the safety of the ship; and
- .2 in exceptional cases where the particular character of the operation of an oil tanker renders it necessary to carry ballast water in excess of the quantity required under paragraph 2.2.2.2, provided that such operation of the oil tanker falls under the category of exceptional cases as established by the Organisation.

Such additional ballast water shall be processed and discharged in compliance with 2.4.3 and an entry shall be made in the *Oil Record Book*, Part II.

2.2.2.4 In the case of crude oil tankers delivered after 1st June 1982, the additional ballast permitted in 2.2.2.3 shall be carried in cargo tanks only if such tanks have been crude oil washed in accordance with 2.2.1 before departure from an oil unloading port or terminal.

2.2.2.5 Three formulations are set forth as guidance concerning minimum draught requirements for segregated ballast tankers below 150 metres in length.

- .1 Formulation A
 - .1 mean draught = $0,200 + 0,032 \cdot L$ [m]
 - .2 maximum trim = $(0,024 - 6 \cdot 10^{-5} L) \cdot L$

The ballast conditions represent sailing condition in weather up to and including Beaufort 5.

- .2 Formulation B
 - .1 minimum draught at bow = $0,700 + 0,0170 \cdot L$ [m]
 - .2 minimum draught at stern = $2,300 + 0,030 \cdot L$ [m]
 or
 - .3 minimum mean draught = $1,550 + 0,023 \cdot L$ [m]
 - .4 maximum trim = $1,600 + 0,013 \cdot L$ [m]

These formulae are based on a Sea 6 (International Sea Scale).

- .3 Formulation C
 - .1 minimum draught aft = $2,0000 + 0,0275 \cdot L$ [m]
 - .2 minimum draught forward = $0,5000 + 0,0225 \cdot L$ [m]

These expressions provide for certain increased draughts to aid in the prevention of propeller emergence and slamming in higher length ships.

2.2.2.6 Subject to the provisions of 2.2.2.7 every crude oil tanker of 40 000 tons dead-weight and above delivered on or before 1st June 1982 shall be provided with segregated ballast tanks and shall comply with the requirements of 2.2.2.2 and 2.2.2.3.

2.2.2.7 Crude oil tankers referred to in 2.2.2.6 may, in lieu of being provided with segregated ballast tanks, operate with a cargo tank cleaning procedure using crude oil washing in accordance with 2.2.1 unless the crude oil tanker is intended to carry crude oil which is not suitable for crude oil washing.

2.2.2.8 Every product carrier of 40,000 tons dead-weight and above delivered on or before 1st June 1982 shall be provided with segregated ballast tanks and shall comply with the requirements of 2.2.2.2 and 2.2.2.3, or alternatively operate with dedicated clean ballast tanks in accordance with the following provisions:

- .1 The product carrier shall have adequate tank capacity, dedicated solely to the carriage of clean ballast to meet the requirements of 2.2.2.2 and 2.2.2.3.
- .2 The arrangements and operational procedures for dedicated clean ballast tanks shall comply with the requirements established by the *Register*. Such requirements shall contain at least all the provisions of the revised *Specifications for Oil Tankers with Dedicated Clean Ballast Tanks* adopted by the Organisation by resolution A.495(XII).
- .3 The product carrier shall be equipped with an oil content meter, approved by the *Register* on the basis of specifications recommended by the Organisation and 2.4.3, to enable supervision of the oil content in ballast water being discharged. The discharge of ballast from clean ballast tanks shall be continuously monitored. Recording of data and automatic operation of oil content meter is not required.
- .4 Every product carrier operating with dedicated clean ballast tanks shall be provided with a *Dedicated Clean Ballast Tank Operation Manual* detailing the system and specifying operational procedures. Such a Manual shall be to the satisfaction of the *Register* and shall contain all the information set out in the Specifications referred to in 2.2.2.8-.2. If an alteration affecting the dedicated clean ballast tank system is made, the Operation Manual shall be revised accordingly.

2.2.2.9 Item 2.2.2.6, 2.2.2.7 and 2.2.2.8 of this Section shall not apply to an oil tanker delivered on or before 1st June 1982 solely engaged in specific trades between:

- .1 ports or terminals within a State Party to the present Convention; or
- .2 ports or terminals of States Parties to the present Convention, where:
 - .1 the voyage is entirely within a Special Area; or
 - .2 the voyage is entirely within other limits designated by the Organisation.

Ports or terminals where cargo is loaded on such voyages are to be provided with reception facilities adequate for the reception and treatment of all the ballast and tank washing water from oil tankers.

2.2.2.10 Any oil tanker which is not required to be provided with segregated ballast tanks in accordance with 2.2.2.1, 2.2.2.6 and 2.2.2.8 may, however, be qualified as a segregated ballast tanker, provided that it complies with the requirements of 2.2.2.2 and 2.2.2.3 or 2.2.2.5 as appropriate.

2.2.2.11 Oil tankers of 70,000 tonnes dead-weight and above delivered after 31st December 1979, as defined in 2.1.2.9, shall be provided with segregated ballast tanks and shall comply with 2.2.2.2, 2.2.2.3 and 2.2.2.4 or 2.2.2.5 as appropriate.

2.2.3 Oil tankers used for the storage of oil

2.2.3.1 When an oil tanker is used for the storage of oil and its propulsion machinery arrangements have been so modified as to immobilise the ship, such a tanker is not required to comply with the provisions for segregated ballast tanks, clean ballast tanks, crude oil washing and double hull and double bottom.

2.2.3.2 When an oil tanker is used as a floating facility to receive dirty ballast discharged from oil tankers, such a tanker is not required to comply with the provisions for segregated ballast tanks, clean ballast tanks, crude oil washing and double hull and double bottom.

2.2.4 Slop tanks

2.2.4.1 Any oil tanker of 150 tons gross tonnage and above and ships other than oil tankers which are provided with tanks for carriage of oil of an aggregate capacity of 1000 m³ and above shall be provided with slop tank arrangements in accordance with the requirements of paragraph 2.2.4.2, for cleaning the cargo tanks and transferring the dirty ballast residue and tank washings from the cargo tanks into a slop tank approved by the *Register*. In oil tankers delivered on or before 31st December 1979 any cargo tank may be designated as a slop tank.

In this system, arrangements shall be provided to transfer the oily waste into a slop tank or combination of slop tanks in such a way that any effluent discharged into the sea will be such as to comply with 2.4.

2.2.4.2 The arrangements of the slop tank or combination of slop tanks shall have a capacity necessary to retain the slop generated by tank washings, oil residues and dirty ballast residues. The total capacity of the slop tank or tanks shall not be less than 3% of the oil carrying capacity of the ship, except that the *Register* may accept:

- .1 2% for such oil tankers where the tank washing arrangements are such that once the slop tank or tanks are charged with washing water, this water is sufficient for tank washing and, where applicable, for providing the driving fluid for eductors, without the introduction of additional water into the system;
- .2 2% where segregated ballast tanks or dedicated clean ballast tanks are provided or where a cargo tank cleaning system using crude oil washing is fitted in accordance with 2.2.1. This capacity may be further reduced to 1,5% for such oil tankers where the tank washing arrangements are such that once the slop tank or tanks are charged with washing water, this water is sufficient for tank washing and, where applicable, for providing the driving fluid for

eductors, without the introduction of additional water into the system; and

- 3 1% for combination carriers where oil cargo is only carried in tanks with smooth walls. This capacity may be further reduced to 0,8% where the tank washing arrangements are such that once the slop tank or tanks are charged with washing water, this water is sufficient for tank washing and, where applicable, for providing the driving fluid for eductors, without the introduction of additional water into the system.

2.2.4.3 Oil tankers of 70,000 tons dead-weight and above delivered after 31st December 1979 shall be provided with at least two slop tanks.

2.2.4.4 Slop tanks shall be so designed particularly in respect of the position of inlets, outlets, baffles or weirs where fitted, so as to avoid excessive turbulence and entrainment of oil or emulsion with the water.

2.2.4.5 The requirements of 2.2.4.1 to 2.2.4.4 shall not apply to oil tankers of less than 150 gross tonnage, for which the control of discharge of oil under 2.4 shall be effected by the retention of oil on board with subsequent discharge of all contaminated washings to reception facilities. The total quantity of oil and water used for washing and returned to a storage tank shall be recorded in the Oil Record Book, Part II. This total quantity shall be discharged to reception facilities unless adequate arrangements are made to ensure that any effluent which is allowed to be discharged into the sea is effectively monitored to ensure that the provisions of 2.4 are complied with.

2.2.4.6 The Administration may waive the requirements of 2.2.4.1 to 2.2.4.4 for any oil tanker which engages exclusively on voyages both of 72 hours or less in duration and within 50 nautical miles from the nearest land, provided that the oil tanker is engaged exclusively in trades between ports or terminals within a State Party to the present Convention. Any such waiver shall be subject to the requirement that the oil tanker shall retain on board all oily mixtures for subsequent discharge to reception facilities and to the determination by the Administration that facilities available to receive such oily mixtures are adequate.

2.2.4.7 The requirements of 2.4.1.4, 2.4.4 and 2.2.4.1 to 2.2.4.4 shall not apply to oil tankers carrying asphalt or other products subject to the provisions of this Section, which through their physical properties inhibit effective product/water separation and monitoring, for which the control of discharge under 2.4 shall be effected by the retention of residues on board with discharge of all contaminated washings to reception facilities.

2.2.4.8 If arrangements for machinery space bilge discharges into slop tanks are provided, they shall incorporate adequate means to prevent any backflow of liquid cargo and gases into the machinery spaces.

2.3 OIL FILTERING EQUIPMENT

2.3.1 General requirements

2.3.1.1 Every ship of gross tonnage 400 tons and over but less than 10 000 tons shall be provided with an oil filtering equipment except those referred to in 2.6.3.

2.3.1.2 Every ship less than 400 GT shall be provided with the equipment referred to in 2.3.1.1, or tanks referred to in 2.6.3, in agreement with the *Register*.

2.3.1.3 Oil filtering equipment shall be designed to preclude the possibility of discharging the effluent with oil content exceeding 15 ppm and shall be type approved by the *Register*.

2.3.2 15 ppm bilge separator

2.3.2.1 The 15 ppm Bilge Separator should be strongly constructed and suitable for shipboard use, bearing in mind its intended location on the ship. The 15 ppm bilge separator shall be capable of operating under ambient conditions set forth in the *Rules for the classification of ships, Part 7 - Machinery installation*, Section 1.6.

2.3.2.2 It should, if intended to be fitted in locations where flammable atmospheres may be present, comply with the relevant safety regulations for such spaces. Any electrical equipment which is part of the 15 ppm Bilge Separator should be based in a non-hazardous area, or should be certified by the *Register* as safe for use in a hazardous area. Any moving parts which are fitted in hazardous areas should be arranged so as to avoid the formation of static electricity.

2.3.2.3 Oil filtering equipment operating under pressure shall be provided with safety devices set to:

$$P_{sig} = 1,1 \cdot p \quad [\text{MPa}]$$

where:

$$p - \text{working pressure, [MPa]}$$

2.3.2.4 The parts of oil filtering equipment operating under pressure are to be subjected to a hydraulic test referred to in the *Rules for the classification of Ships, Part 9 - Machines*, Section 1.3.

The parts are allowed to be separately tested with test pressure, which is determined on the basis of the working pressure.

2.3.2.5 Parts and assemblies which are subject to periodical inspection and maintenance shall be easily accessible.

2.3.2.6 Provisions shall be made to empty the oil filtering equipment.

2.3.2.7 When the oil filtering equipment is designed with preheating of oily water, it shall be performed by means of steam or hot water coils. Electrical heating may be permitted provided that the requirements set forth in the *Rules for the classification of ships, Part 12 - Electrical equipment*, 15.3 are fulfilled.

2.3.2.8 Oil filtering equipment shall be designed to function automatically. However, fail-safe arrangements to avoid any discharge in case of malfunction should be provided.

2.3.2.9 Oil filtering equipment shall be fitted with pressure, temperature and level controls as well as alarm arrangements.

2.3.2.10 Changing the feed to the 15 ppm Bilge Separator from bilge water to oil, bilge water to emulsified bilge water, or from oil and/or water to air should not result in the discharge overboard of any mixture containing more than 15 ppm of oil.

2.3.2.11 The system should require the minimum of attention to bring it into operation. In the case of equipment used for engine room bilge, there should be no need for any adjustment to valves and other equipment to bring the system into operation. The equipment should be capable of operating for at least 24 hours of normal duty without attention.

2.3.2.12 Oil filtering equipment may include any combination of a separator, filter or coalescer, and also a single unit designed to produce an effluent with oil content not exceeding 15 ppm.

2.3.2.13 A centrifugal separator if included into oil filtering equipment, shall comply with the requirements of the *Rules for the classification of ships, Part 9 - Machines*, Section 5.4.

2.3.2.14 Separators, filters, pumps and other equipment shall be fitted with trays where there is a possibility of oily water leakage, in accordance with the requirements of the *Rules for the classification of ships, Part 8 - Piping*, Section 8.5.

2.3.2.15 The detailed requirements of oil filtering equipment are specified in the IMO Res. MEPC.107(49).

2.3.3 Installation requirements

2.3.3.1 For future inspection purposes on board ship, a sampling point should be provided in a vertical section of the water effluent piping as close as is practicable to the 15 ppm bilge separator outlet.

Recirculating facilities should be provided to bilge or to oily bilge water tank, after and adjacent to the overboard outlet of the stopping device, to enable the oil filtering equipment, including the 15 ppm bilge alarm and the automatic stopping device, to be tested with the overboard discharge closed, see figure 2.3.3.1.

The recirculating facility should be so configured as to prevent under all operating conditions any by-pass of the oily water separator.

2.3.3.2 The discharge piping system of the 15 ppm bilge water separator shall be completely separate from the bilge pumping and ballast water system.

2.3.3.3 The capacity of the supply pump should not exceed 110% of the rated capacity of the 15 ppm Bilge Separator with size of pump and motor to be stated on the Certificate of Type Approval.

2.3.3.4 The 15 ppm bilge separator should be fitted with a permanently attached plate giving any operational or installation limits considered necessary by the manufacturer or the *Register*.

2.3.3.5 A vessel fitted with a 15 ppm Bilge Separator should, at all times, have on board a copy of the *Operating and Maintenance manual*.

2.4 OIL DISCHARGE MONITORING AND CONTROL SYSTEMS

2.4.1 General requirements

2.4.1.1 Every ship of gross tonnage 10 000 tons and over as well as a ship of gross tonnage 400 tons and over carrying large quantity of fuel oil and which have to carry ballast water in fuel oil tanks, shall be provided with oil filtering equipment complying with 2.3.1.3.

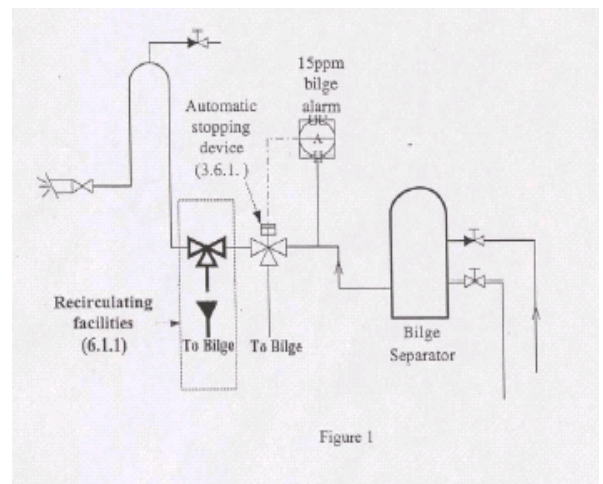

Figure 2.3.3.1
Recirculating facilities

In addition it shall be provided with equipment in 2.4.2.

2.4.1.2 Requirements in 2.4.1.1 shall not be mandatory for ships under conditions stated in 2.6.4.

2.4.1.3 Ship may discharge oily mixture into the sea in special areas when provided with oil filtering equipment and monitoring and control of discharge when oil content of the effluent exceeds 15 ppm, in compliance with the requirements of 2.4.2.

2.4.1.4 Oil tankers of gross tonnage 150 tons and above as well as ships other than oil tankers which are provided with tanks for carriage of oil of 1000 m³ and above, shall be fitted with oil discharge monitoring and control system type approved by the *Register* (see 2.4.3). Ships other than oil tankers provided with the tanks intended for carriage of oil of an aggregate capacity of 200 m³ to 1000 m³ may retain oily mixtures on board with subsequent discharge to reception facilities.

2.4.1.5 The requirement in 2.4.1.4 and 2.4.4 shall not be mandatory for:

- 1 Oil tankers engaged exclusively on voyages both of 72 hours or less in duration and within 50 nautical miles from the nearest land, provided that the oil tanker is engaged exclusively in trades between ports or terminals within a State Party to the present Convention. Oil tankers shall retain

on board all oily mixtures for subsequent discharge to reception facilities.

- .2 Oil tankers engaged exclusively in one or more voyages:
 - .1 within a special area, or
 - .2 within Arctic waters, or
 - .3 within 50 nautical miles from the nearest land, outside a special area or Arctic waters.
- .3 Oil tankers delivered on or before 1st June 1982, of 40 000 tons dead-weight or above, as referred to in 2.2.2.9.
- .4 Oil tankers of less than 150 gross tonnage as specified in 2.2.4.5.

2.4.1.6 In Arctic waters any discharge into the sea of oil or oily mixtures from any ship shall be prohibited.

Subject to approval of the Administration, a category A ship constructed before 1st January 2017 that cannot comply with previous paragraph and is operating continuously in Arctic waters for more than 30 days shall comply with that paragraph not later than the first intermediate or renewal survey, whichever comes first, one year after 1st January 2017. Until such date these ships shall use oil filtering equipment in accordance with 2.4.2 for discharge into the sea of processed oil or oily mixtures from machinery spaces.

2.4.2 Equipment for monitoring and control of discharge of oily mixture from machinery spaces

2.4.2.1 The oily mixture, in case of oil tankers, is not to be mixed with oil cargo residues and is not to originate from cargo pump room bilge.

2.4.2.2 15 ppm bilge alarm

- .1 The 15 ppm Bilge Alarm should resist corrosion in conditions of the marine environment.
- .2 The 15 ppm Bilge Alarm should, if intended to be fitted in locations where flammable atmosphere may be present, comply with the relevant safety regulations for such spaces. Any electrical equipment which is part of the 15 ppm Bilge Alarm should be placed in a non-hazardous area, or should be certified by the *Register* as safe for use in a hazardous atmosphere. Any moving parts which are fitted in hazardous areas should be arranged so as to avoid the formation of static electricity.
- .3 The 15 ppm Bilge Alarm should not contain or use any substance of a dangerous nature, unless adequate arrangements, acceptable to the *Register*, are provided to eliminate any hazards introduced thereby.
- .4 A ppm display should be provided. The ppm display should not be affected by emulsions and/or the type of oil. It should not be necessary to calibrate the 15 ppm Bilge Alarm on board ship, but onboard testing according to the manufacturers' instructions shall be permitted. The accuracy

of the readings should at all times remain within ± 5 ppm.

- .5 The response time of the 15 ppm Bilge Alarm, that is, the time which elapses between an alteration in the sample being supplied to the 15 ppm Bilge Alarm and the ppm display showing the correct response, should not exceed 5 seconds.
- .6 The 15 ppm Bilge Alarm should be fitted with an electrical/electronic device which should be pre-set by the manufacturer to activate when the effluent exceeds 15 ppm. This should also operate automatically if at any time the 15 ppm Bilge Alarm should fail to function, require a warm-up period or otherwise be de-energised.
- .7 It is recommended that a simple means be provided aboard ship to check on instrument drift, repeatability of the instrument reading, and the ability to re-zero the instrument.
- .8 The 15 ppm Bilge Alarm should record date, time and alarm status, and operating status of the 15 ppm Bilge Separator. The recording device should also store data for at least eighteen months and should be able to display or print a protocol for official inspections as required. In the event the 15 ppm Bilge Alarm is replaced, means should be provided to ensure the data recorded remains available on board for 18 months.
- .9 To avoid wilful manipulation of 15 ppm Bilge Alarms, the following items should be included:
 - .1 every access of the 15 ppm Bilge Alarm beyond the essential requirements of paragraph .7 requires the breaking of a seal; and
 - .2 the 15 ppm Bilge Alarm should be so constructed that the alarm is always activated whenever clean water is used for cleaning or zeroing purposes.
- .10 The accuracy of the 15 ppm bilge alarms should be checked at IOPPC renewal surveys according to the manufacturers' instructions. Alternatively the unit may be replaced by a calibrated 15 ppm bilge alarm. The calibration certificate for the 15 ppm bilge alarm should be checked for validity at IOPPC surveys. The accuracy checks can only be done by the manufacturer or persons authorized by the manufacturer by calibration and testing of the equipment at intervals not exceeding five years or within the term specified in the manufacturer's instructions, whichever is shorter.

2.4.2.3 Automatic stopping device

- .1 Electrical/electronic device shall give visual and audible alarm in cases stated in 2.4.2.2-.6.

- .2 Visual and audible alarm arrangements shall be connected to the discharge control position.
- .3 The automatic stopping device should consist of a valve arrangement installed in the effluent outlet line of the 15 ppm Bilge Separator which automatically diverts the effluent mixture from being discharged overboard back to the ship's bilge or bilge tank when the oil content of the effluent exceeds 15 ppm, see figure 2.3.3.1.

2.4.2.4 Installation requirements

- .1 The layout of the installation should be arranged so that the overall response time (including the response time of the 15 ppm Bilge Alarm) between an effluent discharge from the 15 ppm Bilge Separator exceeding 15 ppm, and the operation of the Automatic Stopping Device preventing overboard discharge, should be as short as possible and in any case not more than 20 seconds.
- .2 The arrangement on board ship for the extraction of samples from the 15 ppm Bilge Separator discharge line to the 15 ppm Bilge Alarm should give a truly representative sample of the effluent with an adequate pressure and flow.
- .3 A vessel fitted with a 15 ppm Bilge Alarm should, at all times, have on board a copy of the Operating and Maintenance manuals.

2.4.2.5 Detailed requirements of equipment for monitoring and control of discharge of oily mixture from machinery spaces are specified in the IMO Res. MEPC.107(49) and IMO Res. MEPC.285(70).

2.4.3 Oil discharge monitoring and control system

2.4.3.1 General requirements

- .1 Detailed requirements for this equipment are specified in IMO Res. MEPC.108(49) and IMO Res. MEPC.240(65).
Bio-fuel blends containing 75% or more of petroleum oil, on or after 1st January 2016, may be carried when the ship's ODME is in compliance with IMO Res. MEPC.240(65).
- .2 Oil discharge monitoring and control system shall be capable of working under ambient conditions referred to in the *Rules for the classification of ships, Part 7 - Machinery installation*, Section 1.6 and of complying with the requirements in the *Rules for the classification of ships, Part 12 - Electrical Equipment*, paragraph 5.1.3 and *Part 13 - Automation*, Section 2.5.
- .3 Oil Discharge Monitoring and Control System should employ a control unit and

be fitted with a starting interlock and overboard discharge control. System shall come into operation when there is any discharge of effluent into the sea and shall ensure that any discharge of oily mixture is automatically stopped when the instantaneous rate of discharge of oil exceeds that permitted in 2.4.3.7-.2.

- .4 Any failure of the system shall stop the discharge. In case of failure in the system, a manually operated alternative method in accordance with 2.4.3.11 may be used.
- .5 The instrument should be designed to ensure that user access is restricted to essential controls. Access beyond these controls should be available for emergency maintenance and temporary repair but must require the breaking of security seals or activation of another device which indicates an entry to the equipment.
The seals should be of a design that only the manufacturer or his agent can replace the seals or reset the system following inspection and permanent repairs to the equipment.
- .6 The unit may have several scales as appropriate for its intended use. The recording device fitted to a meter which has more than one scale should indicate the scale which is in use.
- .7 It is recommended that simple means be provided aboard ship to check on instrument drift, repeatability of the instrument reading, and the ability to re-zero the instrument.
- .8 Manufacturer recommended spares for the ODME should be carried to ensure the operation of the equipment.
- .9 Instructions as to the operation of the system shall be in accordance with an operational manual approved by the *Register*. They shall cover manual as well as automatic operations and shall be intended to ensure that at no time shall oil or oily mixtures be discharged except in compliance with the conditions specified in 2.4.3.7-.2. The routine maintenance of the Oil Discharge Monitoring Equipment and troubleshooting procedures should be clearly defined by the manufacturer in the *Operating and Maintenance Manual*.
Oil discharge monitoring and control system operational manual is to contain all the details necessary to operate and maintain the system and shall include at least the information as indicated in IACS UI MPC2.

2.4.3.2 Monitoring and control system

- .1 The monitoring system should be capable of effectively monitoring and controlling

the discharge of any effluent into the sea through those overboard discharge outlets permitted by 2.5.1 which, in the opinion of the *Register*, are necessary to fulfil the operational requirements of the oil tanker.

- .2 The monitoring system should function effectively under all environmental conditions which oil tankers are normally assumed to encounter, and should be designed and constructed to satisfy the specifications for environmental testing specified in part 2 of the annex to Guidelines and Specifications contained in IMO Res. MEPC.108(49). Moreover:
 - .1 the system should be so designed that no discharge of dirty ballast or other oil-contaminated water from the cargo tank areas can take place unless the monitoring system is in the normal operating mode and the relevant sampling point has been selected;
 - .2 preferably the system should sample the effluent discharge from a minimum number of discharge outlets and be so arranged that discharge overboard can take place via only one outlet at a time;
 - .3 where it is intended that more than one line be used for simultaneous discharging purposes, one oil content meter, together with a flow meter, should be installed in each discharge line. These instruments should be connected to a common processor; and
 - .4 in order to avoid alarms due to short-term high oil concentration signals (spikes) causing indications of high instantaneous rates of discharge, the short-term high ppm signal may be suppressed for a maximum of 10 s. Alternatively, the instantaneous rate of discharge may be continuously averaged during the preceding 20 s or less as computed from instantaneous ppm values of the oil content meter readings received at intervals not exceeding 5 s.
- .3 The monitoring system should comprise:
 - .1 an oil content meter to measure the oil content of the effluent in ppm. The meter should be approved in accordance with the provisions contained in the annex to Guidelines and Specifications contained in IMO resolution MEPC.108(49) and be certified to take into account the range of cargoes carried;
 - .2 a flow rate indicating system to measure the rate of effluent being discharged into the sea;
 - .3 a ship speed indicating device to give the ship's speed in knots;
 - .4 a ship position indicating device to give the ship's position, latitude and longitude;
 - .5 a sampling system to convey a representative sample of the effluent to the oil content meter;
 - .6 an overboard discharge control to stop the overboard discharge;
 - .7 a starting interlock to prevent the discharge overboard of any effluent unless the monitoring system is fully operational; and
 - .8 a control section comprising:
 - .1 a processor, which accepts signals of oil content in the effluent, the effluent flow rate and the ship's speed and computes these values into litres of oil discharged per nautical mile and the total quantity of oil discharged;
 - .2 means to provide alarms and command signals to the overboard discharge control;
 - .3 a recording device to provide a record of data in accordance with 2.4.3.9;
 - .4 a data display to exhibit the current operational data in accordance with 2.4.3.10;
 - .5 a manual override system to be used in the event of failure of the monitoring system; and
 - .6 means to provide signals to the starting interlock to prevent the discharge of any effluent before the monitoring system is fully operational.
- .4 Each main component of the oil content monitoring system should be fitted with a name-plate, properly identifying the component by assembly drawing number, type or model number and serial number, as appropriate.
- .5 If installed in a hazardous area, the electrical components of the monitoring system should meet the appropriate safety requirements laid down for these areas.

2.4.3.3 Oil content meter

- .1 An oil content meter should satisfy the test and performance specifications contained in part 1 of the Annex to Guidelines and Specifications contained in IMO Res. MEPC.108(49) and should conform with the general requirements contained in 2.4.3.3.
- .2 The accuracy of meters designed to monitor a wide range of oil content should be such that the reading will represent the actual oil content of the sample being tested

within ± 10 ppm or $\pm 10\%$, whichever is greater. The accuracy should remain within the above limit despite the presence of contaminants other than oil, such as entrained air, rust, mud and sand.

- .3 The meter should be designed so that it functions within the above limit when the power supply (in the form of electricity, compressed air, etc.) is varied by 10% from the value for which the meter is designed.
- .4 It is desirable that the reading should not be affected by the type of oil. If it is, it should not be necessary to calibrate the meter on board ship, but pre-set alterations in the calibration may be made in accordance with the manufacturer's instructions. In the latter case, means should be available to check that the correct calibration has been selected for the oil in question. The accuracy of the readings should at all times remain within the limit specified in 2.4.3.3-2.
- .5 The meter may have several scales as appropriate for its intended use. The full range of the scale shall not be less than 1000 ppm.
- .6 The response time of the meter shall not exceed 20 seconds.
- .7 The meter shall have simple means to enable the ship's crew to check the functioning of the electrical and electronic circuitry of the meter by introduction of a simulated signal corresponding approximately to half the full scale reading of the meter. It shall also be possible for qualified personnel to recalibrate the meter on board the oil tanker.
- .8 The meter should, if intended to be fitted in locations where flammable atmospheres may be present, comply with the relevant safety regulations for such spaces. Any electrical equipment which is part of the meter should be placed in a non-hazardous area, or should be certified by the *Register* as safe for use in a hazardous atmosphere. Any moving parts which are fitted in hazardous areas should be so arranged as to avoid the formation of static electricity.
- .9 The meter should not contain or use any substance of a dangerous nature, unless adequate arrangements, acceptable to the *Register*, are provided to eliminate any hazard introduced thereby.
- .10 The meter should resist corrosion in conditions of the marine environment.
- .11 The meter should be constructed from materials compatible with the liquids to be tested.

2.4.3.4 Sampling system

- .1 Sampling points should be so located that relevant samples can be obtained from those outlets that are used for operational discharges in accordance with 2.4.3.2-1. The sampling probes located in the over-board discharge lines and the piping system connecting the sampling probes to the oil content meter should meet the requirements of 2.4.3.4.
- .2 The piping and probes shall be of a material resistant to fire, corrosion and oil, and be of adequate strength, properly jointed and supported.
- .3 The system shall have a stop valve fitted adjacent to each probe, except that, where the probe is mounted in a cargo line, two stop valves shall be fitted in series, in the sample line. One of these may be the remote controlled sample selector valve.
- .4 Sampling probes shall be arranged for easy withdrawal and shall be mounted at an accessible location in a vertical section of the discharge line. Should it be necessary to fit sampling probes in a horizontal section of the discharge line, it shall be ascertained, during the installation survey, that the pipe runs full of liquid at all times during the discharge of the effluent. Sampling probes shall normally penetrate inside the discharge pipe to a distance of $1/4$ the diameter of that pipe.
- .5 The design of probes and piping shall be such as to minimise their clogging by oil, oily residue and other matter. Means shall be provided for cleaning the probes and piping system by the provision of permanent clean water flushing arrangements or an equivalent method.
- .6 The velocity of the fluid in the piping should be such that, taking into consideration the length of the piping, the overall response time should be as short as possible between an alteration in the mixture being pumped and the alteration in the meter reading and in any case not more than 40 s, including the response time of the meter.
- .7 The location of sampling probes in relation to any point of flow diversion to a slop tank should be selected with regard to the need for sampling the oily water in the recirculation mode.
- .8 The arrangements for driving the sampling pump or any other pumps used in the system should have regard to the safety requirements of the space in which the pump is located. Any bulkhead penetration between a hazardous and a non-hazardous

area should be of a design approved by the *Register*.

- .9 The flushing arrangement shall be such that where necessary it can be utilised for test-running and stabilising the oil content meter and correcting for zero setting.
- .10 Sample water returning to the slop tank shall not be allowed to free-fall into the tank. In tankers equipped with an inert gas system a U - pipe seal of adequate height shall be fitted in the piping leading to a slop tank.
- .11 A valve should be provided for the manual collection of samples from the inlet piping to the meter at a point downstream of any sampling pump or at an equivalent location satisfactory to the *Register*.

2.4.3.5 Flow rate indicating system

- .1 A flow meter for measuring the rate of discharge shall be installed in a vertical section of a discharge line or in any other section of a discharge line as appropriate, so as to be always filled with the liquid being discharged.
- .2 A flow meter should employ an operating principle which is suitable for shipboard use and, where relevant, can be used in large diameter pipes.
- .3 A flow meter should be suitable for the full range of flow rates that may be encountered during normal operation. Alternatively, arrangements such as the use of two flow meters of different ranges or a restriction of the operational flow rate range may be necessary to meet this requirement.
- .4 The flow meter, as installed, shall have an accuracy of $\pm 10\%$, or better, of the instantaneous rate of discharge throughout the operating range for discharging the effluent.
- .5 Any component part of the flow meter in contact with the effluent shall be of corrosion-resistant and oil-resistant material of adequate strength.
- .6 The design of the flow metering arrangements shall comply with the safety requirements of the space in which such flow metering arrangements are located.

2.4.3.6 Ship's speed indicating system and ship position indicating device

- .1 The automatic speed signal required for a monitoring system shall be obtained from the ship's speed indicating device by means of a repeater signal. The speed information used may be either speed over

the ground or speed through the water, depending upon the speed measuring equipment installed on board.

- .2 The ship position indicating device shall consist of a receiver for a global navigation satellite system or a terrestrial radio navigation system, or other means, suitable for use at all times throughout the intended voyage to establish and update the ship's position by automatic means.

2.4.3.7 Overboard discharge control arrangement

- .1 The overboard discharge control shall be able to stop the discharge of the effluent into the sea automatically by either closing all relevant overboard discharge valves or stopping all relevant pumps. The discharge control arrangement should be fail-safe so that all effluent discharge is stopped when the monitoring system is not in operation, at alarm conditions, or when the monitoring system fails to function.
- .2 Overboard discharge control arrangement shall activate audio visual alarms and automatically stop the discharge of effluent when:
 - .1 the instantaneous rate of discharge of oil content exceeds 30 liters/per nautical mile;
 - .2 the total quantity of discharged oil exceeds for tankers delivered on or before 31st December 1979 1/15000 of the total quantity of the particular cargo of which the residue formed a part, and for tankers delivered after 31st December 1979 1/30000 of the total quantity of the particular cargo of which the residue formed a part;
 - .3 monitoring system failure:
 - .1 power failure;
 - .2 loss of sample;
 - .3 significant failure of the measuring or recording system;
 - .4 the input of any sensor exceeds the effective capacity of the system.

The provisions of this item shall not apply to the discharge of clean or segregated ballast.

- .3 The alarm indicator of the system should be installed in the cargo control room, where provided, and/or in other places where it will attract immediate attention and action.

2.4.3.8 Processor and transmitting device

- .1 The processor of a control section should receive signals from the oil content meter, the flow rate indicating system and the ship's speed indicating system at time intervals not exceeding five seconds and should automatically compute the following:

- .1 instantaneous rate of discharge of oil in litres per nautical mile; and
 - .2 total quantity of oil discharged during the voyage in cubic metres or litres.
- .2 When the limits imposed by 2.4.3.7-.2.1 and 2.4.3.7-.2.2 are exceeded, the processor should provide alarms and provide command signals to the overboard discharge control arrangement which will cause the discharge of effluent into the sea to stop.
 - .3 The processor should normally include a device for the continuous generation of time and date information. Alternative arrangements for the automatic and continuous reception of time and date information from an external source may be accepted.
 - .4 In the event of power failure the processor should retain its memory in respect to computation of the total quantity of oil discharged, time and date. A printout of data should be obtained when the monitoring system is operating with manual override, but this is not required if, when the power fails, the monitoring system activates the overboard discharge control to stop the discharge of effluent.

2.4.3.9 Recording device

- .1 The recording device of a control section shall include a digital printer, which may be formatted electronically if preferred. The recorded data shall be explicitly identified on the printout. The printout shall be legible and shall remain so once removed from the recording device and shall be retained for at least three years.
- .2 The data to be automatically recorded shall include at least the following:
 - .1 instantaneous rate of discharge of oil [litres per nautical mile];
 - .2 instantaneous oil content, [ppm];
 - .3 total quantity of oil discharged, [m³] or [litres];
 - .4 date and time (GMT);
 - .5 ship's speed, [knots];
 - .6 ship's position, latitude and longitude;
 - .7 effluent flow rate, [m³/h];
 - .8 status of the overboard discharge control or arrangement;
 - .9 oil type selector setting, where applicable;
 - .10 alarm condition;
 - .11 failure (no flow, fault, etc.); and
 - .12 override action (manual override, flushing, calibration, etc.).
 Any information inserted manually as a result of an override action should be identified on the printout.
- .3 Data required in 2.4.3.9-.2 shall be printed out, as applicable, or may be stored

electronically with printout capability, with the following minimum frequency:

- .1 when the discharge is started;
 - .2 when the discharge is stopped;
 - .3 at intervals of not more than 10 min (except when the system is in stand-by mode);
 - .4 when an alarm condition develops;
 - .5 when normal conditions are restored;
 - .6 whenever the computed instantaneous rate of discharge of oil varies by 10 litres per nautical mile;
 - .7 when zero setting or calibration modes are selected; and
 - .8 on manual command.
- .4 The recording device shall be located in a position easily accessible to the person in charge of the overboard discharge operation.

2.4.3.10 Data display

- .1 In addition to the recorded printout, the current data shall be visibly displayed and shall as a minimum contain the following:
 - .1 instantaneous rate of discharge of oil, [litres per nautical mile];
 - .2 total quantity of oil discharged, [m³] or [lit];
 - .3 instantaneous oil content, [ppm];
 - .4 flow rate, [m³/h];
 - .5 ship's speed, [knots]; and
 - .6 status of the overboard discharge control or arrangement.
- .2 The data display should be located in a position easily observed by the person in charge of the overboard discharge operation.

2.4.3.11 Manually operated alternatives in the event of equipment malfunction

The alternative means of obtaining information in the event of a failure in the monitoring system shall be as follows:

- .1 for oil content meter or sampling system: location and measurement of the oil/water interface using the equipment in 2.4.4, visual observation of the surface of the water adjacent to the effluent discharge;
- .2 for flow meter: pump discharge characteristics;
- .3 for ship's speed indicating device: propulsion engine rpm;
- .4 for processor: manual calculation and manual recording; and
- .5 for the overboard discharge control: manual operation of pumps and valves.

2.4.3.12 Installation requirements

- .1 The on-board installation arrangements must be such that satisfactory function of the entire system is obtained and all safety

regulations issued by the relevant Administration are complied with.

- 2 The installation arrangements must conform in each case with those specified and approved under the procedure for documentation approval outlined in 2.1.3.4.
- 3 The installation arrangements must also satisfy all relevant parts of 2.4.3 and all relevant installation instructions provided by the manufacturer of the various items of equipment and components.

2.4.4 Oil/water interface detectors

2.4.4.1 Oil tankers of 150 gross tonnage and above and ships other than oil tankers fitted with cargo spaces which are constructed and utilised to carry oil in bulk of an aggregate capacity of 1000 m³ and above shall be provided with oil/water interface detectors approved by the *Register* for a rapid and accurate determination of the oil/water interface in slop tanks and shall be available for use in other tanks where the separation of oil and water is effected and from which it is intended to discharge effluent direct to the sea.

2.4.4.2 Interface detectors may be permanently installed or portable.

2.4.4.3 Detectors shall be capable of indicating the interface position at any level in the tank.

2.4.4.4 Detectors need not indicate the interface position continuously.

2.4.4.5 If permanently installed equipment based on stationary sensors only is provided, the information obtained about the interface should be at least equivalent to that obtainable from portable equipment when used in a normal operating pattern.

2.4.4.6 The position of permanently installed equipment or the position of the access openings for portable equipment shall be selected with due regard to the internal tank structure and reasonable ship movement.

2.4.4.7 The control and display unit of a permanently installed system shall be located in the cargo control room or similar space.

2.4.4.8 Permanently installed equipment inside the tank shall be able to withstand the impact from the jets of tank cleaning equipment.

2.4.4.9 The equipment may be designed to detect interfaces of liquids having a wide range of density differences.

Detector may be tested for one or several specified applications (e.g. interface between oils and salt water, brackish water or fresh water). The approval document should clearly state the accepted applications and any relevant limitations.

2.4.4.10 The equipment shall be arranged and used with due regard to relevant operational safety precautions.

2.4.4.11 The detector and its associated depth measuring equipment shall be practical, reliable and constructed of materials suitable for use in the marine environment and oil.

2.4.4.12 Detector shall comply with the relevant requirements for use in hazardous areas on oil tankers and shall not interfere with radio communication.

2.4.4.13 The detector shall respond promptly and in a distinctive manner to changes between oil and water.

2.4.4.14 The detector shall be capable to indicate the actual position of oil-water interface within limits ± 25 mm.

2.4.4.15 The instrument shall be capable of being checked on board for correct working.

2.4.4.16 Detailed requirements for this equipment are specified in IMO Res. MEPC.5(XIII).

2.5 OILY-WATER TRANSFER AND DISCHARGE SYSTEM OF PIPING

2.5.1 Oil tanker system of piping

2.5.1.1 Any oil tanker and ships other than oil tankers provided with cargo spaces intended for carriage of oil having the aggregate capacity of 200 m³ and above, shall have a discharge manifold for connection to reception facilities for the discharge of dirty ballast water or oil-contaminated water located on the open deck on both sides of the ship.

2.5.1.2 In every oil tanker of 150 gross tonnage and above, pipelines for the discharge to the sea of ballast water or oil contaminated water from cargo tank areas which may be permitted under 2.4.3 shall be led to the open deck or to the ship's side above the waterline in the deepest ballast condition.

2.5.1.3 In oil tankers of 150 gross tonnage and above delivered after 31st December 1979 means shall be provided for stopping the discharge into the sea of ballast water or oil contaminated water from cargo tank areas, other than those discharges below the waterline permitted under 2.5.1.11, from a position on the upper deck or above located so that the manifold in use referred to in 2.5.1.1 and the discharge to the sea from the pipelines referred to in 2.5.1.2 may be visually observed. Means for stopping the discharge need not be provided at the observation position if a positive communication system such as a telephone or radio system is provided between the observation position and the discharge control position.

2.5.1.4 Credit for reducing oil outflow in case of bottom damage or side damage may be taken into account through the use of an installed cargo transfer system having an emergency high suction in each cargo oil tank, capable of transferring from a breached tank or tanks to segregated ballast tanks or to available cargo tankage if it can be assured that such tanks will have sufficient ullage.

2.5.1.5 Emergency cargo transfer piping, in case of bottom damage or the ship's side damage shall be capable of transferring the oil quantity which corresponds to a half volume of the largest cargo tank involved in two hours of operation according to MARPOL 73/78, Annex I, Regulation 25(5).

2.5.1.6 Suction piping of the emergency cargo transfer system shall be located at least at the height not less than the vertical extent of the bottom damage (v_s) defined in accordance with MARPOL 73/78, Annex I, Regulation 24.

2.5.1.7 The suction well piping located in double bottom shall be fitted with the stop valves or other closing arrangements located at the point of connection to the tank served, to prevent oil outflow in the event of damage to the piping. Such piping shall be installed as high from the bottom shell as possible.

2.5.1.8 Cargo transfer system connecting two or more tanks shall be fitted with the stop valves or similar closing devices for separating the tanks from each other.

2.5.1.9 Lines of piping which run through cargo tanks in a position less than t_c from the ship's side or less than v_c from the ship's bottom (see MARPOL 73/78, Annex I, Regulation 24) shall be fitted with valves or similar closing devices at the point at which they open into any cargo tank.

2.5.1.10 Items 2.5.1.4 to 2.5.1.9 do not apply to oil tankers delivered on or after 1st January 2010. The following provisions regarding piping arrangements shall apply to oil tankers delivered on or after 1st January 2010:

- .1 The pipelines passing through the cargo tanks at a distance less than $0,3B_S$ from the ship's side or less than $0,3D_S$ from the ship's bottom (see MARPOL 73/78, Annex I, Regulation 23(11)) shall be provided with the stop valves or similar closing devices at the point at which they open into any cargo tank.
- .2 Credit for reducing oil outflow through the use of an emergency rapid cargo transfer system or other system arranged to mitigate oil outflow in the event of an accident may be taken into account only after the effectiveness and safety aspects of the system are approved by the Organisation. Submittal for approval shall be made in accordance with the provisions of the Guidelines adopted by IMO Res. MEPC.110(49).
- .3 Every oil tanker of 150 gross tonnage and above which has installed a sea chest that is permanently connected to the cargo pipeline system, shall be equipped with both a sea chest valve and an inboard isolation valve. In addition to these valves, the sea chest shall be capable of isolation from the cargo piping system whilst the tanker is loading, transporting, or discharging cargo by use of a positive means that is to the satisfaction of the *Register*. Such a positive means is a facility that is installed in the pipeline system in order to prevent, under all circumstances, the section of pipeline between the sea chest valve and the inboard valve being filled with cargo.
Positive means may take the form of blanks, spectacle blanks, pipeline blinds, evacuation or vacuum systems, or air or water pressure systems. Evacuation or vacuum systems, or air or water pressure systems are to be equipped with both a pressure gauge and alarm system to enable the continuous monitoring of the status of the pipeline section, and thereby the valve

integrity, between the sea chest and inboard valves.

2.5.1.11 On every oil tanker the discharge of ballast water or oil contaminated water from cargo tank areas shall take place above the waterline, except as follows:

- .1 Segregated ballast and clean ballast may be discharged below the waterline:
 - .1 in ports or at offshore terminals, or
 - .2 at sea by gravity, or
 - .3 at sea by pumps if the ballast water exchange is performed under the provisions of regulation D-1.1 of the *International Convention for the Control and Management of Ships' Ballast Water and Sediments*;
 provided that the surface of the ballast water has been examined either visually or by other means immediately before the discharge to ensure that no contamination with oil has taken place.
- .2 Oil tankers delivered on or before 31st December 1979 which, without modification, are not capable of discharging segregated ballast above the waterline may discharge segregated ballast below the waterline at sea, provided that the surface of the ballast water has been examined immediately before the discharge to ensure that no contamination with oil has taken place.
- .3 Oil tankers delivered on or before 1st June 1982 operating with dedicated clean ballast tanks, which without modification are not capable of discharging ballast water from dedicated clean ballast tanks above the waterline, may discharge this ballast below the waterline provided that the discharge of the ballast water is supervised in accordance with 2.2.2.8-.3.
- .4 On every oil tanker at sea, dirty ballast water or oil contaminated water from tanks in the cargo area, other than slop tanks, may be discharged by gravity below the waterline, provided that sufficient time has elapsed in order to allow oil/water separation to have taken place and the ballast water has been examined immediately before the discharge with an oil/water interface detector referred to in 2.4.4, in order to ensure that the height of the interface is such that the discharge does not involve any increased risk of harm to the marine environment.
- .5 On oil tankers delivered on or before 31st December 1979, at sea dirty ballast water or oil contaminated water from cargo tank areas may be discharged below the waterline, subsequent to or in lieu of the discharge by the method referred to in 2.5.1.11-.4, provided that:
 - .1 a part of the flow of such water is led through permanent piping to a readily accessible location on the upper deck or above where it may be visually

observed during the discharge operation; and

- .2 such part flow arrangements comply with the requirements established by the Administration, which shall contain at least all the provisions of the *Specifications for the Design, Installation and Operation of a Part Flow System for Control of Overboard Discharges* adopted by the Organisation.

2.5.1.12 Systems shall comply with the requirements of the *Rules for the classification of ships, Part 8 - Piping*.

2.5.2 Other ships system of piping

2.5.2.1 Every ship of 400 gross tonnage and above shall be provided with the transfer piping for oily bilge water from the machinery spaces and oil residues into shore reception facilities. The pipeline shall be led on the ship's both sides. In smaller ships, if agreed with the *Register*, such piping may be led to one side only. The pipeline shall end with the standard flange (see Fig. 2.5.2.1) where a hose can be easily connected to it. A name plate shall be fitted close to the flange. The flange shall be closed by a valve or a blank flange.

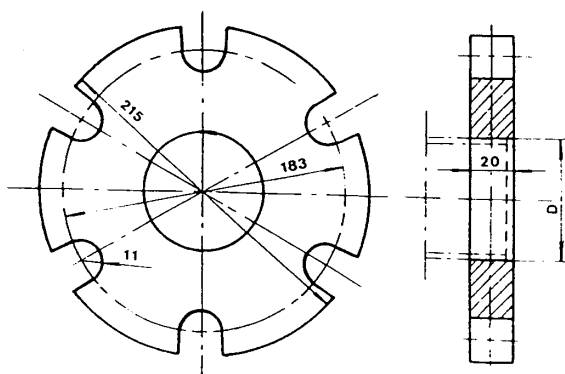

Figure 2.5.2.1
Standard flange of discharge connection

The flange is designed to accept pipes up to a maximum internal diameter of 125 mm and shall be of steel or other equivalent material having a flat face. This flange, together with a gasket of oil-proof material, shall be suitable for a service pressure of 0.6 MPa. Fastening bolts to be M20.

2.5.2.2 In the place of the standard flange connection, drip trays or similar devices shall be provided with the drainage piping in accordance with the requirements of the *Rules for the classification of ships, Part 8 - Piping*, Section 8.5. This requirement shall not apply to ships with gross tonnage less than 500 navigating in area 5 to 8.

2.5.2.3 All ships with an aggregate oil fuel capacity of 600 m³ and above which are delivered on or after 1st August 2010, are to comply with the following provisions:

- .1 Lines of oil fuel piping located at a distance from the ship's bottom of less than h or from the ship's side less than w (see MARPOL 73/78, Annex I, Regulation 12A) shall be fitted with valves or similar

closing devices within or immediately adjacent to the oil fuel tank.

These valves shall be capable of being brought into operation from a readily accessible enclosed space the location of which is accessible from the navigation bridge or propulsion machinery control position without traversing exposed freeboard or superstructure decks. The valves shall close in case of remote control system failure (fail in a closed position) and shall be kept closed at sea at any time when the tank contains oil fuel except that they may be opened during oil fuel transfer operations.

- .2 Suction wells in oil fuel tanks may protrude into the double bottom below the boundary line defined by the distance h provided that such wells are as small as practicable and the distance between the well bottom and the bottom shell plating is not less than 0,5 h.

2.6 TANKS FOR OIL RESIDUES (SLUDGE) AND OILY-WATER (BILGE) OF A MACHINERY SPACE

2.6.1 Definitions

2.6.1.1 Oil residue (sludge) – residual waste oil products such as those resulting from the purification of fuel or lubricating oil from main or auxiliary machinery or separated waste oil from bilge water separators, oil filtering equipment or oil collected in drip trays, and waste hydraulic and lubricating oils.

2.6.1.2 Oil residue (sludge) tanks – tanks which hold oil residue (sludge) directly from which oil residue (sludge) may be disposed through the standard discharge connection or any other approved means of disposal.

2.6.1.3 Oily bilge water – leaked water and oil from the equipment and piping or maintenance works in machinery space of ships, collected on the tank top or bilge wells.

2.6.1.4 Oily bilge water holding tanks – tanks collecting oily bilge water prior to its discharge overboard through 15 ppm bilge separator, transfer or disposal into reception facilities.

2.6.1.5 Oil residue (sludge) incineration systems – systems providing incineration of oil residue (sludge) generated on board seagoing ships. Oil residue (sludge) incineration systems could be:

- .1 main and auxiliary steam boilers with appropriate oil residue (sludge) processing systems;
- .2 heaters of thermal fluid systems with appropriate oil residue (sludge) processing systems;
- .3 incinerators with appropriate oil residue (sludge) processing systems; or
- .4 inert gas systems with appropriate oil residue (sludge) processing systems.

The oil sludge processing system consists of:

- a) oil residue (sludge) service tank;
- b) oil residue (sludge) preheating system;
- c) filter; and
- d) homogenization system.

2.6.1.6 Oil residue (sludge) drain tanks –

- .1 tanks intended to receive separated sludge from purifiers and other oil residue (sludge) drains;
- .2 tanks with suction connection for a sludge collecting pump only capable of discharging to the oil residue (sludge) tanks, without any means for disposal of sludge and drains through the standard discharge connection or in oil residue incineration system.

2.6.1.7 Sludge collecting pumps – pumps capable of taking suction from any oil residue (sludge) producing equipment or tank, other than an oil residue (sludge) tanks, and discharging only to oil residue (sludge) tanks.

2.6.1.8 Oil residue (sludge) service tank – tank for disposal of the oil residue (sludge) in the oil residue (sludge) incineration system.

2.6.2 General

2.6.2.1 Every ship of gross tonnage 400 tons and above shall be provided with a tank or tanks of adequate capacity, having regard to the type of machinery and length of voyage, to receive the oil residues (sludge) which cannot be dealt with otherwise in accordance with the requirements of this Section, such as those resulting from the purification of fuel and lubricating oils and oil leakage in the machinery spaces.

2.6.2.2 In ships delivered after 31st December 1979, such tanks shall be designed and constructed so as to facilitate their cleaning and the discharge of residues to reception facilities (see 2.6.5.2). Ships delivered on or before 31st December 1979 shall comply with this requirement as far as is reasonable and practicable.

2.6.2.3 Piping to and from sludge tanks shall have no direct connection overboard, other than the standard discharge connection referred to in 2.5. Ships having this piping to overboard discharge outlets may comply with this item by the installation of blanks in this piping.

2.6.2.4 Discharge pipeline from oily residue (sludge) tanks shall not be connected to any system other than oil residue incineration systems, auxiliary boiler suitable for burning oil residues (sludge) or other acceptable means.

2.6.2.5 For ships less than gross tonnage 400 tons, the *Register* shall specially determine a case for each ship (see 2.6.4).

2.6.3 Tanks for oil residues (sludge)

2.6.3.1 Minimum sludge tank capacity for a ship the keel of which is laid before 31st December 1990:

- .1 For ships which do not carry ballast water in oil fuel tanks, should be calculated by the following formula:

$$V_1 = K_1 \cdot C \cdot D \quad [\text{m}^3]$$

where:

$K_1 = 0,01$ for ships where heavy fuel oil is purified for main engine use,
 $= 0,005$ for ships using diesel oil or heavy fuel oil which does not require purification before use,

C – daily fuel oil consumption [t/day],

D – maximum period of voyage between ports where sludge can be discharged ashore [days]. In the absence of precise data a figure of 30 days should be used.

- .2 When such ships are fitted with homogenises, sludge incinerators or other recognised means on board for the control of sludge, the minimum sludge tank capacity (V_1) should, in lieu of the above, be:

$V_1 = 1 \text{ m}^3$ for ships of gross tonnage 400 tons and above but less than gross tonnage 4,000 tons,

$= 2 \text{ m}^3$ for ships of gross tonnage 4,000 tons and above.

- .3 For ships which carry ballast water in fuel oil tanks, the minimum sludge tank capacity (V_2) should be calculated by the following formula:

$$V_2 = V_1 + K_2 \cdot B \quad [\text{m}^3]$$

where:

V_1 – sludge tank capacity specified in 2.6.3.1.1 or 2.6.3.1.2, [m³],

$K_2 = 0,01$ for heavy fuel oil bunker tanks,

$= 0,005$ for diesel oil bunker tanks,

B – capacity of water ballast tanks which can also be used to carry oil fuel, [t].

2.6.3.2 Minimum sludge tank capacity for a ship the keel of which is laid on or after 31st December 1990:

- .1 For ships which do not carry ballast water in fuel oil tanks, should be calculated by the following formula:

$$V_1 = K_1 \cdot C \cdot D \quad [\text{m}^3]$$

where:

$K_1 = 0,015$ for ships where heavy fuel oil is purified for main engine use,
 $= 0,005$ for ships using diesel oil or heavy fuel oil which does not require purification before use,

C – daily fuel oil consumption, [m³/day]

D – maximum period of voyage between ports where sludge can be discharged ashore [days]. In the absence of precise data a figure of 30 days should be used.

- .2 For ships fitted with homogenises, sludge incinerators or other recognised means on board for the control of sludge, the minimum sludge tank capacity should be:

1. 50% of the value calculated according to item 2.6.3.2.1; or
 2. 1 m³ for ships of gross tonnage 400 tons and above but less than gross tonnage 4000 tons, or
 3. 2 m³ for ships of gross tonnage 4000 tons and above;
- whichever is the greater.

2.6.3.3 The separated dirty water and exhausted control water of fuel oil purifiers should be discharged into a particular tank for this purpose, located above the double bottom for the purpose of facilitating its drain without the need of a drain pump. If dirty water and exhausted control water from purifiers is not discharged to a particular tank, in lieu of this it is to be discharged to an oil residue (sludge) drain tank for separated sludge.

2.6.3.4 Oil residue (sludge) drain tank shall be located below the heavy fuel oil purifier. If this is not possible, the oil residue (sludge) drain tank shall be situated close to the heavy fuel oil purifier in such a way that the discharge line to the tank can be installed at the maximum gradient. The pipelines from the purifier to the tank shall, wherever possible, be straight or fitted with large radius elbows.

2.6.4 Tanks for oily bilge water

2.6.4.1 The *Register* may permit for every ship of gross tonnage 400 tons and above and for every ship of gross tonnage less than 400 tons engaged in international voyages to be provided only with tanks to receive oily bilge water in the machinery spaces, if they are not equipped in accordance with 2.3 or 2.4, under following conditions:

- .1 Holding tank has adequate capacity to retain on board all quantity of bilge water;
- .2 Oily bilge water is retained on board for discharge to reception facilities;
- .3 The Administration has determined that adequate reception facilities are available to receive oily bilge water in sufficient number of ports or terminals the ship calls at;
- .4 International oil pollution prevention certificate, if required, is endorsed in such a way that the ship is engaged exclusively on the voyages within special areas or in Arctic waters, or the ship is certified under the HSC Code engaged on a scheduled service with a turn around time not exceeding 24 hours and covering also non passenger/cargo carrying relocation voyages for these ships;
- .5 Quantity, time and the port of discharge is recorded in the *Oil Record Book, Part 1*.

2.6.4.2 Every ship of less than gross tonnage 400 tons engaged in voyage within area of navigation 5-8, shall be provided with tanks for oily bilge water and with the necessary equipment for their discharge (pumps, piping) according to 2.6.4.1 or shall be provided with portable means (vessels, cans) as follows:

up to 50 gross tonnage 2 vessels of 25 litres
50-200 gross tonnage 4 vessels of 25 litres
200-400 gross tonnage 6 vessels of 25 litres

The vessels may be of steel or plastic and marked with *bilge* or *oily water* and shall be capable of being filled up by a manual bilge pump.

2.6.4.3 The discharge piping of the tanks for oily water (bilge) shall not be connected to bilge piping or other piping except to standard flange connection discharge pipeline.

2.6.4.4 Discharge piping of oily water tanks shall not be led directly to ship's side if the piping is not connected to the pipeline referred to in 2.5.2.

2.6.4.5 The recommended capacity of oily bilge water holding tanks is shown in Table 2.6.4.5.

Table 2.6.4.5
Recommended capacity of oily bilge water holding tanks

Main engine rating <i>P</i> [kW]	Capacity [m ³]
up to 1.000	4
above 1.000 up to 20.000	<i>P</i> /250
above 20.000	40+ <i>P</i> /500

For ships within area of navigation 5-8 and for yachts with length more than 24m within area of navigation III and IV minimum oily bilge water tank capacity is to be as follows:

Table 2.6.4.5a

Gross tonnage	Minimum tank capacity
400 GT to 500 GT	250 l
500 GT to 700 GT	500 l
700 GT to 1000 GT	750 l
1000 GT to 1600 GT	1500 l

For yachts with length more than 24 m engaged in international voyages minimum oily bilge water tank capacity is to be as follows:

Table 2.6.4.5b

Gross tonnage	Minimum tank capacity
up to 300 GT – short range yacht	150 l
up to 400 GT	200 l
400 GT to 500 GT	400 l
500 GT to 700 GT	1000 l
700 GT to 1000 GT	1500 l
1000 GT to 1600 GT	3000 l
1600 GT and over	according to table 2.6.4.5

2.6.5 Arrangement of oil residue (sludge) tanks and of oily-water (bilge) tanks

2.6.5.1 Tanks may be structural or non-structural. Structural tanks shall meet the requirements of the *Rules for the classification of ships, Part 2 - Hull*.

Oily bilge water holding tanks are to be separate and independent from other tanks for the collection of oil residue (sludge).

For ships not equipped with bilge separator or fuel or lubricating oil separators, oily bilge water and oil residue (sludge) may be collected in a common holding tank.

2.6.5.2 The design and construction of oil residue (sludge) tanks to facilitate their cleaning and the discharge of residues to reception facilities, on ships the keel of which is laid or which are at a similar stage of construction on or after 31st December 1990, is to comply with the following:

- .1 sufficient manholes should be provided such that, taking into consideration the internal structure of the sludge tanks, all parts of the tank can be reached to facilitate cleaning. The oil residue (sludge) tanks should be fitted with steaming-out lines for cleaning;
- .2 sludge tanks in ships operating with heavy oil, that needs to be purified for use, should be fitted with adequate sludge heating arrangements up to 60°C or other suitable means to facilitate the pumpability and discharge of the tank content. The suction line from the sludge tanks to the pump shall be provided, where necessary, with heat tracing. Oily bilge water tanks in ships operating with heavy oil should be fitted, where necessary, with heating arrangements to preheat the oily water before discharge;
- .3 oil residue (sludge) tanks shall have no discharge connections to the bilge system, oily bilge water holding tanks, tank top or oily water separators;
- .4 there shall be no interconnections between the oil residue (sludge) tank discharge piping and bilge-water piping other than possible common piping leading to the standard discharge connection referred to in 2.5.2. The connection of both systems to the common piping shall not allow for the transfer of sludge to the bilge system. A screw-down non-return valve arranged in lines connecting to common piping provides an acceptable means to prevent sludge from being transferred to the bilge system. However, arrangements may be made for draining of settled water from the oil residue (sludge) tanks by means of manually operated self-closing valves and arrangements for subsequent visual monitoring of the settled water, or equivalent arrangements. Drain is to lead to an oily bilge water holding tank or to a bilge well;
- .5 the oil residue (sludge) tank and the oily-water (bilge) tank shall be provided with a

designated pump for the discharge of the tank content to reception facilities or to any other approved means of disposal of sludge. The pump should be of a suitable type, capacity and discharge head, having regard to the characteristics of the liquid being pumped and the size and position of tank(s) and the overall discharge time (4 to 8 hours), with suitable means for protection against dry running.

- .6 tanks shall be provided with air pipe.
- .7 tanks shall be provided with visual and audio alarm for high level in the tank. This requirement shall not apply to ships with gross tonnage less than 500 navigating in area 5 to 8, provided that tanks are equipped with sounding arrangements in accordance with *Rules for the classification of ships, Part 8 - Piping, Item 5.5*.

Ships constructed before 1st January 2017 shall comply with 2.6.5.2.3 and 2.6.5.2.4 not later than the first renewal survey carried out on or after 1st January 2017.

2.6.5.3 Inside surface of bottom and walls shall be smooth and the tank bottom shall incline towards the suction pipe.

The openings shall be placed as wide as possible in the frames above the tank bottom in such a way that the oil sludge has free access to the suction line.

2.6.5.4 The oil residue (sludge) service tank should be equipped with suitable means for drainage of water in accordance with 2.6.5.2.4 and a fuel oil supply connection with a view to improving combustibility and calorific value. Water in oil residues (sludge) may be evaporated by heating the sludge in service tank.

2.6.5.5 The homogenization system shall assure that the entire contents of the oil residue (sludge) service tank shall be processed into a homogenous and combustible mixture. A device for continuous indication and monitoring of the water content of the oil sludge should be provided.

2.6.5.6 Where oil residue (sludge) service tank is equipped with suitable means for drainage, the requirements in 2.6.5.2.5 need not be applied.

2.7 SPECIAL REQUIREMENTS FOR FIXED OR FLOATING PLATFORMS

2.7.1 Fixed or floating platforms when engaged in the exploration, exploitation and associated offshore processing of sea-bed mineral resources and other platforms shall comply with the requirements of this *Rules* applicable to ships of 400 gross tonnage and above other than oil tankers.

2.7.2 Fixed or floating platforms shall be equipped as far as practicable with the installations required in 2.3, 2.4 and 2.6, and shall keep a record of all operations involving oil or oily mixture discharges in a form approved by the *Register*.

2.7.3 Only the discharges of machinery space drainage and contaminated ballast are subject to MARPOL 73/78. Offshore processing drainage and production water discharge are subject to national regulations.

2.7.4 In verifying compliance with this Rules in relation to floating production, storage and offloading facilities (FPSO) and floating storage units (FSU), account should be taken of the Guidelines for the application of MARPOL Annex I requirements to FPSO and FSU, according to IMO Res. MEPC.311(73).

2.8 SHIPBOARD OIL POLLUTION EMERGENCY PLAN

2.8.1 Every oil tanker of 150 tons gross tonnage and above and every ship other than an oil tanker of 400 tons gross tonnage and above shall carry on board a *Shipboard oil pollution emergency plan* approved by the Register.

2.8.2 Such a plan shall be in accordance with guidelines developed by the Organisation* and written in the working language of the master and officers. The plan shall consist at least of:

- .1 the procedure to be followed by the master or other persons having charge of the ship to report an oil pollution incident, as required in article 8 and Protocol I of the Convention MARPOL 73/78, based on the guidelines developed by the Organisation**;
- .2 the list of authorities or persons to be contacted in the event of an oil pollution incident;
- .3 a detailed description of the action to be taken immediately by persons on board to reduce or control the discharge of oil following the incident; and
- .4 the procedures and point of contact on the ship for co-ordinating shipboard action with national and local authorities in combating the pollution.

2.8.3 All oil tankers of 5,000 tons dead-weight or more shall have prompt access to the computerised, shore-based damage stability and residual structural strength calculation programs.

2.8.4 Any fixed or floating platform or other offshore installation when engaged in the exploration, exploitation and associated offshore processing of sea-bed mineral resources, which has an oil pollution emergency plan coordinated with and approved in accordance with procedures established by the coastal State, should be regarded as complying with 2.8.1 and 2.8.2.

* Reference is made to *Guidelines for the development of shipboard oil pollution emergency plans* adopted by the Organisation by IMO Res. MEPC.54(32) and IMO Res. MEPC.86(44).

** Reference is made to *General Principles for Ship Reporting Systems and Ship Reporting Requirements, including Guidelines for Reporting Incidents Involving Dangerous Goods, Harmful Substances and/or Marine Pollutants* adopted by the Organisation by resolution A.851(20), as amended by IMO Res. MEPC.138(53).

2.9 STS OPERATIONS PLAN

2.9.1 Any oil tanker of 150 gross tonnage and above involved in transfer of oil cargo between oil tankers at sea (STS operations) shall carry onboard a Plan prescribing how to conduct STS operations (STS operations plan) not later than the date of the first annual, intermediate or renewal survey of the ship to be carried out on or after 1 January 2011.

The STS operations plan shall be written in the working language of the ship and shall be approved by the Register.

2.9.2 STS operations plan shall be developed taking into account the information contained in IMO Manual on oil pollution, Section I, Prevention, as amended and in ICS/OCIMF Ship to ship transfer guide, Petroleum, last edition.

2.9.3 The person in overall advisory control of STS operations shall be qualified to perform all relevant duties.

2.9.4 Records of STS operations in the Oil record book shall be retained onboard for three years and be readily available for inspection by a Party to the Convention.

2.9.5 Item 2.9 shall not apply to oil transfer operations associated with fixed or floating platforms (see item 2.7).

Item 2.9 shall not apply to bunkering operations and to STS operations necessary for the purpose of securing the safety of a ship or for combating pollution incidents.

2.10 UNMANNED NON-SELF-PROPELLED BARGES

2.10.1 The Administration may exempt an unmanned non-self-propelled (UNSP) barge from the certain survey and certification requirements of Annex I by means of an International Oil Pollution Prevention Exemption Certificate for Unmanned Non-self-propelled (UNSP) Barges, for a period not exceeding five years provided that the barge has undergone a survey to confirm that conditions referred to in 2.1.2.45 of this Section are met.

Guidelines for the exemption of unmanned non-self-propelled barges from certain survey and certification requirements under the MARPOL Convention are given in MEPC.1/Circ.892. In addition to requirements stated in MEPC.1/Circ.892, specific requirements of the Administration should also be followed, if any.

2.10.2 In accordance with 2.10.1, the International Oil Pollution Prevention Exemption Certificate for Unmanned Non-self-propelled Barges shall be drawn up in the form corresponding to the model given in appendix IV of Annex I of MEPC.330(76) and shall be at least in English, French or Spanish. If an official language of the issuing country is also used, this shall prevail in the event of a dispute or discrepancy.

3 PREVENTION OF POLLUTION BY NOXIOUS LIQUID SUBSTANCES IN BULK

3.1 GENERAL

3.1.1 Application

3.1.1.1 The present part of the Rules apply to the construction, equipment, installation and systems of the ships, intended to prevent pollution by noxious liquid substances.

MARPOL 73/78, Annex II, entered into force on 2nd October 1983.

Regarding amendments to MARPOL Annex II related to the categorisation of noxious liquid substances refer to IMO Res. MEPC.344(78).

3.1.1.2 Unless expressly provided otherwise, the requirements of this Section apply to all ships which are intended to carry noxious liquid substances in bulk.

3.1.1.3 Where a cargo subject to the provisions of Annex I of MARPOL 73/78 is carried in a cargo space of an NLS tanker, the appropriate requirements of Section 2 shall also apply.

3.1.1.4 The building in of the equipment, installations, materials and instruments other than those required in this Section of the *Rules* shall be permitted only if agreed with the *Register*.

3.1.1.5 The *Register* may exempt ships from the carriage requirements in 3.2.1 for ships certified to carry individually identified vegetable oils in chapter 17 of the IBC Code, provided the ship complies with the following conditions:

- .1 NLS tanker shall meet all requirements for ship type 3 as identified in the IBC Code except for cargo tank location;
- .2 cargo tanks shall be located at the following distances inboard. The entire cargo tank length shall be protected by ballast tanks or spaces other than tanks that carry oil as follows:
 - .1 wing tanks or spaces shall be arranged such that cargo tanks are located inboard of the moulded line of the side shell plating nowhere less than 760 mm;
 - .2 double bottom tanks or spaces shall be arranged such that the distance between the bottom of the cargo tanks and the moulded line of the bottom shell plating measured at right angles to the bottom shell plating is not less than $B/15$ (m) or 2,0 m at the centreline, whichever is the lesser. The minimum distance shall be 1,0 meter; and
 - .3 the relevant certificate shall indicate the exemption granted.

3.1.1.6 The provisions of 3.3.4.2 need not apply to a ship constructed before 1st July 1986 which is engaged in restricted voyages as determined by the Administration between ports or terminals within a State Party /of States Parties to the present Convention if:

- .1 each time a tank containing Category X, Y or Z substances or mixtures is to be washed or ballasted, the tank is washed in accordance with a pre-wash procedure approved by the *Register* in compliance with 3.3.2, and the tank washings are discharged to a reception facility;
- .2 subsequent washings or ballast water are discharged to a reception facility or at sea in accordance with other provisions of this Section;
- .3 the adequacy of the reception facilities at the ports or terminals referred to above, for the purpose of this paragraph, is approved by the Governments of the States Parties to the present Convention within which such ports or terminals are situated; and
- .4 the certificate required under this Section is endorsed to the effect that the ship is solely engaged in such restricted voyages.

3.1.1.7 For a ship whose constructional and operational features are such that ballasting of cargo tanks is not required and cargo tank washing is only required for repair or dry-docking, the Administration may allow exemption from the provisions of 3.2.2, 3.3.4, 3.3.6 and 3.3.7, provided that all of the following conditions are complied with:

- .1 the design, construction and equipment of the ship are approved by the *Register*, having regard to the service for which it is intended;
- .2 any effluent from tank washings which may be carried out before a repair or dry-docking is discharged to a reception facility, the adequacy of which is ascertained by the Administration;
- .3 the certificate required under this Section indicates:
 - .1 that each cargo tank is certified for the carriage of a restricted number of substances which are comparable and can be carried alternately in the same tank without intermediate cleaning; and
 - .2 the particulars of the exemption;
- .4 the ship carries a Manual approved by the *Register*.

3.1.1.8 The construction and equipment of liquefied gas carriers certified to carry Noxious Liquid Substances listed in the applicable Gas Carrier Code, shall be deemed to be equivalent to the construction and equipment requirements contained in 3.2, 3.3.4, 3.3.6 and 3.3.7, provided that the gas carrier meets all following conditions:

- .1 hold a Certificate of Fitness in accordance with the appropriate Gas Carrier Code for ships certified to carry liquefied gases in bulk;
- .2 hold an International Pollution Prevention Certificate for the Carriage of Noxious Liquid Substances in Bulk, in which it is

- certified that the gas carrier may carry only those Noxious Liquid Substances identified and listed in the appropriate Gas Carrier Code;
- .3 be provided with segregated ballast arrangements;
 - .4 be provided with pumping and piping arrangements, which, to the satisfaction of the *Register*, ensure that the quantity of cargo residue remaining in the tank and its associated piping after unloading does not exceed the applicable quantity of residue as required by 3.3.4.2, 3.3.4.3 or 3.3.4.4; and
 - .5 be provided with a Manual, approved by the *Register*, ensuring that no operational mixing of cargo residues and water will occur and that no cargo residues will remain in the tank after applying the ventilation procedures prescribed in the Manual.

3.1.2 Definitions

The explanation of terms and expressions, used in all Sections, is specified in Section 1 - General. The following terms and expressions are applied in the present Section:

3.1.2.1 Chemical tanker – means a ship constructed or adapted for the carriage in bulk of any liquid product listed in chapter 17 of the International Bulk Chemical Code.

3.1.2.2 NLS tanker – means a ship constructed or adapted to carry a cargo of Noxious Liquid Substances in bulk and includes an oil tanker as defined in 2.1.2.5 when certified to carry a cargo or part cargo of Noxious Liquid Substances in bulk.

3.1.2.3 Ship constructed – means a ship the keel of which is laid or which is at a similar stage of construction. A ship converted to a chemical tanker, irrespective of the date of construction, shall be treated as a chemical tanker constructed on the date on which such conversion commenced. This conversion provision shall not apply to the modification of a ship which complies with all of the following conditions:

- .1 the ship is constructed before 1st July 1986; and
- .2 the ship is certified under the Bulk Chemical Code to carry only those products identified by the Code as substances with pollution hazards only.

3.1.2.4 Similar stage of construction – means the stage at which:

- .1 construction identifiable with a specific ship begins; and
- .2 assembly of that ship has commenced comprising at least 50 tons or one percent of the estimated mass of all structural material, whichever is less.

3.1.2.5 Associated piping – means the pipeline from the suction point in a cargo tank to the shore connection used for unloading the cargo and includes all ship's piping, pumps and filters which are in open connection with the cargo unloading line.

3.1.2.6 Clean ballast – means ballast carried in a tank which, since it was last used to carry a cargo containing a substance in Category X, Y or Z, has been thoroughly cleaned and the residues resulting therefrom have been discharged and the tank emptied in accordance with the appropriate requirements of this Section.

3.1.2.7 Segregated ballast – see 2.1.2.21.

3.1.2.8 Liquid substances – are those having a vapour pressure not exceeding 0,28 MPa absolute at a temperature of 37,8°C.

3.1.2.9 Noxious liquid substance - means any substance indicated in the pollution category column of chapter 17 or 18 in IBC Code or in the *Rules for the classification of ships, Part 27 - Chemical Tankers*, Table 17.1.1-1 or 18.1.1-1, or provisionally assessed under the provisions of 3.1.2.9.5 as falling into Category X, Y or Z.

- .1 **Category X** – Noxious liquid substances which, if discharged into the sea from tank cleaning or de-ballasting operations, would present a major hazard to either marine resources or human health and, therefore, justify the prohibition of the discharge into the marine environment.
- .2 **Category Y** – Noxious liquid substances which, if discharged into the sea from tank cleaning or de-ballasting operations, would present a hazard to either marine resources or human health or cause harm to amenities or other legitimate uses of the sea and, therefore, justify the limitation on the quality and quantity of the discharge into the marine environment.
- .3 **Category Z** – Noxious liquid substances which, if discharged into the sea from tank cleaning or de-ballasting operations, would present a minor hazard to either marine resources or human health and, therefore, justify less stringent restrictions on the quality and quantity of the discharge into the marine environment.
- .4 **Other Substances** – substances indicated as OS (Other Substances) in the pollution category column of chapter 18 of the International Bulk Chemical Code which have been evaluated and found to fall outside Category X, Y or Z because they are, at present, considered to present no harm to marine resources, human health, amenities or other legitimate uses of the sea when discharged into the sea from tank cleaning or de-ballasting operations. The discharge of bilge or ballast water or other residues or mixtures containing only substances referred to as Other Substances shall not be subject to any requirements of this Section.
- .5 Where it is proposed to carry a liquid substance in bulk which has not been categorised, the Governments of Parties to the Convention involved in the proposed operation shall establish and agree on a provisional assessment for the proposed operation on the basis of the guidelines for the

categorisation of noxious liquid substances, MEPC/Circ.265 as amended. Until full agreement among the Governments involved has been reached, the substance shall not be carried.

3.1.2.10 Solidifying substance – means a noxious liquid substance which:

- .1 in the case of a substance with melting point of less than 15°C which is at a temperature, at the time of unloading, of less than 5°C above its melting point; or
- .2 in the case of a substance with melting point of equal to or greater than 15°C which is at a temperature, at the time of unloading, of less than 10°C above its melting point.

3.1.2.11 Non-solidifying substance – means a noxious liquid substance which is not a solidifying substance.

3.1.2.12 High-viscosity substance – means a noxious liquid substance in Category X or Y with a viscosity equal to or greater than 50 mPa.s at the unloading temperature.

3.1.2.13 Low-viscosity substance – means a noxious liquid substance which is not a high-viscosity substance.

3.1.2.14 Residue – means any noxious liquid substance which remains for disposal.

3.1.2.15 Residue/water mixture – means residue to which water has been added for any purpose (e.g. tank cleaning, ballasting, bilge slops).

3.1.2.16 ppm – means ml/m³.

3.1.2.17 IBC CODE (International Bulk Chemical Code) – means the International Code for the Construction and Equipment of Ships Carrying Dangerous Chemicals in Bulk.

3.1.2.18 BCH CODE (Bulk Chemical Code) – means the Code for the Construction and Equipment of Ships Carrying Dangerous Chemicals in Bulk.

3.1.2.19 Manual – means Procedures and Arrangements Manual in accordance with 3.1.6.

3.1.2.20 Depth of water – means the charted depth.

3.1.2.21 En route – means that the ship is under way at sea on a course or courses, including deviation from the shortest direct route, which as far as practicable for navigational purposes, will cause any discharge to be spread over as great an area of the sea as is reasonable and practicable.

3.1.2.22 Nearest land – see 2.1.2.33.

3.1.2.23 Persistent floater – means a slick forming substance with the following properties:

- Density: \leq sea water (1025 kg/m³ at 20°C);
- Vapour pressure: \leq 0.3 kPa;
- Solubility: \leq 0.1 % (for liquids) \leq 10% (for solids); and
- Kinematic viscosity: $>$ 10 cSt at 20°C.

3.1.3 Scope of supervision

3.1.3.1 Intentionally blank.

3.1.3.2 Supervision during construction shall cover:

- .1 Ventilation system
- .2 Tank washing system
- .3 Residue discharge system

3.1.3.3 Technical documentation which shall be submitted to the *Register* for approval for the systems referred to in 3.1.3.2:

- .1 Technical description, method of work with technical data and instruction for operation and maintenance;
- .2 General plan with cross sections;
- .3 List of materials and component parts;
- .4 General and functional scheme, as appropriate;
- .5 Scheme of the control, signalling and protection, as appropriate;
- .6 Electrical scheme, as appropriate;
- .7 Drawings of assemblies and component parts of the system, as appropriate;
- .8 Testing program.

If found necessary, the *Register* may require additional technical documentation, data on safety of the equipment and arrangements (installations) as well as the documentation in accordance with the *Rules for the classification of ships, Part 27 - Chemical tankers*.

3.1.4 Workshop testing

3.1.4.1 Equipment, installations, systems and instruments after being assembled shall be tested according to the program referred to in 3.1.3.3-8 approved by the *Register*.

In particular cases, the *Register* may permit the testing to be carried out onboard ship instead of testing on test bench.

3.1.5 General requirements

3.1.5.1 Materials intended for the manufacture of equipment, installations and systems shall comply with the requirements of the *Rules for the classification of ships, Part 25 - Metallic materials*.

3.1.5.2 Electrical equipment of the machines and the equipment shall meet the requirements of the *Rules for the classification of ships, Part 12 - Electrical equipment*.

3.1.5.3 Pipeline systems, pipes and fittings shall meet the requirements of the *Rules for the classification of ships, Part 8 - Piping*.

3.1.6 Procedures and Arrangements Manual

3.1.6.1 Every ship certified to carry substances of Category X, Y or Z shall have on board a Manual approved by the *Register*. The Manual shall have a standard format in compliance with appendix 4 to MARPOL 73/78, Annex II. In the case of a ship engaged in international voyages on which the language used is not English, French or Spanish, the text shall include a translation into one of these languages.

3.1.6.2 The main purpose of the Manual is to identify for the ship's officers the physical arrangements and all the operational procedures with respect to cargo handling, tank cleaning, slops handling and cargo tank ballasting and de-ballasting which must be followed in order to comply with the requirements of MARPOL 73/78, Annex II.

3.1.7 Cargo record book

Every ship to which this part of the Rules applies shall be provided with a Cargo Record Book, whether as a part of the ship's official logbook, as an electronic record book which shall be approved by the Administration taking into account Guidelines in Resolution MEPC.312(74), or otherwise, in the form specified in appendix II to MARPOL 73/78, Annex II.

3.2 CHEMICAL TANKER CONSTRUCTION

3.2.1 General requirements

3.2.1.1 Chemical tankers shall be constructed in a compliance with the requirements of the *Rules for the classification of ships, Part 27 - Chemical tankers*.

3.2.1.2 The design, construction, equipment and operation of ships carrying noxious liquid substances, identified in chapter 17 of IBC Code, in bulk, shall be in compliance with the following provisions, to minimise the uncontrolled discharge into the sea of such substances:

- .1 the International Bulk Chemical Code when the chemical tanker is constructed on or after 1st July 1986; or
- .2 the Bulk Chemical Code as referred to in paragraph 1.7.2 of that Code for:
 - .1 ships for which the building contract is placed on or after 2nd November 1973 but constructed before 1st July 1986, and which are engaged on voyages to ports or terminals under the jurisdiction of other States Parties to the Convention; and
 - .2 ships constructed on or after 1st July 1983 but before 1st July 1986, which are engaged solely on voyages between ports or terminals within the State the flag of which the ship is entitled to fly.
- .3 the Bulk Chemical Code as referred to in paragraph 1.7.3 of that Code for:
 - .1 ships for which the building contract is placed before 2nd November 1973 and which are engaged on voyages to ports or terminals under the jurisdiction of other States Parties to the Convention; and
 - .2 ships constructed before 1st July 1983, which are solely engaged on voyages between ports or terminals within the State the flag of which the ship is entitled to fly.

3.2.1.3 In respect of ships other than chemical tankers or liquefied gas carriers certified to carry Noxious Liquid Substances in bulk identified in chapter 17 of the International Bulk Chemical Code, the Administration shall establish appropriate measures based on the Guidelines developed by the Organisation (reference is made to resolution A.673(16), as amended by IMO Res. MEPC.158(55) and IMO Res. MEPC.148(54)) in order to ensure that the provisions shall be such as to minimise the uncontrolled discharge into the sea of such substances.

3.2.2 Slop tanks

3.2.2.1 Slop tanks may be needed for certain washing procedures. Slop tanks shall meet the following requirements:

- .1 Minimum capacity of slop tanks shall be specified with respect to navigational conditions of a tanker. Cargo tanks may be used as slop tanks.
- .2 The number of slop tanks shall be determined with respect to the liability of decomposition of the different cargo residues which are carried simultaneously.
- .3 Pumps, piping and ventilation serving slop tanks shall be separated from similar arrangements which are used for tanks with cargo which may be hazardous in contact with water.

3.3 EQUIPMENT FOR PREVENTION OF POLLUTION

3.3.1 Equipment of ventilation system

3.3.1.1 The ventilation system shall comply with the requirements of *Rules for the classification of ships, Part 27 - Chemical tankers*, Section 6.

3.3.1.2 Cargo residues of substances with a vapour pressure greater than 5000 Pa at 20°C may be removed from a cargo tank by ventilation.

3.3.1.3 The pipelines shall be drained and further cleared of liquid by means of ventilation equipment.

3.3.1.4 The list and trim shall be adjusted to the minimum levels possible so that evaporation of residues in the tank is enhanced.

3.3.1.5 Ventilation equipment producing an air jet which can reach the tank bottom shall be used. Figure 3.3.1.5 could be used to evaluate the adequacy of ventilation equipment used for ventilating a tank of a given depth.

3.3.1.6 Ventilation equipment shall be placed in the tank opening closest to the tank sump or suction point.

3.3.1.7 Ventilation equipment shall, when practicable, be positioned so that the air jet is directed at the tank sump or suction point and impingement of the air jet on tank structural members is to be avoided as much as possible.

3.3.1.8 Ventilation shall continue until no visible remains of liquid can be observed in the tank. This shall be verified by a visual examination or an equivalent method.

3.3.2 Equipment of cargo tank washing system (for ships built on or after 1st July 1994)

3.3.2.1 For ship built before 1st July 1994, see MARPOL 73/78, Annex II, Appendix 6, Chapter A.

3.3.2.2 The equipment of cargo tank washing system shall comply with the requirements of MARPOL 73/78, Annex II and can be designed and installed as the oil tanker washing equipment according to 2.2.1, with difference in a material and a procedure.

3.3.2.3 The equipment and procedures include pre-wash and wash of cargo tanks and slop tanks, for non-solidifying and solidifying noxious substances.

3.3.2.4 Non-solidifying noxious substances washing equipment without recycling:

- .1 Tanks should be washed by means of a rotary water jet, operated at sufficiently high water pressure. In the case of Category X substances washing machines should be operated in such locations that all tank surfaces are washed. In the case of Category Y substances only one location need be used.
- .2 During washing the amount of liquid in the tank should be minimised by continuously pumping out slops and promoting flow to the suction point. If this condition cannot be met, the washing procedure should be repeated three times, with thorough stripping of the tank between washings.
- .3 Those substances which have a viscosity equal to or greater than 50 mPa.s at 20°C should be washed with hot water (temperature at least 60°C), unless the properties of such substances make the washing less effective.
- .4 The quantities of wash water used shall not be less than those specified in 3.3.2.7-.1 or determined according to 3.3.2.7-.2.
- .5 After pre-washing the tanks and lines shall be thoroughly stripped.

3.3.2.5 Solidifying noxious substances washing equipment without recycling:

- .1 Tanks should be washed as soon as possible after unloading. If possible, tanks should be heated prior to washing.
- .2 Residues in hatches and manholes should preferably be removed prior to the pre-wash.
- .3 Tanks should be washed by means of a rotary water jet operated at sufficiently high water pressure and in locations to ensure that all tank surfaces are washed.
- .4 During washing the amount of liquid in the tank shall be minimised by pumping out slops continuously and promoting flow to the suction point. If this condition cannot be met, the washing procedure shall be repeated three times with thorough stripping of the tank between washings.

- .5 Tanks shall be washed with hot water (temperature at least 60°C), unless the properties of such substances make the washing less effective.
- .6 The quantities of wash water used shall not be less than those specified in 3.3.2.7-.1 or determined according to 3.3.2.7-.2.
- .7 After pre-washing the tanks and lines shall be thoroughly stripped.

3.3.2.6 medium:

Pre-wash procedures with recycling of washing

- .1 Washing with a recycled washing medium may be adopted for the purpose of washing more than one cargo tank. In determining the quantity, due regard must be given to the expected amount of residues in the tanks and the properties of the washing medium and whether any initial rinse or flushing is employed. Unless sufficient data are provided, the calculated end concentration of cargo residues in the washing medium shall not exceed 5% based on nominal stripping quantities.
- .2 The recycled washing medium shall only be used for washing tanks having contained the same or similar substance.
- .3 A quantity of washing medium sufficient to allow continuous washing shall be added to the tank or tanks to be washed.
- .4 All tank surfaces shall be washed by means of a rotary jet(s) operated at sufficiently high pressure. The recycling of the washing medium may either be within the tank to be washed or via another tank, e.g. a slop tank.
- .5 The washing shall be continued until the accumulated throughput is not less than that corresponding to the relevant quantities given in 3.3.2.7-.1 or determined according to 3.3.2.7-.2.
- .6 Solidifying substances and substances with viscosity equal to or greater than 50 mPa.s at 20°C shall be washed with hot water (temperature at least 60°C) when water is used as the washing medium, unless the properties of such substances make the washing less effective.
- .7 After completing the tank washing with recycling to the extent specified in paragraph 5, the washing medium shall be discharged and the tank thoroughly stripped. Thereafter, the tank shall be subjected to a rinse, using clean washing medium, with continuous drainage and discharged to a reception facility. The rinse shall as a minimum cover the tank bottom and be sufficient to flush the pipelines, pump and filter.

3.3.2.7 wash:

Minimum quantity of water to be used in a pre-wash:

- .1 The minimum quantity of water to be used in a pre-wash is determined by the residual quantity of noxious liquid substance in the tank, the tank size, the cargo properties,

the permitted concentration in any subsequent wash water effluent, and the area of operation. The minimum quantity is given by the following formula:

$$Q = k (15r^{0.8} + 5r^{0.7} \cdot V/1000)$$

where:

Q – the required minimum quantity, [m³]

r – the residual quantity per tank, [m³].

The value of r shall be the value demonstrated in the actual stripping efficiency test, but shall not be taken lower than 0,100 m³ for a tank volume of 500 m³ and above and 0,040 m³ for a tank volume of 100 m³ and below. For tank sizes between 100 m³ and 500 m³ the minimum value of r allowed to be used in the calculations is obtained by linear interpolation.

For Category X substances the value of r shall either be determined based on stripping tests according to the Manual, observing the lower limits as given above, or be taken to be 0.9 m³.

V – tank volume, [m³]

k – a factor having values as follows:
Category X, non-Solidifying, Low-Viscosity Substance, $k = 1.2$
Category X, Solidifying or High-Viscosity Substance, $k = 2.4$
Category Y, non-Solidifying, Low-Viscosity Substance, $k = 0.5$
Category Y, Solidifying or High-Viscosity Substance, $k = 1.0$

- .2 Verification testing for approval of pre-wash volumes lower than those given in paragraph 3.3.2.7-1 may be carried out to the satisfaction of the *Register* to prove that the requirements of MARPOL 73/78, Annex II, Reg.13 are met, taking into account the substances the ship is certified to carry. The pre-wash volume so verified shall be adjusted for other pre-wash conditions by application of the factor k as defined in paragraph 3.3.2.7-1.

3.3.2.8 When a washing medium other than water, such as mineral oil or chlorinated solvent, is used instead of water to wash a tank, its discharge shall be governed by the provisions of either MARPOL 73/78, Annex I or MARPOL 73/78, Annex II, which would apply to the medium had it been carried as cargo. Tank washing procedures involving the use of such a medium shall be set out in the Manual and be approved by the *Register*.

3.3.2.9 When small amounts of cleaning additives (detergent products) are added to water in order to facilitate tank washing, no additives containing Pollution Category X components shall be used except those components that are readily biodegradable and present in a total concentration of less than 10% of the cleaning additive. No restrictions additional to those applicable to the tank due to the previous cargo shall apply.

3.3.2.10 Prewash procedures for persistent floaters to which the provision of 3.3.3.7.4 applies.

Persistent floaters with a viscosity equal to or greater than 50 mPa·s at 20°C and/or a melting point equal to or greater than 0°C, shall be treated as solidifying or high-viscosity substances for the purposes of the prewash. Where it is determined that the use of small amounts of cleaning additives would improve and maximize the removal of cargo residues during a prewash, then this should be done in consultation and with prior agreement from the reception facility.

3.3.3 Systems for the discharge of residues of noxious liquid substances

3.3.3.1 The discharge into the sea of residues of substances assigned to Category X, Y or Z or of those provisionally assessed as such or ballast water, tank washings or other mixtures containing such substances shall be prohibited unless such discharges are made in full compliance with the applicable operational requirements contained in MARPOL 73/78, Annex II.

3.3.3.2 Before any pre-wash or discharge procedure is carried out in accordance with this regulation, the relevant tank shall be emptied to the maximum extent in accordance with the procedures prescribed in the Manual.

3.3.3.3 The carriage of substances which have not been categorised, provisionally assessed or evaluated as referred to in 3.1.2.9 or of ballast water, tank washings or other mixtures containing such residues shall be prohibited along with any consequential discharge of such substances into the sea.

3.3.3.4 The discharge into the sea of residues of noxious liquid substances is to be made below the waterline through the underwater discharge outlet not exceeding the maximum rate for which the underwater discharge outlet is designed.

3.3.3.5 Equipment and arrangement of piping for the transfer and the discharge of noxious liquid substance residues shall comply with requirements of *Rules for the classification of ships, Part 8 - Piping* and *Part 27 - Chemical tankers*.

3.3.3.6 Discharge of residues of Category X

Subject to the provision of 3.3.3.1, 3.3.3.2 and 3.3.3.3, the following provisions shall apply:

- .1 A tank from which a substance in Category X has been unloaded, shall be pre-washed before the ship leaves the port of unloading. The resulting residues shall be discharged to a reception facility until the concentration of the substance in the effluent to such facility, as indicated by analyses of samples of the effluent taken by the surveyor, is at or below 0.1% by weight. When the required concentration level has been achieved, remaining tank washings shall continue to be discharged to the reception facility until the tank is empty. Appropriate entries of these operations shall be made in the Cargo Record Book and endorsed by the surveyor appointed by the Party to the Convention.
- .2 Any water subsequently introduced into the tank may be discharged into the sea in accordance with the discharge standards in MARPOL 73/78, Annex II, Reg.13.2.

- .3 Where the Government of the receiving party is satisfied that it is impracticable to measure the concentration of the substance in the effluent without causing undue delay to the ship, that Party may accept an alternative procedure as being equivalent to obtain the required concentration in 3.3.3.6.1 provided that:

- .1 the tank is pre-washed in accordance with a procedure approved by the *Register* in compliance with 3.3.2; and
- .2 appropriate entries shall be made in the Cargo Record Book and endorsed by the surveyor referred to in 3.3.3.6.1.

3.3.3.7 Discharge of residues of Category Y and Z

Subject to the provision of 3.3.3.1, 3.3.3.2 and

3.3.3.3, the following provisions shall apply:

- .1 With respect to the residue discharge procedures for substances in Category Y or Z the discharge standards in MARPOL 73/78, Annex II, Reg.13.2 shall apply.
- .2 If the unloading of a substance of Category Y or Z is not carried out in accordance with the Manual, a pre-wash shall be carried out before the ship leaves the port of unloading, unless alternative measures are taken to the satisfaction of the surveyor referred to in 3.3.3.6.1 to remove the cargo residues from the ship to quantities specified in MARPOL 73/78, Annex II. The resulting tank washings of the pre-wash shall be discharged to a reception facility.
- .3 For High-Viscosity or Solidifying Substances in Category Y the following shall apply:
 - .1 a pre-wash procedure as specified in 3.3.2 shall be applied;
 - .2 the residue/water mixture generated during the pre-wash shall be discharged to a reception facility until the tank is empty; and
 - .3 any water subsequently introduced into the tank may be discharged into the sea in accordance with the discharge standards in MARPOL 73/78, Annex II, Reg.13.2.
- .4 For substances assigned to category Y that are persistent floaters with a viscosity equal to or greater than 50 mPa·s at 20°C and/or with a melting point equal to or greater than 0°C, as identified by 16.2.7 in column 'o' of chapter 17 of the IBC Code, the following shall apply in the areas defined in paragraph 9 of MARPOL Annex II, Regulation 13:
 - .1 a prewash procedure as specified in 3.3.2.10 shall be applied;
 - .2 the residue/water mixture generated during the prewash shall be discharged to a reception facility at the port of unloading until the tank is empty; and
 - .3 any water subsequently introduced into the tank may be discharged into

the sea in accordance with the discharge standards in MARPOL 73/78, Annex II, Regulation 13.2.

3.3.3.8 Operational requirements for ballasting and de-ballasting:

- .1 After unloading, and, if required, after a pre-wash, a cargo tank may be ballasted. Procedures for the discharge of such ballast are set out in MARPOL 73/78, Annex II, Reg.13.2.
- .2 Ballast introduced into a cargo tank which has been washed to such an extent that the ballast contains less than 1 ppm of the substance previously carried, may be discharged into the sea without regard to the discharge rate, ship's speed and discharge outlet location, provided that the ship is not less than 12 miles from the nearest land and in water that is not less than 25 metres deep. The required degree of cleanliness has been achieved when a pre-wash as specified in 3.3.2 has been carried out and the tank has been subsequently washed with a complete cycle of the cleaning machine for ships built before 1 July 1994 or with a water quantity not less than that calculated with $k=1.0$.
- .3 The discharge into the sea of clean or segregated ballast shall not be subject to the requirements of MARPOL 73/78, Annex II.

3.3.4 Cargo systems

3.3.4.1 Cargo system shall comply with the requirements of the *Rules for the classification of ships, Part 8 - Piping* and *Part 27 - Chemical tankers*.

3.3.4.2 Every ship constructed before 1st July 1986 shall be provided with a pumping and piping arrangement to ensure that each tank certified for the carriage of substances in Category X or Y does not retain a quantity of residue in excess of 300 litres in the tank and its associated piping and that each tank certified for the carriage of substances in Category Z does not retain a quantity of residue in excess of 900 litres in the tank and its associated piping.

A performance test shall be carried out in accordance with 3.3.4.6.

3.3.4.3 Every ship constructed on or after 1st July 1986 but before 1st January 2007 shall be provided with a pumping and piping arrangement to ensure that each tank certified for the carriage of substances in Category X or Y does not retain a quantity of residue in excess of 100 litres in the tank and its associated piping and that each tank certified for the carriage of substances in Category Z does not retain a quantity of residue in excess of 300 litres in the tank and its associated piping. A performance test shall be carried out in accordance with 3.3.4.6.

3.3.4.4 Every ship constructed on or after 1st January 2007 shall be provided with a pumping and piping arrangement to ensure that each tank certified for the carriage of substances in Category X, Y or Z does not retain a quantity of

residue in excess of 75 litres in the tank and its associated piping. A performance test shall be carried out in accordance with 3.3.4.6.

3.3.4.5 For a ship other than a chemical tanker constructed before 1st January 2007 which cannot meet the requirements for the pumping and piping arrangements for substances in Category Z referred to in 3.3.4.2 and 3.3.4.3 no quantity requirement shall apply. Compliance is deemed to be reached if the tank is emptied to the most practicable extent.

3.3.4.6 Assessment of residue quantities in cargo tanks, pumps and associated piping:

- 1 The procedure for testing the efficiency of cargo pumping systems by assessment of residue quantities in cargo tanks, pumps and associated piping is to be in accordance with MARPOL 73/78, Annex II, Appendix 5, item 3.
- 2 The cargo pumping systems should be designed to meet the required maximum amount of residue per tank and associated piping as specified in 3.3.4.2, 3.3.4.3 and 3.3.4.4.
- 3 Cargo pumping systems shall be tested with water to prove their performance. Such water tests shall, by measurement, show that the system meets the requirements of 3.3.4.2, 3.3.4.3 and 3.3.4.4. In respect of 3.3.4.2 and 3.3.4.3 a tolerance of 50 litres per tank is acceptable. The quantity measured is termed the *stripping quantity*. The stripping quantity of each tank shall be recorded in the ship's Manual. Pumping performance test shall be approved by the *Register*.
- 4 After having determined the stripping quantity of one tank, the *Register* may use the determined quantities for a similar tank, provided that the pumping system in that tank is similar and operating properly.

3.3.5 Cargo pump room

3.3.5.1 Cargo pump room shall comply with the requirements of the *Rules for the classification of ships, Part 27 - Chemical Tankers, Part 2 - Hull and Part 12 - Electrical installation*.

3.3.5.2 Control position of bilge piping system of cargo pump room shall be located outside the room.

3.3.5.3 Bilge piping system of cargo pump room shall provide for the possibility of transferring bilge effluent into a slop tank or cargo tanks.

3.3.6 Underwater discharge outlet location

3.3.6.1 Ships certified to carry substances of category X, Y or Z shall have an underwater discharge outlets.

3.3.6.2 For ships constructed before 1st January 2007 and certified to carry substances of category Z an underwater discharge outlet is not mandatory.

3.3.6.3 The underwater discharge outlet (or outlets) shall be located within the cargo area in the vicinity of the turn of the bilge and shall be so arranged as to avoid the re-intake of residue/water mixtures by the ship's seawater intakes.

3.3.6.4 If dual outlets are provided to achieve a higher permissible discharge rate, these should be located on opposite sides of the ship.

3.3.7 Underwater discharge outlet size

3.3.7.1 The underwater discharge outlet arrangement shall be such that the residue/water mixture discharged into the sea will not pass through the ship's boundary layer. To this end, when the discharge is made normal to the ship's shell plating, the minimum diameter of the discharge outlet is governed by the following equation:

$$D = \frac{Q_D}{5L} \quad [\text{m}] \quad (3.3.7.1)$$

where:

- D – minimum diameter of the discharge outlet, [m];
- L – distance from the forward perpendicular to the discharge outlet, [m];
- Q_D – maximum rate selected at which the ship may discharge a residue/water mixture through the outlet, [m³/h].

3.3.7.2 When the discharge is directed at an angle to the ship's shell plating, the relationship (3.3.7.1) shall be modified by substituting for Q_D the component of Q_D which is normal to the ship's shell plating.

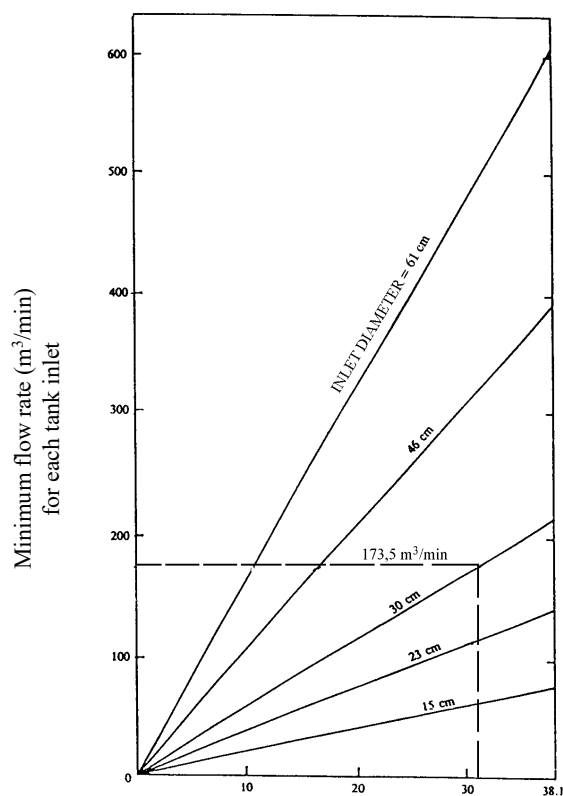

Figure 3.3.1.5
Inlet jet penetration depth [m]

3.4 SHIPBOARD MARINE POLLUTION EMERGENCY PLAN FOR NOXIOUS LIQUID SUBSTANCES

3.4.1 Every ship of 150 tons gross tonnage and above certified to carry noxious liquid substances in bulk shall carry on board a *Shipboard marine pollution emergency plan for noxious liquid substances* approved by the Register.

3.4.2 Plan shall be in accordance with Guidelines* developed by the Organisation and written in a working language of the master and officers. Plan shall consist at least of:

- .1 the procedure to be followed by the master or other persons having charge of the ship to report a noxious liquid substances pollution incident, as required in article 8 and Protocol I of the Convention MARPOL 73/78, based on the Guidelines developed by the Organisation**.
- .2 the list of authorities or persons to be contacted in the event of a noxious liquid substance pollution incident.
- .3 a detailed description of the action to be taken immediately by persons on board to reduce or control the discharge of noxious liquid substances following the incident.
- .4 the procedures and point of contact on the ship for co-ordinating shipboard action with national and local authorities in combating the pollution.

3.4.3 In the case of ships to which regulation 37 of Annex I of the Convention MARPOL 73/78 also apply, such a plan may be combined with the *Shipboard oil pollution emergency plan*. In this case, the title of a plan shall be *Shipboard marine pollution emergency plan*.

* Refer to *Guidelines for the development of shipboard marine pollution emergency plans for oil and/or noxious liquid substances*, according to IMO Res. MEPC.85(44) as amended by IMO Res. MEPC.137(53).

** Refer to *General principles for ship reporting systems and ship reporting requirements, including Guidelines for reporting incidents involving dangerous goods, harmful substances and /or marine pollutants*, according to resolution A.851(20), as amended by IMO Res. MEPC.138(53).

4 PREVENTION OF POLLUTION BY HARMFUL SUBSTANCES CARRIED BY SEA IN PACKAGED FORM

4.1 This Section applies on all ships carrying harmful substances in packaged form. Annex III of MARPOL 73/78 entered into force on 1 July 1992.

Detailed requirements on carriage of harmful substances in packaged form are contained in IMO Res. MEPC.193(61).

4.2 **Harmful substances** – for the purpose of this Section, are those substances which are identified as marine pollutants in the IMDG Code.

4.3 **Packaged form** – for the purpose of this Section, is defined as the form of containment specified for harmful substances in the IMDG Code.

4.4 Carriage of harmful substances is prohibited, except in accordance with the provisions of this Section.

4.5 The requirements of this Section do not apply to ship's store and equipment.

4.6 Packages shall be adequate to minimise the hazard to the marine environment, having regard to their specific contents.

4.7 Packages containing a harmful substance shall be durably marked or labelled to indicate that the substance is a harmful substance in accordance with the relevant provisions of the IMDG Code.

The method of affixing marks or labels on packages containing a harmful substance shall be in accordance with the relevant provisions of the IMDG Code.

Transport information relating to the carriage of harmful substances shall be in accordance with the relevant provisions of the IMDG Code.

4.8 Harmful substances shall be properly stowed and secured so as to minimize the hazards to the marine environment without impairing the safety of the ship and persons on board.

A ship shall carry a detailed stowage plan setting forth the harmful substances on board and the location thereof.

4.9 Certain harmful substances may need to be prohibited for carriage or be limited as to the quantity which may be carried aboard a ship. In limiting the quantity, due consideration shall be given to size, construction and equipment of the ship, as well as the packaging and the nature of the substances.

4.10 Jettisoning of harmful substances carried in packaged form shall be prohibited, except where necessary for the purpose of securing the safety of the ship or saving life at sea.

Subject to the provisions of the Convention, appropriate measures based on the physical, chemical and biological properties of harmful substances shall be taken to regulate the washing of leakages overboard.

5 PREVENTION OF POLLUTION BY SEWAGE

5.1 GENERAL

5.1.1 Application

5.1.1.1 Annex IV of MARPOL 73/78 entered into force on 27th September 2003.

5.1.1.2 This Section of present *Rules* apply to the arrangement and equipment of ships intended for prevention of pollution by sewage.

5.1.1.3 The provisions of this Section shall apply to following ships engaged on international voyages:

- .1 new ships of 400 tons gross tonnage and above;
- .2 new ships of less than 400 tons gross tonnage which are certified to carry more than 15 persons;
- .3 existing ships of 400 gross tonnage and above, five years after the date of entry into force of Annex IV of MARPOL 73/78.
- .4 existing ships of less than 400 gross tonnage which are certified to carry more than 15 persons, five years after the date of entry into force of Annex IV of MARPOL 73/78.

5.1.1.4 The provisions of this Section shall also apply to ships engaged on voyages within area of navigation 5 to 8, in dependence of size and type of ship which is in each particular case subject to consideration and decision by the Administration.

5.1.1.5 The provisions of 5.2.1.2 apply to new passenger ships on or after 1st June 2019 and to existing passenger ships on or after 1st June 2021.

5.1.1.6 Guidelines on effluent standards and performance test for sewage treatment plants in Res. MEPC.227(64) shall be applied on or after 1st January 2016.

The requirements of these guidelines will apply to sewage treatment plants installed onboard ships the keels of which are laid or which are at a similar stage of construction on or after 1st January 2016. For other ships, the requirements of these guidelines will apply to installations with a contractual delivery date to the ship on or after 1st January 2016, or in the absence of a contractual delivery date, the actual delivery of the equipment to the ship on or after 1st January 2016.

5.1.2 Definitions

The explanation of terms and expressions, used in all Sections, is specified in Section 1 - General.

The following terms and expression are applied in the present Section:

5.1.2.1 New ship – means a ship:

- .1 for which the building contract is placed, or in the absence of a building contract, the

keel of which is laid, or which is at a similar stage of construction, on or after the date of entry into force Annex IV of MARPOL 73/78; or

- .2 the delivery of which is three years of more after the date of entry into force Annex IV of MARPOL 73/78.

5.1.2.2 Existing ship – means a ship which is not a new ship.

5.1.2.3 Sewage (black water) – means:

- .1 drainage and other wastes from any form of toilets, urinals, and WC scuppers;
- .2 drainage from medical premises (dispensary, sick bay, etc.) via wash basins, wash tubs and scuppers located in such premises;
- .3 drainage from spaces containing living animals; or
- .4 other waste waters when mixed with the drainage defined above.

5.1.2.4 Sewage (grey water) – from domestic and accommodation spaces:

- .1 waste waters from basins, shavers, wash tubs and scuppers except waters as specified in 5.1.2.3.
- .2 waste waters from laundries.
- .3 waste waters from food washings, galley's equipment and provision's rooms (stores).

5.1.2.5 Holding tank – means a tank used for the collection and storage of sewage.

5.1.2.6 Sewage treatment plant – is a plant intended to comminute and disinfect the sewage with:

- .1 a biologically detachment of organic substances
- .2 a disinfection and a sterilisation
- .3 a separation of solid substances and their comminute or removal.

5.1.2.7 Number of persons – crew, passengers and special personnel shall be in accordance with the number of places intended for their accommodation in board.

5.1.2.8 Faecal coliform bacteria – are bacteria number of which is usually taken for the presence of faecal substances and the micro-organism which might be hazardous to human health.

5.1.2.9 Biochemical oxygen demand – BOD is a quantity or oxygen needed in the biochemical oxidation process of the organic substances in the sewage during 5-day testing.

5.1.2.10 Discharged solid substances – mean weight of the discharged solid substances found in testing 40 samples of the sewage.

5.1.2.11 Aerobic process – a biochemical oxidative process for breaking down the sewage by naturally occurring bacteria, which strips oxygen from the water, producing more water, carbon dioxide and new bacteria.

5.1.2.12 Sewage gasses – toxic and flammable gasses, which may occur in sewage system. If insufficient oxygen is present, alternative bacteria become dominant and the process becomes anaerobic with the production of gasses, including

hydrogen sulphide (H₂S), methane (CH₄), ammonia (NH₃), etc. The gasses have highly toxic and flammable properties, in particular hydrogen sulphide is toxic to humans in concentrations as low as 10 parts per million and its flammable vapours are heavier than air so that potentially lethal pockets of gas may accumulate in enclosed spaces.

5.1.2.13 Anaerobic conditions – conditions in sewage system leading to the production of toxic and flammable sewage gasses.

5.1.2.14 Special area – sea areas determined in MARPOL 73/78, Annex IV, Regulation 5bis.

5.1.2.15 Passenger – every person other than the master and the crew members or other persons employed or engaged in any capacity onboard a ship on the business of that ship, and children under one year of age.

5.1.2.16 Passenger ship – a ship which carries more than twelve passengers.

5.1.2.17 New passenger ship – a passenger ship for which the building contract is placed, or in the absence of a building contract, the keel of which is laid, or which is in a similar stage of construction, on or after 1st June 2019, or the delivery of which is on or after 1st June 2021.

5.1.2.18 Existing passenger ship – a passenger ship which is not a new passenger ship.

5.1.2.19 Unmanned non-self-propelled (UNSP) barge – means a barge that:

- .1 is not propelled by mechanical means;
- .2 has neither persons nor living animals on board;
- .3 is not used for holding sewage during transport; and
- .4 has no arrangements that could produce sewage as defined in item 5.1.2.3 and 5.1.2.4 of this Section.

5.1.3 Scope of supervision

5.1.3.1 Intentionally blank.

5.1.3.2 Supervision during manufacture shall cover:

- .1 sewage treatment plant including belonging pipeline, pumps and electrical equipment, dosimeters and monitoring and control devices;
- .2 holding tanks and the associated equipment.

5.1.3.3 The supervision of monitoring on board shall cover:

- .1 sewage treatment plant;
- .2 comminution and disinfection plant;
- .3 holding tanks;
- .4 pumps and sewage piping.

5.1.3.4 Before the manufacture is commenced, the following documentation shall be submitted to the *Register* for approval:

- .1 technical description and the principle of the plant operation, operating and maintenance manual;

- .2 general plan with cross sections of the sewage treatment plant, holding tank drawing;
- .3 monitoring and control scheme;
- .4 electrical schemes;
- .5 testing program.

5.2 ARRANGEMENT AND EQUIPMENT FOR TREATMENT AND DISCHARGE OF SEWAGE

5.2.1 General requirements

5.2.1.1 Ships specified in 5.1.1 shall be fitted with any one of this kind of equipment:

- .1 a type approved sewage treatment plant including a holding tank, which shall meet operational requirements based on standards and the test methods developed by the Organisation (IMO Res. MEPC.159(55));
- .2 approved system to comminute and disinfect the sewage (black water), including a holding tank, for the later discharge at sea at a distance more than 3 Nm from the nearest land.
- .3 a holding tanks for the later discharge of sewage into the reception facilities or other ship's facilities, or the discharge at sea at a distance more than 12 Nm from the nearest land at a moderate rate approved by *Register* when the ship is en route and proceeding at not less than 4 knots, the capacity of such tank shall be to the satisfaction of the *Register* for the retention of all sewage having regard to the operation of the ship, the number or persons on board and other relevant factors.

5.2.1.2 Every passenger ship while in a special area shall be equipped with one of the following sewage systems:

- .1 a type approved sewage treatment plant, which shall meet operational requirements taking into account the standards and test methods developed by the Organisation (IMO Res. MEPC.227(64) and IMO Res. MEPC.284(70));
- .2 a holding tank of the construction and capacity to the satisfaction of the Register for the retention of all sewage for the later discharge into the reception facilities, with regard to the operation of the ship, number of persons onboard and other relevant factors. The holding tank shall have means to indicate visually the amount of its contents.

5.2.1.3 Category A and B ships constructed on or after 1st January 2017 and all passenger ships constructed on or after 1st January 2017 are allowed to discharge sewage within polar waters when the ship has in operation a sewage treatment plant approved in accordance with 5.2.1.1.1 or 5.2.1.2.1, and as far as practicable from the nearest land, any ice-shelf, fast ice or areas of ice concentration exceeding 1/10.

5.2.1.4 Category A and B ships that operate in areas of ice concentrations exceeding 1/10 for extended periods of time, may only discharge sewage using a sewage treatment plant approved in accordance with 5.2.1.1.1 or 5.2.1.2.1.

5.2.1.5 Sewage effluent system shall be such as to avoid the uncontrolled discharge into the sea.

5.2.1.6 Piping, electrical equipment and automation shall comply with the requirements of the *Rules for the classification of ships, Part 7 - Machinery, Part 8 - Piping, Part 12 - Electrical Equipment, Part 13 - Automation*.

On ships with area of navigation 6-8, of less than 400 tons gross tonnage, plastic pipes in sanitary water system outside machinery space, need not be type approved according to IMO Res. A. 753 (18), if plastic pipes comply with the requirements of recognised standards and their range of application includes black and grey water piping.

5.2.1.7 Sewage pipeline shall be of the adequate dimensions as to avoid its clogging or revert circulation of sewage. Pipeline shall be protected from freezing.

5.2.1.8 Sewage pipeline shall not pass through spaces where food is stored, prepared or served, or through pantries. Where these requirement cannot be complied with, due to structural reasons, provisions shall be made for alternatives, in which the part of pipeline passing through the mentioned spaces has no removing connection or such connections are minimised and so protected as to prevent leakage of sewage into such space.

Drain openings shall not be fitted on the pipeline section passing through above mentioned spaces.

Sewage pipeline shall not pass through medical spaces.

5.2.1.9 Pipelines shall be tested for tightness in compliance with 5.2.3.7.

5.2.1.10 Adequate air vents shall be fitted to the piping network, paying special attention to the extremities of the system. These should ensure an adequate supply of air and obviate any tendency for plugs of water to form within the system, tending to syphon or create vacuums thus removing water seals, when moving through the pipes especially under the action of violent rolling or pitching.

The arrangement of the venting pipes shall be in accordance with 5.2.2.7.

5.2.1.11 In general, the sewage system shall be of a design, which will avoid potential risk of hazardous gasses within the system. The primary safety features should be incorporated in the design and operation of a sewage system and the barriers between the sewage gasses such as water traps of the toilet bowls, ventilation of the pipework and tanks should only be considered as secondary means of protection. The primary objective shall be the prevention of the production and accumulation of the toxic and flammable sewage gasses within the system.

5.2.1.12 It is recommended that toilet bowls be often fitted with a vacuum breaking arrangements at the back of the water trap such as individual air pipes or patented backflow prevention valves.

5.2.1.13 When the sewage is mixed with wastes or waste water covered by other Sections of present Rules, the

requirements of those Sections shall be complied with in addition to the requirements of this Section.

Drain lines from the hospital area shall be, as far as practicable, separated from other discharges and fitted to the holding tank at the lowest level.

5.2.1.14 Drain lines from refrigerating rooms for provisions shall be led to holding tank separately from other waste water drains.

Scuppers, if fitted inside refrigerating rooms for provisions, shall be of execution suitable for cold storage temperatures. Guidance note: Suitable execution would be scupper which can be manually closed or fitted with seal plug.

Condensation water from refrigerating rooms for provisions may be discharged into the bilge by means of a separate drain line.

5.2.1.15 Temporary storage of treated sewage/grey water in ballast water tanks may be used as an option in specific ports and areas which restrict the discharge of treated sewage/grey water and where the ship does not have dedicated tanks with adequate storage capacity for treated sewage/grey water. Guidance for the temporary storage of treated sewage and/or grey water in ballast water tanks is given in BWM.2/Circ.82.

5.2.2 Sewage holding tanks

5.2.2.1 Total capacity of all holding tanks may be determined by the formulae:

$$V = f \cdot n \cdot q \cdot t \quad [\text{lit}] \quad (5.2.2.1)$$

where:

- f – exploitation factor:
 - = 1,0 for ships of non-restricted and restricted area of navigation, if the voyage takes more than 8 hours;
 - = 0,3-0,5 for passenger ships, if the voyage takes 2 till 4 hours;
 - = 0,1 for passenger ships, if the voyage takes up to 2 hours;
- n – number of persons;
- q – quantity of effluent (sewage) in litres per person a day:
 - = 70 lit/person a day, if collecting black water sewage
 - = 180-230 lit/person a day, if collecting black water sewage and grey water sewage from the domestic and accommodation space (large quantities for passenger ships):
 - = 25 lit/person a day, if collecting black water sewage with vacuum system
 - = 135-185 lit/person a day, if collecting black water sewage with vacuum system and grey water sewage from the domestic and accommodation space (large quantities for passenger ships):
- t – time of the ship's stay in port and/or the area where the discharge is not permitted;

- = 1 day for passenger ships on one-day touristic excursions
- = 3-5 days for tankers in non-restricted area of navigation;
- = 3-10 days for cargo ships in non-restricted area of navigation;
- = 3 days for other ships;
- = 2 days for the ships provided with the sewage treatment plants.

5.2.2.2 Structural holding tanks shall comply with the requirements of the *Rules for the classification of ships, Part 2 - Hull*.

5.2.2.3 Holding tanks shall be made of steel or stainless steel. On ships whose hull is manufactured from aluminium alloys or plastic materials, collecting tanks may be manufactured from these materials. The internal surfaces shall be smooth (except those of structural tanks) and protected against reaction of the liquid being carried. The tank bottom shall be inclined towards suction pipe. Tanks shall be provided with the washing machine using water or steam and the openings for inspection and cleaning. Mixture device for mixing sewage is recommended to be installed.

Washing machine for holding tanks need not to be installed on ships with area of navigation 5-8.

5.2.2.4 Holding tanks shall be segregate (dry spaces or cofferdams) from drinking water and boiler water tanks, fresh water tanks, vegetable oil tanks as well as from accommodation and cargo spaces. Holding tanks may be without cofferdams in machinery and cargo spaces provided that such spaces are not intended for the carriage of eatables and products.

5.2.2.5 Prior to protection coating, holding tanks shall be tested by test pressure 1.5 times above the water column pressure measured from bottom to the lowest sanitary equipment which has no possibility of closing the discharge outlet, but not less than 2.5 m of the water column.

5.2.2.6 Holding tanks shall be provided with audible and visual alarms to warn that the level in tank exceeds 80% of the tank depth.

5.2.2.7 Ventilation pipes to collection, storage and treatment tanks shall be of adequate size to minimise pressure drop and to ensure satisfactory clearance of sewage gasses. The size of the vent pipes should also be sufficient to vent any air from blowers or from vacuum collection system discharges if installed.

Air pipes from the black and grey water systems are to be independent of all other air pipes and are to be led to the outside of the ship, away from any air intake. Air pipe openings shall be protected with a non-corrosive mesh.

Such pipes shall not terminate in areas to which personnel have frequent access and shall be clear of any sources of ignition. If this is not practical, air pipes shall be fitted with suitable arrangements for eliminating bad odours and hazardous gases produced by the black and grey water systems.

Ventilation pipes shall be self-drained at all angles of heel and trim and so arranged to avoid giving of smell into accommodation, public, working and medical spaces.

5.2.2.8 The design of the tank may include features to maintain an adequate oxygen level in the liquid, thereby

eliminating anaerobic conditions. This may be achieved by direct air injection, or by air entrainment into the liquid whilst pumping through an ejector nozzle, etc.

5.2.2.9 Where holding tank is situated in the double-bottom space, structural measures shall be taken to prevent penetration of water into particular watertight space through the open ends of the drain pipes in the event of damage to the shell plating.

5.2.3 Sewage treatment plants

5.2.3.1 The capacity of sewage treatment plant shall be determined by the formulae:

$$Q = n \cdot q \text{ [lit/day]} \quad (5.2.3.1)$$

where n and q are the same as in 5.2.2.1.

5.2.3.2 Sewage treatment plants, associated pumps, piping and their outfitting which come in contact with sewage effluent shall be of the material resistant to its hazardous reaction or shall be specially protected.

5.2.3.3 If chlorine is used for the disinfection of sewage effluent, the chlorine content in the water discharged into sea shall not exceed 0,5 mg/lit.

5.2.3.4 The sewage treatment plant shall ensure the following effluent standard:

- .1 biochemical oxygen demand (BOD₅):
25 mg/lit
- .2 chemical oxygen demand (COD):
125 mg/lit
- .3 total suspended solids:
 - .1 when the plant is tested in land:
35 mg/lit
 - .2 when the plant is tested on board:
 $x + 35$ mg/lit

x - the content of suspended solids in water for flushing of the sewage treatment plant [mg/lit]
- .4 faecal coliform bacteria: 100/100 ml
- .5 pH value: 6-8,5

5.2.3.5 The sewage treatment plant installed on a passenger ship intending to discharge sewage effluent in special areas shall additionally meet the following effluent standards for the geometric mean of the total nitrogen and phosphorus content of the samples of effluent taken during the test period:

- .1 total nitrogen: 20 mg/lit or at least 70% reduction in relation to influent load
- .2 total phosphorus: 1,0 mg/lit or at least 80% reduction in relation to influent load.

5.2.3.6 The treatment plant shall be tested for tightness in accordance with 5.2.2.5.

5.2.3.7 Pipelines shall be tested with test pressure:

$$p_{ts} = 1,5 \cdot p \quad [\text{MPa}] \quad (5.2.3.6)$$

where:

p – working pressure.

5.2.3.8 Functional testing of the plant shall be carried out in the factory or on board in compliance with the program approved by *the Register*.

5.2.3.9 The plants may be located in the machinery space or in the gastight spaces with forced ventilation.

5.2.3.10 The efficient system of washing and disinfection of the plant shall be provided as well as the control system and pipeline (opening for inspection and repair shall be also provided).

5.2.3.11 Provisions shall be made for the automatic operation of the plant and for audible and visual alarm in case of overflow or in case of malfunction of the plant.

5.2.3.12 The plant shall be provided with the vent pipe arranged in accordance with 5.2.2.7.

5.2.3.13 Prior to and after the treatment, provisions shall be made for taking the samples of effluent.

5.2.3.14 The ship shall have onboard operating and maintenance manual for the sewage treatment plant.

The type and model of the sewage treatment plant and the name of the manufacturer, date of manufacture and any operational or installation limits shall be noted on a durable label firmly affixed on the plant.

5.2.4 Sewage system to comminute and disinfect

5.2.4.1 Sewage system to comminute and disinfect shall comply with the requirements 5.2.3.1 to 5.2.3.3 and 5.2.3.8 to 5.2.3.13.

5.2.4.2 Holding tanks in relation with the system shall comply with the requirements of 5.2.2.

5.2.4.3 The system shall comminute solid substances in sewage to the particles not exceeding 25 mm.

5.2.5 Discharge of sewage

5.2.5.1 Two pumps shall be provided for the discharge of sewage effluent. One ejector may be provided instead of a pump. Exceptionally, the *Register* may permit the fitting of one pump only.

5.2.5.2 Every ship shall be provided with a pipeline for the discharge of sewage into reception facilities. The pipeline on either side of the ship shall be provided with the international discharge connection according to Fig.5.2.5.2. For smaller ships The *Register* may permit only one discharge connection. Discharge outlets shall be provided with blank flanges.

A position on the deck where the effluent discharge may be visually observed shall be provided with means for stopping the discharge pumps or with a positive communication system with a discharge control position. The ships of less than 30 m in length, subject to the agreement with the *Register*, need not be provided with the remote control or a communication system.

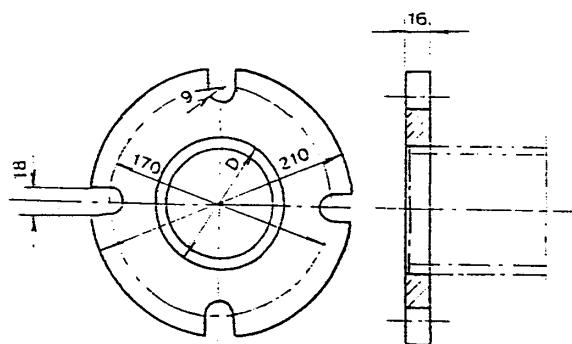

Figure 5.2.5.2
Standard flange of discharge connection

The flange is designed to accept pipes up to a maximum internal diameter of 100 mm and shall be of steel or other equivalent material having a flat face. This flange, together with a suitable gasket, shall be suitable for a service pressure of 0.6 MPa. Fastening bolts to be M 16.

For ships having a moulded depth of 5 metres and less, the inner diameter of the discharge connection may be 38 millimetres.

5.2.5.3 For ships in dedicated trades, i.e. passenger ferries, alternatively the ship's discharge pipeline may be fitted with a discharge connection which can be accepted by the *Register*, such as quick connection couplings.

5.2.6 Unmanned non-self-propelled barges

5.2.6.1 The Administration may exempt an unmanned non-self-propelled (UNSP) barge from the certain survey and certification requirements of Annex IV by means of an International Sewage Pollution Prevention Exemption Certificate for Unmanned Non-self-propelled (UNSP) Barges, for a period not exceeding five years provided that the barge has undergone a survey to confirm that conditions referred to in 5.1.2.19 of this Section are met.

Guidelines for the exemption of unmanned non-self-propelled barges from certain survey and certification requirements under the MARPOL Convention are given in MEPC.1/Circ.892. In addition to requirements stated in MEPC.1/Circ.892, specific requirements of the Administration should also be followed, if any.

5.2.6.2 In accordance with 5.2.6.1, the International Sewage Pollution Prevention Exemption Certificate for Unmanned Non-self-propelled Barges shall be drawn up in the form corresponding to the model given in appendix II of Annex IV of IMO Res. MEPC.330(76) and shall be at least in English, French or Spanish. If an official language of the issuing country is also used, this shall prevail in the event of a dispute or discrepancy.

6 PREVENTION OF POLLUTION BY GARBAGE

6.1 GENERAL

6.1.1 Application

6.1.1.1 Annex V, MARPOL 73/78 entered into force on 31st December 1988.

6.1.1.2 This Section of present Rules apply to the arrangement and equipment of ships intended for prevention of pollution by garbage.

6.1.1.3 The requirements of this Section of present Rules apply to all ships.

6.1.2 Definitions

The explanation of terms and expressions, used in all Sections, is specified in Section 1 - General. The following terms and expressions are applied in the present Section:

6.1.2.1 Wastes – means useless, unneeded or superfluous matter which is to be discharged.

6.1.2.2 Garbage – means all kinds of food wastes, domestic and operational wastes, all plastics, cargo residues, cooking oil, fishing gear and animal carcasses (excluding fresh fish and parts thereof), generated during the normal operation of the ship and liable to be disposed of continuously or periodically except those substances which are defined or listed in other Sections to the present Rules (for example oils, chemicals, etc).

6.1.2.3 Incinerator – means shipboard facilities for incinerating solid wastes approximating in composition to household waste and liquid wastes arising from the operation of the ship, e.g., domestic waste, cargo residues, cargo-associated waste, maintenance waste, operational waste and fishing gear, etc. These facilities may be designed to use or not to use the heat energy produced.

6.1.2.4 Equipment for processing garbage – (comminuter, grinder, compactor) means the equipment for comminution of garbage or to reduce its volume.

6.1.2.5 Garbage collecting equipment – means containers and other equipment for collecting and storage of garbage.

6.1.2.6 Number of persons – means crew, passengers and special staff (personnel) in relation to number of places intended for their accommodation on board.

6.1.2.7 Special areas – for the purpose of Regulations in this Section, areas determined in MARPOL 73/78, Annex V, Regulation 1(14).

6.1.3 Scope of supervision

6.1.3.1 Intentionally blank.

6.1.3.2 The *Register* shall carry out supervision during manufacture over:

- .1 incinerators;
- .2 equipment for processing garbage;
- .3 monitoring and control device.

6.1.3.3 The *Register* shall carry out supervision during mounting on board ship over:

- .1 incinerator;
- .2 equipment for processing garbage;
- .3 garbage collection equipment.

6.1.3.4 Prior to the commencement of the manufacture, the documentation which shall be submitted to The *Register* for approval is the following:

- .1 Incinerator:
 - .1 technical description and work principle;
 - .2 general plan with cross sections (design, capacity, scantlings, materials and protection);
 - .3 firing (burning) device drawing;
 - .4 fill-up device drawing;
 - .5 fuel scheme;
 - .6 electrical scheme;
 - .7 monitoring and control scheme;
 - .8 testing program.
- .2 Equipment for processing garbage:

Documentation referred to in 6.1.3.4-.1 excluding items 3, 4 and 5.
- .3 Garbage collection equipment:
 - .1 drawing of the equipment and cross sections (design, capacity, scantlings, materials and protection)
 - .2 capacity calculation.

6.2 ARRANGEMENT AND EQUIPMENT FOR COLLECTION AND PROCESSING OF GARBAGE AND INCINERATION OF WASTES

6.2.1 General requirements

6.2.1.1 Every ship shall be provided with the one of the following equipment:

- .1 garbage collecting equipment; or
- .2 garbage processing equipment; or
- .3 garbage incinerator.

6.2.1.2 Garbage processing equipment's and wastes incinerators shall comply with the requirements of the *Rules for the classification of ships, Part 8 - Piping, Part 12 - Electrical equipment and Part 13 - Automation.*

6.2.2 Garbage collection equipment

6.2.2.1 The equipment may be portable or incorporated into hull structure but not into double bottom structure.

6.2.2.2 The capacity of the garbage collection equipment is recommended to be determined by the formulae:

$$V = n \cdot q \cdot t \cdot 10^{-3} \text{ [m}^3\text{]} \quad (6.2.2.2)$$

where:

- n – number of persons;
- q – 5 dm³ per person (daily rate of garbage per person);
- t – time of the ship's stay in areas where garbage disposal is not permitted;
 - = 3 to 10 days for dry cargo carriers (ships) of non-restricted area of navigation;
 - = 3 to 6 days for tankers of non-restricted area of navigation;
 - = 3 days for other ships.

All ships operating in the Antarctic area shall have sufficient capacity of garbage collection equipment, for the retention of all garbage while in the area, in order to discharge it to reception facilities.

6.2.2.3 Garbage collection equipment incorporated into hull structure shall be of steel. Inside wall surface shall be smooth and the bottom inclined 30° towards the discharge outlet. The discharge outlets shall not be provided with collar on the lower part.

Covers of the discharge outlets shall be provided with the opening device enabling safe operation under all conditions of navigation.

6.2.2.4 Inside surfaces of the portable garbage collection equipment shall be smooth.

6.2.2.5 Portable equipment shall be attached securely on board (securing device).

6.2.2.6 Openings for garbage shall be provided with covers which can be securely closed.

6.2.3 Garbage processing equipment

6.2.3.1 Comminuters shall comminute garbage to the particles not exceeding 25 mm.

6.2.3.2 Compactors shall reduce the volume of garbage at least 12 times.

6.2.3.3 The equipment for the discharge of processing garbage into sea shall be located under the deck and shall be provided with watertight covers.

6.2.3.4 The equipment for the discharge of processing garbage provided with plates with instruction for their use.

6.2.4 Equipment for incineration of garbage (incinerators)

6.2.4.1 Incinerators, in addition to the possibility of direct charge with garbage, shall be provided with a storage receptable for garbage (waste).

Covers on the garbage storage receptable shall be provided with the stopping device which precludes simultaneous opening of two or several covers. If storage (charge) of some materials for incinerator is limited (e.g. waste oil, oil residue, etc.) such limitations shall be clearly indicated on the table fitted in the conspicuous place.

6.2.4.2 Provision shall be made for the control of combustion process directly or indirectly.

6.2.4.3 Burning units (burners) or other fuel supply devices shall be of the type approved by the *Register*.

6.2.4.4 Fuel supply line shall be provided with a device which enable the supply of fuel only:

- .1 when the burner is ready to operate;
- .2 when the combustion air is flowing into the combustion chamber.

6.2.4.5 Fuel supply line shall be provided with a device for automatic shut down of the fuel supply to the burner in intervals not exceeding 5 seconds, if:

- .1 combustion air supply to combustion chamber is cut off;
- .2 the flame is gone out;
- .3 failure of electrical supply;
- .4 fuel pressure drop is under the permissible working pressure.

6.2.4.6 In case that the fuel does not ignite within 5 seconds, the fuel supply shall be automatically shut down.

6.2.4.7 The burners shall be capable of being shut down from two positions, one of which shall be outside of the space where the incinerator is located.

6.2.4.8 Drip trays shall be fitted on places where fuel leakage might occur with the possibility of efficient discharge.

6.2.4.9 The ash and other combustion remains shall be stored in the portable receptacles with covers which can be securely attached on board (securing device).

6.2.4.10 The incinerator surfaces exposed to excessive heating shall be insulated in accordance with, the requirements of the *Rules for the classification of ships, Part 7 - Machinery installation*, 1.11.9.

6.2.4.11 The exhaust gas system shall be in accordance with the *Rules for the classification of ships, Part 8 - Piping*, Section 6.

6.2.4.12 Burner automatic ignition program shall be:

- combustion space to be ventilated at least 3 minutes prior to ignition;
- combustion space to be ventilated at least 3 minutes after the flame is gone.

In case that a separate blower for the extended operation is provided after the flame is gone, the latter requirement need not be fulfilled.

6.2.4.13 Incinerators with the automatic combustion process shall be provided with alarm for the cases referred to in the Table 6.2.4.13.

6.2.4.14 When charging the combustion chamber of incinerator which is not provided with the storage receptacle, the combustion chamber door shall be capable of being blocked in case that:

- .1 during combustion air supply for combustion chamber;
- .2 the temperature in combustion chamber exceeds the flash point of fuel evaporations being used on board.

6.2.4.15 Incinerator plants with capacities up to 4000 kW per unit shall be in compliance with MARPOL 73/78, Annex

V, Guidelines for the implementation of Annex V, i.e. IMO Res. MEPC.244(66), as amended by IMO Res. MEPC.368(79).

6.2.4.16 Requirements related to shipboard incineration related to the prevention of air pollution are stated in 7.3.5.

6.2.5 Arrangements and equipment location

6.2.5.1 Portable garbage collection equipment shall be located on the open deck or in the spaces separated from the accommodation and service spaces which can be with forced ventilation.

6.2.5.2 Comminuters and compactors shall be located in the spaces separated from accommodation and service spaces which can be with forced ventilation.

6.2.5.3 Incinerators may be located in the machinery spaces or in (special) separate spaces.

- .1 If located in the machinery space it shall be separated by screen and shall be in

accordance with the *Rules for the classification of ships, Part 7 - Machinery* 1.12 and 1.13.

- .2 If located in separate space, such a space shall be considered as service space and shall be in accordance with the *Rules for the classification of ships, Part 17 - Fire-fighting*, 1.5.8.1.

6.2.5.4 In case that incinerator is located in separate space, provision shall be made for:

- .1 Pressure-vacuum ventilation which provide sufficient quantity of air for the incinerator operation;
- .2 Automatic fire alarm in accordance with for the *Rules for the classification of ships, Part 17 - Fire-fighting*.
- .3 Fire-fighting system in accordance with the *Rules for the classification of ships, Part 17 - Fire-fighting*.

Table 6.2.4.13
Monitoring of incinerators

		Alarm	Fuel automatic shut-off	Remarks
1		2	3	4
High temperature of exhaust gases		-	+	
High temperature in combustion chamber		-	+	
Ventilator switch-off		-	+	If suction ventilator is not available, stand-by ventilator is put in operation
Suction ventilator switch-off		-	+	If fitted
Fuel temperature	high	+	-	
	low	+	-	High viscosity
Fuel pump low pressure		-	+	If fuel pump in necessary in normal work
Flame is gone or failure		-	+	Each burning valve shall have possibility of automatic shut-off of fuel supply
Fuel supply failure or combustion air low pressure		-	+	
Automatic shut-off fuel supply		+	-	

6.3 PLACARDS, GARBAGE MANAGEMENT PLANS, GARBAGE RECORD BOOK

6.3.1 Placards

6.3.1.1 Every ship of 12 m or more in length overall and fixed or floating platforms shall display at appropriate places placards with guidelines for disposal of garbage.

6.3.1.2 Placards shall be made of durable material, with dimensions of not less than 200 x 125 mm and displayed at visible place on navigating bridge, dining rooms and on open deck, and for passenger ships also at places inside the ship and on open deck where more passenger gather.

6.3.1.3 Ships engaged in international voyages

Ships shall have placards written in the working language of the crew and additionally in English, French or Spanish with text according to MARPOL 73/78, Annex V, Regulation 3, 4, 5 and 6, and section 5.2 of part II-A of the Polar Code.

6.3.1.4 Ships of restricted service 5 to 8

Since according to MARPOL 73/78, Annex V, Regulation 3, the disposal of garbage is prohibited in Adriatic sea area, except as provided otherwise in Regulation 6, the placard with clearly written warning about the prohibition of disposal of garbage into the sea is to be displayed.

On passenger ships the placard is to be displayed in accommodation spaces and on open decks, and on other ships at least in dining room.

6.3.2 Garbage management plan

6.3.2.1 Every ship of 100 GT and above and every ship certified to carry 15 persons or more and fixed or floating platforms shall carry a garbage management plan.

6.3.2.2 Garbage management plan shall provide written procedures for minimizing, collecting, storing, processing and disposing of garbage, including the use of the equipment onboard, and designate the person in charge of carrying out the plan.

Plan written in the working language of the crew is to be in accordance with IMO Res. MEPC.220(63).

6.3.3 Garbage record book

6.3.3.1 Every ship of 100 GT and above and every ship certified to carry 15 persons or more engaged in international voyages and every fixed or floating platform shall be provided with a garbage record book.

Ships of 100 GT and above, and less than 400 GT shall be provided with a Garbage record book not later than 1 May 2024.

The Garbage Record Book, whether as a part of the ship's official logbook, or as an electronic record book which shall be approved by the Administration taking into account the Guidelines in IMO Res. MEPC.312(74), or

otherwise, shall be in the form specified in appendix II to MARPOL 73/78, Annex V.

Garbage record book shall be provided on every ship of 100 GT and above and every ship certified to carry 15 persons or more, if the duration of the voyage is more than one hour, in the restricted service areas 5 to 8, if so requested by the Administration.

6.3.3.2 The entries in the garbage record book, according to form in appendix to the Annex V, MARPOL 73/78, shall be in an official language of the state whose flag the ship is entitled to fly and for ships engaged in international voyages also in English, French or Spanish.

7 PREVENTION OF AIR POLLUTION

7.1 GENERAL

7.1.1 Application

7.1.1.1 The Protocol of 1997, to amend the *International Convention for the Prevention of Pollution from Ships, 1973, as modified by the Protocol of 1978 relating thereto* (i.e. *MARPOL 73/78 Convention*) entered into force on 19 May 2005. This Protocol introduced the Annex VI to the Convention, entitling the regulations for the prevention of air pollution from ships.

IMO Res. MEPC.328(76) Amendments to the annex of the Protocol of 1997 to amend the *International Convention for the Prevention of Pollution from Ships, 1973, as modified by the Protocol of 1978 relating thereto* (i.e. Revised *MARPOL Annex VI*) was adopted on 17 June 2021 and enters into force on 1 November 2022.

IMO Res. MEPC.177(58) Amendments to the Technical Code on Control of Emission of Nitrogen Oxides from Marine Diesel Engines, i.e. *NOx Technical Code 2008* was also adopted on 10 October 2008 and enters into force on 1 July 2010.

7.1.1.2 The provisions of this Section shall apply to all ships (as defined in item 1.1.2.4), except where expressly provided otherwise in items 7.1.3, 7.2.1, 7.2.2, 7.3.2, 7.3.4, 7.3.5 and 7.3.6.

7.1.1.3 The provisions of Regulation (EU) 2024/573 on fluorinated greenhouse gases shall apply to EU flagged ships with regard to installation and use of refrigeration equipment, chillers and air conditioning equipment that contains fluorinated greenhouse gases.

7.1.2 Definitions

The explanations of terms and expressions that refer to the general terminology in the *Rules are given in the Rules for the classification of ships, Part 1 - General requirements, Chapter 1 - General information*. For the purpose of this Section of the Rules the following definitions apply.

7.1.2.1 Annex – means Annex VI to the *International Convention for the Prevention of Pollution from Ships 1973 (MARPOL)*, as modified by the Protocol of 1978 relating thereto, and as modified by the Protocol of 1997, as amended by the IMO, provided that such amendments are adopted and brought into force.

7.1.2.2 A similar stage of construction – means the stage at which:

- .1 construction identifiable with a specific ship begins; and
- .2 assembly of that ship has commenced comprising at least 50 tonnes or one per cent of the estimated mass of all structural material, whichever is less.

7.1.2.3 Anniversary date – means the day and the month of each year which will correspond to the date of expiry of the *International Air Pollution Prevention Certificate*.

7.1.2.4 Auxiliary control device – means a system, function, or control strategy installed on a marine diesel engine that is used to protect the engine and/or its ancillary equipment against operating conditions that could result in damage or failure, or that is used to facilitate the starting of the engine. An auxiliary control device may also be a strategy or measure that has been satisfactorily demonstrated not to be a defeat device.

7.1.2.5 Continuous feeding – is defined as the process whereby waste is fed into a combustion chamber without human assistance while the incinerator is in normal operating conditions with the combustion chamber operative temperature between 850°C and 1200°C.

7.1.2.6 Defeat device – means a device which measures, senses, or responds to operating variables (e.g., engine speed, temperature, intake pressure or any other parameter) for the purpose of activating, modulating, delaying or deactivating the operation of any component or the function of the emission control system such that the effectiveness of the emission control system is reduced under conditions encountered during normal operation, unless the use of such a device is substantially included in the applied emission certification test procedures.

7.1.2.7 Emission – means any release of substances, subject to control by this Section from ships into the atmosphere or sea.

7.1.2.8 Emission Control Area – means an area where the adoption of special mandatory measures for emissions from ships is required to prevent, reduce and control air pollution from NO_x or SO_x and particulate matter or all three types of emissions and their attendant adverse impacts on human health and the environment. Emission Control Areas shall include those listed in, or designated under, 7.3.2 and 7.3.3.

7.1.2.9 Fuel oil – means any fuel delivered to and intended for use on board a ship.

7.1.2.10 Gross tonnage – means the measure of the overall size of a ship determined in accordance with the *Rules for tonnage measurement of maritime objects* (see item 1.3.1 of these Rules).

7.1.2.11 Installations – in relation to 7.3.1 means the installation of systems, equipment including portable fire-extinguishing units, insulation, or other material on a ship, but excludes the repair or recharge of previously installed systems, equipment, insulation, or other material, or the recharge of portable fire-extinguishing units.

7.1.2.12 Installed – means a marine diesel engine that is fitted, or is intended to be fitted, on a ship, including a portable auxiliary marine diesel engine, only if its fuelling, cooling, or exhaust system is an integral part of the ship. A fuelling system is considered integral to the ship only if it is permanently affixed to the ship. This definition includes a marine diesel engine that is used to supplement or augment the installed power capacity of the ship and is intended to be an integral part of the ship.

7.1.2.13 Irrational emission control strategy – means any strategy or measure that, when the ship is operated under normal conditions of use, reduces the effectiveness of an emission control system to a level below that expected on the applicable emission test procedures.

7.1.2.14 Marine diesel engine – means any reciprocating internal combustion engine operating on liquid or dual fuel, to which 7.3.2 applies, including booster/compound systems if applied. In addition, a gas fuelled engine installed on a ship constructed on or after 1 March 2016 or a gas fuelled additional or non-identical replacement engine installed on or after that date is also considered as a marine diesel engine.

7.1.2.15 NOx Technical Code – means the *Technical code on control of emission of nitrogen oxides from marine Diesel engines* adopted by resolution 2 of the 1997 MARPOL Conference, as amended by the IMO.

7.1.2.16 Ozone-depleting substances – means controlled substances defined in paragraph (4) of article 1 of the *Montreal Protocol on Substances that Deplete the Ozone Layer*, 1987, listed in Annexes A, B, C or E to the said Protocol.

Ozone-depleting substances that may be found on board ship include, but are not limited to:

Halon 1211	Bromochlorodifluoromethane
Halon 1301	Bromotrifluoromethane
Halon 2402	1,2-Dibromo-1,1,2,2-tetrafluoroethane (also known as Halon 114B2)
CFC-11	Trichlorofluoromethane
CFC-12	Dichlorodifluoromethane
CFC-113	1,1,2-Trichloro-1,2,2-trifluoroethane
CFC-114	1,2-Dichloro-1,1,2,2-tetrafluoroethane
CFC-115	Chloropentafluoroethane

7.1.2.17 Shipboard incineration – means the incineration of wastes or other matter on board a ship, if such wastes or other matter were generated during the normal operation of that ship.

7.1.2.18 Shipboard incinerator – means a shipboard facility designed for the primary purpose of incineration.

7.1.2.19 Ships constructed – means ships the keels of which are laid or which are at a similar stage of construction.

7.1.2.20 Sludge oil – means sludge from the fuel or lubricating oil separators, waste lubricating oil from main or auxiliary machinery, or waste oil from bilge water separators, oil filtering equipment or drip trays.

7.1.2.21 Tanker – means an oil tanker as defined in item 2.1.2.5, or a chemical tanker as defined in item 3.1.2.1.

7.1.2.22 Low-flashpoint fuel - means gaseous or liquid fuel oil having a flashpoint lower than 60°C.

7.1.2.23 MARPOL delivered sample - means the sample of fuel oil delivered in accordance with 7.3.6.5.

7.1.2.24 In-use sample - means a sample of fuel oil in use on a ship.

7.1.2.25 On board sample - means a sample of fuel oil intended to be used or carried for use on board a ship.

7.1.2.26 Unmanned non-self-propelled (UNSP) barge – means a barge that:

- .1 is not propelled by mechanical means;
- .2 has no system, equipment and/or machinery fitted that may generate emissions regulated by this Section; and

- .3 has neither persons nor living animals on board.

7.1.2.27 Gas fuel – means a fuel oil with a vapour pressure exceeding 0.28 MPa absolute at a temperature of 37.8°C.

7.1.2.28 Fluorinated greenhouse gases – means the substances listed in Annexes I, II and III of Regulation (EU) 2024/573 or mixtures containing any of those substances.

7.1.3 Exceptions and Exemptions

7.1.3.1 General

Regulations of this Section of the *Rules* shall not apply to:

- .1 any emission necessary for the purpose of securing the safety of a ship or saving life at sea; or
- .2 any emission resulting from damage to a ship or its equipment:
 - .1 provided that all reasonable precautions have been taken after the occurrence of the damage or discovery of the emission for the purpose of preventing or minimising the emission; and
 - .2 except if the owner or the master acted either with intent to cause damage, or recklessly and with knowledge that damage would probably result.

7.1.3.2 Trials for Ship Emission Reduction and Control Technology Research

The Administration may, in co-operation with other Administrations as appropriate, issue an exemption from specific provisions of this Section for a ship to conduct trials for the development of ship emission reduction and control technologies and engine design programmes. Such an exemption shall only be provided if the applications of specific provisions of this Section or the *NOx Technical Code 2008* could impede research into the development of such technologies or programmes. A permit for such an exemption shall only be provided to the minimum number of ships necessary and be subject to the following provisions:

- .1 for marine diesel engines with a per cylinder displacement up to 30 litres, the duration of the sea trial shall not exceed 18 months. If additional time is required, the Administration or the permitting Administrations may permit a renewal for one additional 18-month period; or
- .2 for marine diesel engines with a per cylinder displacement at or above 30 litres, the duration of the ship trial shall not exceed 5 years and shall require a progress review by the Administration or the permitting Administrations at each intermediate survey. A permit may be withdrawn based on this review if the testing has not adhered to the conditions of the permit or if it is determined that the technology or programme is not likely to produce effective results in the reduction and control of ship emissions. If the Administration or the reviewing Administration determine that additional time is required to conduct a test of a particular

technology or programme, a permit may be renewed for an additional time period not to exceed five years.

7.1.3.3 Emissions from Sea-bed Mineral Activities

Emissions directly arising from the exploration, exploitation and associated offshore processing of sea-bed mineral resources are exempt from the provisions of this Section. Such emissions include the following:

- .1 emissions resulting from the incineration of substances that are solely and directly the result of exploration, exploitation and associated offshore processing of sea-bed mineral resources, including but not limited to the flaring of hydrocarbons and the burning of cuttings, muds, and/or stimulation fluids during well completion and testing operations, and flaring arising from upset conditions;
- .2 the release of gases and volatile compounds entrained in drilling fluids and cuttings;
- .3 emissions associated solely and directly with the treatment, handling, or storage of sea-bed minerals; and
- .4 emissions from marine diesel engines that are solely dedicated to the exploration, exploitation and associated offshore processing of sea-bed mineral resources.

The requirements of 7.3.6 shall not apply to the use of hydrocarbons which are produced and subsequently used on site as fuel.

7.1.3.4 Unmanned non-self-propelled barges

The Administration may exempt an unmanned non-self-propelled (UNSP) barge from the requirements of stated in 7.2.1 and 7.2.2 of this Section by means of an International Air Pollution Prevention Exemption Certificate for Unmanned Non-self-propelled (UNSP) Barges, for a period not exceeding five years provided that the barge has undergone a survey to confirm that conditions referred to in item 7.1.2.26 of this Section are met.

Guidelines for the exemption of unmanned non-self-propelled barges from certain survey and certification requirements under the MARPOL Convention are given in MEPC.1/Circ.892. In addition to requirements stated in MEPC.1/Circ.892, specific requirements of the Administration should also be followed, if any.

7.1.4 Equivalents

7.1.4.1 The *Administration* may allow any fitting, material, appliance or apparatus to be fitted in a ship or other procedures, alternative fuel oils, or compliance methods used as an alternative to that required by this of if such fitting, material, appliance or apparatus or other procedures, alternative fuel oils, or compliance methods are at least as effective in terms of emissions reductions as that required by this Section, including any of the standards set forth in 7.3.2 and 7.3.3.

7.1.4.2 The *Administration* which allows a fitting, material, appliance or apparatus or other procedures, alternative fuel oils, or compliance methods used as an alternative to that required by this Section shall communicate to the IMO for circulation to the Parties particulars thereof, for their information and appropriate action, if any.

7.1.4.3 The *Administration* should take into account any relevant guidelines developed by the IMO pertaining to the equivalents provided for in this regulation 7.1.4.

7.1.4.4 The *Administration* which allows the use of an equivalent as set forth in 7.1.4.1 shall endeavour not to impair or damage its environment, human health, property, or resources or those of other States.

7.1.4.5 Guidelines for exhaust gas cleaning systems are set out in IMO Res. MEPC.340(77) – 2021 *Guidelines for exhaust gas cleaning systems*.

7.1.4.6 Guidelines for thermal waste treatment devices are set out in IMO Res. MEPC.373(80) – 2023 *Guidelines for thermal waste treatment devices (TWTDD)*.

7.2 SURVEY, CERTIFICATION AND MEANS OF CONTROL

This Section states the requirements specific to the prevention of air pollution from ships.

7.2.1 Surveys

7.2.1.1 Every ship of 400 gross tonnage or above and every fixed and floating drilling rig and other platforms shall be subject to the surveys specified below:

- .1 **Initial survey** – before the ship is put into service or before the certificate required under 7.2.2 is issued for the first time. This survey shall be such as to ensure that the equipment, systems, fittings, arrangements and material fully comply with the applicable requirements of this Section;
- .2 **Renewal survey** – at intervals of five years, except where 7.2.3.2, 7.2.3.4 or 7.2.3.5 is applicable. The renewal survey shall be such as to ensure that the equipment, systems, fittings, arrangements and material fully comply with applicable requirements of this Section;
- .3 **Intermediate survey** – within three months before or after the second anniversary date or within three months before or after the third anniversary date of the certificate which shall take the place of one of the annual surveys specified in 7.2.1.1-.4.4. The intermediate survey shall be such as to ensure that the equipment and arrangements fully comply with the applicable requirements of this Section and are in good working order. Such intermediate surveys shall be endorsed on the certificate issued under 7.2.2.
- .4 **Annual survey** – within three months before or after each anniversary date of the certificate, including a general inspection of the equipment, systems, fittings, arrangements and material referred to in 7.2.1.1-1 to ensure that they have been maintained in accordance with 7.2.1.3 and that they remain satisfactory for the service for which the ship is intended. Such

annual surveys shall be endorsed on the certificate issued under 7.2.2; and

- 5 **Additional survey** – either general or partial, according to the circumstances, shall be made whenever any important repairs or renewals are made as prescribed in 7.2.1.3 or after a repair resulting from investigations prescribed in 7.2.1.4. The survey shall be such as to ensure that the necessary repairs or renewals have been effectively made, that the material and workmanship of such repairs or renewals are in all respects satisfactory and that the ship complies in all respects with the requirements of this Section.

7.2.1.2 All marine diesel engines over 130 kW, except those exempted by 7.1.3 or 7.3.2, are to comply with the 7.3.2 limit regardless of the gross tonnage of the ship onto which the engine is installed. In this context such engines must have an approved *Technical File* and must be issued with an EIAPP certificate in accordance with the *NOx Technical Code* in all cases.

Ship surveys specified in 7.2 do not apply to ships under 400 GT.

7.2.1.3 Ship surveys specified in 7.4.4 do not apply to ships engaged on voyages within area of navigation 5 to 8 constructed before 1st January 2018, and to marine diesel engines installed onboard these ships before 1st January 2018.

7.2.1.4 The equipment shall be maintained to conform with the provisions of this Section and no changes shall be made in the equipment, systems, fittings, arrangements, or material covered by the survey, without the express approval of the *Register*. The direct replacement of such equipment and fittings with equipment and fittings that conform with the provisions of this Section is permitted.

7.2.1.5 Whenever an accident occurs to a ship or a defect is discovered which substantially affects the efficiency or completeness of its equipment covered by this Section, the master or owner of the ship shall report at the earliest opportunity the *Register* responsible for issuing the relevant certificate.

7.2.2 Issue or endorsement of a Certificate

7.2.2.1 An *International Air Pollution Prevention Certificate* (i.e. *IAPP Certificate*) shall be issued after initial or renewal survey in accordance with the provisions of 7.2.1, to:

- .1 any ship of 400 gross tonnage or above engaged in voyages to ports or offshore terminals under the jurisdiction of other Parties to the Protocol of 1997; and
- .2 platforms and drilling rigs engaged in voyages to waters under the sovereignty or jurisdiction of other Parties to the Protocol of 1997.

7.2.2.2 A ship constructed before the date of entry into force of Annex VI shall be issued with an *International Air Pollution Prevention Certificate* in accordance with 7.2.2.1 no later than the first scheduled dry-docking after the date of such entry into force, but in no case later than three years after this date.

7.2.3 Duration and validity of Certificate

7.2.3.1 An *International Air Pollution Prevention Certificate* is issued for a period of five years.

7.2.3.2 Notwithstanding the requirements of 7.2.3.1:

- .1 when the renewal survey is completed within three months before the expiry date of the existing certificate, the new certificate shall be valid from the date of completion of the renewal survey to a date not exceeding five years from the date of expiry of the existing certificate;
- .2 when the renewal survey is completed after the expiry date of the existing certificate, the new certificate shall be valid from the date of completion of the renewal survey to a date not exceeding five years from the date of expiry of the existing certificate; and
- .3 when the renewal survey is completed more than three months before the expiry date of the existing certificate, the new certificate shall be valid from the date of completion of the renewal survey to a date not exceeding five years from the date of completion of the renewal survey.

7.2.3.3 If a renewal survey has been completed and a new certificate cannot be issued or placed on board the ship before the expiry date of the existing certificate, the *Register* may endorse the existing certificate and such a certificate shall be accepted as valid for a further period which shall not exceed five months from the expiry date.

7.2.3.4 If a ship, at the time when a certificate expires, is not in a port in which it is to be surveyed, the *Register* may extend the period of validity of the certificate but this extension shall be granted only for the purpose of allowing the ship to complete its voyage to the port in which it is to be surveyed, and then only in cases where it appears proper and reasonable to do so. No certificate shall be extended for a period longer than three months, and a ship to which an extension is granted shall not, on its arrival in the port in which it is to be surveyed, be entitled by virtue of such extension to leave that port without having a new certificate. When the renewal survey is completed, the new certificate shall be valid to a date not exceeding five years from the date of expiry of the existing certificate before the extension was granted.

7.2.3.5 A certificate issued to a ship engaged on short voyages which has not been extended under the foregoing provisions of 7.2.3 may be extended by the *Register* for a period of grace of up to one month from the date of expiry stated on it. When the renewal survey is completed, the new certificate shall be valid to a date not exceeding five years from the date of expiry of the existing certificate before the extension was granted.

7.2.3.6 If an annual or intermediate survey is completed before the period specified in 7.2.1, then:

- .1 the anniversary date shown on the certificate shall be amended by endorsement to a date which shall not be more than three months later than the date on which the survey was completed;

- .2 the subsequent annual or intermediate survey required by 7.2.1 shall be completed at the intervals prescribed by 7.2.1 using the new anniversary date; and
- .3 the expiry date may remain unchanged provided one or more annual or intermediate surveys, as appropriate, are carried out so that the maximum intervals between the surveys prescribed by 7.2.1 are not exceeded.

7.2.3.7 A certificate issued under 7.2.2 shall cease to be valid in any of the following cases:

- .1 if the relevant surveys are not completed within the periods specified under 7.2.1.1;
- .2 if the certificate is not endorsed in accordance with 7.2.1.1-.3 or 7.2.1.1-.4; and
- .3 upon transfer of the ship to the flag of another State.

7.2.4 International Air Pollution Prevention Exemption Certificate for Unmanned Non-self-propelled Barges

In accordance with 7.1.3.4, the International Air Pollution Prevention Exemption Certificate for Unmanned Non-self-propelled Barges shall be drawn up in the form corresponding to the model given in appendix XI of Annex VI of IMO Res. MEPC.328(76) and shall be at least in English, French or Spanish. If an official language of the issuing country is also used, this shall prevail in the event of a dispute or discrepancy.

7.3 REQUIREMENTS FOR CONTROL OF EMISSIONS FROM SHIPS

7.3.1 Ozone-depleting substances

7.3.1.1 Item 7.3.1 does not apply to permanently sealed equipment where there are no refrigerant charging connections or potentially removable components containing ozone depleting substances.

7.3.1.2 Subject to the provisions of 7.1.3.1, any deliberate emissions of ozone depleting substances shall be prohibited. Deliberate emissions include emissions occurring in the course of maintaining, servicing, repairing or disposing of systems or equipment, except that deliberate emissions do not include minimal releases associated with the recapture or recycling of an ozone depleting substance. Emissions arising from leaks of an ozone depleting substance, whether or not the leaks are deliberate, may be regulated by Parties to the Protocol of 1997.

7.3.1.3 Installations which contain ozone depleting substances, other than hydro-chlorofluorocarbons, shall be prohibited:

- .1 on ships constructed on or after 19 May 2005; or
- .2 in the case of ships constructed before 19 May 2005, which have a contractual delivery date of the equipment to the ship on or after 19 May 2005 or, in the absence of a

contractual delivery date, the actual delivery of the equipment to the ship on or after 19 May 2005.

Installations which contain hydro-chlorofluorocarbons shall be prohibited (see also requirements of Regulation (EC) No 1005/2009 of the European parliament and of the Council of 16 September 2009 on substances that deplete the ozone layer):

- .3 on ships constructed on or after 1 January 2020; or
- .4 in the case of ships constructed before 1 January 2020, which have a contractual delivery date of the equipment to the ship on or after 1 January 2020 or, in the absence of a contractual delivery date, the actual delivery of the equipment to the ship on or after 1 January 2020.

7.3.1.4 The substances referred to in 7.3.1, and equipment containing such substances, shall be delivered to appropriate reception facilities when removed from ships.

7.3.1.5 Each ship subject to 7.2.2.1 shall maintain a list of equipment containing ozone depleting substances.

7.3.1.6 Each ship subject to 7.2.2.1 which has rechargeable systems that contain ozone depleting substances shall maintain an *Ozone Depleting Substances Record Book*. This Record Book may form part of an existing log-book or electronic record book as approved by the *Register*.

An electronic recording system referred to in regulation 12.6, as adopted by IMO Res. MEPC.176(58), shall be considered an electronic record book, provided the electronic recording system is approved by the Administration on or before the first International Air Pollution Prevention (IAPP) Certificate renewal survey carried out on or after 1 October 2020, but not later than 1 October 2025, taking into account the Guidelines in IMO Res. MEPC.312(74).

7.3.1.7 Entries in the *Ozone Depleting Substances Record Book* shall be recorded in terms of mass [kg] of substance and shall be completed without delay on each occasion, in respect of the following:

- .1 recharge, full or partial, of equipment containing ozone depleting substances;
- .2 repair or maintenance of equipment containing ozone depleting substances;
- .3 discharge of ozone depleting substances to the atmosphere:
 - .3.1 deliberate; and
 - .3.2 non-deliberate;
- .4 discharge of ozone depleting substances to land-based reception facilities; and
- .5 supply of ozone depleting substances to the ship.

7.3.2 Nitrogen oxides (NO_x)

7.3.2.1 Application

- .1 The item 7.3.2 shall apply to:
 - .1 each marine diesel engine with a power output of more than 130 kW installed on a ship; and

- .2 each marine diesel engine with a power output of more than 130 kW which undergoes a major conversion on or after 1 January 2000 except when demonstrated to the satisfaction of the *Register* that such engine is an identical replacement to the engine which it is replacing and is otherwise not covered under item 7.3.2.1-1.1.
- .2 The item 7.3.2 does not apply to:
 - .1 a marine diesel engine intended to be used solely for emergencies, or solely to power any device or equipment intended to be used solely for emergencies on the ship on which it is installed, or a marine diesel engine installed in lifeboats intended to be used solely for emergencies; and
 - .2 a marine diesel engine installed on a ship solely engaged in voyages within waters subject to the sovereignty or jurisdiction of the State the flag of which the ship is entitled to fly, provided that such engine is subject to an alternative NOx control measure established by the Administration.
- .3 Notwithstanding the provisions of 7.3.2.1-1, the Administration may provide an exclusion from the application of 7.3.2 for any marine diesel engine which is installed on a ship constructed, or for any marine diesel engine which undergoes a major conversion, before 19 May 2005, provided that the ship on which the engine is installed is solely engaged in voyages to ports or offshore terminals within the State the flag of which the ship is entitled to fly.

Note: The term *identical engine* in the sense of the term *identical replacement* is defined as the engine of equal design and model, rated power, rated speed, use, number of cylinders, fuel system type (including, if applicable, injection control software); and

- have the same NOx critical components and settings, for engines without EIAPP certificate, or
- belonging to the same Engine Group / Engine Family, for engines with EIAPP certificate.

In those instances where, at the time of updating the Supplement to the IAPP Certificate (to reflect that engine change) the replaced engine will not be available to be directly compared with the replacing engine, it is to be ensured that the necessary records in respect of the replaced engine are available in order that it can be confirmed that the replacing engine represents an identical engine.

For engines without EIAPP Certification there will not be the defining NOx critical component markings or setting values as usually

given in the approved Technical File. Consequently in these instances the assessment of “*the same NOx critical components and settings*” shall be established on the basis that the following components and settings are the same:

- Fuel system (fuel pump model and injection timing, as well as injection nozzle model);
- Charge air system (configuration and, if applicable, turbocharger model and auxiliary blower specification, as well as cooling medium, i.e. sea water or fresh water).

7.3.2.2 Major Conversion

- .1 For the purpose of 7.3.2, *major conversion* means a modification on or after 1 January 2000 of a marine diesel engine that has not already been certified to the requirements set forth 7.3.2.3, 7.3.2.4 or 7.3.2.5-1.1 where:
 - .1 the engine is replaced by a marine diesel engine or an additional marine diesel engine is installed, or
 - .2 any substantial modification, as defined in the *NOx Technical Code 2008*, is made to the engine, or
 - .3 the maximum continuous rating of the engine is increased by more than 10% compared to the maximum continuous rating of the original certification of the engine.
- .2 For a major conversion involving the replacement of a marine diesel engine with a non-identical marine diesel engine (where non-identical engine is the one not meeting requirements of the Note in item 7.3.2.1), or the installation of an additional marine diesel engine, the requirements in 7.3.2 in force at the time of the replacement or addition of the engine shall apply. For the purpose of 7.3.2, the installation of a marine diesel engine replacing a steam system shall be considered a replacement engine. In the case of replacement engines only, if it is not possible for such a replacement engine to meet the requirements set forth in 7.3.2.5-1.1 (Tier III), then that replacement engine shall meet the requirements set forth in 7.3.2.4 (Tier II), taking into account guidelines in Res. MEPC.386(81). The Administration shall notify the Organization in those instances where a Tier II rather than a Tier III replacement engine has been installed on or after 1 August 2025 in accordance with the provisions of this paragraph.
- .3 A marine diesel engine referred to in 7.3.2.2-1 or 7.3.2.2-2 shall meet the following requirements:
 - .1 for ships constructed prior to 1 January 2000, the requirements set forth in 7.3.2.3 (Tier I) shall apply; and

- .2 for ships constructed on or after 1 January 2000, the requirements in force at the time the ship was constructed shall apply.
- .4 In respect of marine diesel engines installed on or after 1 January 2000 but before 1 July 2010, *major conversion* means a modification of an engine where the engine is replaced (i.e. installed either as a direct replacement for an existing engine, or as an addition to the original engine to meet revised ship requirements) by a new engine built (i.e. engine that left the manufacturer's works for the first time) on or after 1 January 2000.

7.3.2.3 Tier I

Subject to 7.1.3, the operation of a marine diesel engine which is installed on a ship constructed on or after 1 January 2000 and prior to 1 January 2011 is prohibited, except when the emission of nitrogen oxides (calculated as the total weighted emission of NO₂) from the engine is within the following limits:

- 17,0 g/kWh, when $n < 130$ rpm
- $45 \cdot n^{-0.2}$ g/kWh, when $130 \leq n < 2000$ rpm
- 9,8 g/kWh, when $n \geq 2000$ rpm

where:

n – rated engine speed
[crankshaft revolutions per minute].

7.3.2.4 Tier II

Subject to 7.1.3, the operation of a marine diesel engine which is installed on a ship constructed on or after 1 January 2011 is prohibited, except when the emission of nitrogen oxides (calculated as the total weighted emission of NO₂) from the engine is within the following limits:

- 14,4 g/kWh, when $n < 130$ rpm
- $44 \cdot n^{-0.23}$ g/kWh, when $130 \leq n < 2000$ rpm
- 7,7 g/kWh, when $n \geq 2000$ rpm

where:

n – rated engine speed
[crankshaft revolutions per minute].

7.3.2.5 Tier III

- .1 Subject to 7.1.3, the operation of a marine diesel engine which is installed on a ship in an emission control area is prohibited except:

when the emission of nitrogen oxides (calculated as the total weighted emission of NO₂) from the engine is within the following limits:

- 3,4 g/kWh, when $n < 130$ rpm
- $9 \cdot n^{-0.2}$ g/kWh, when $130 \leq n < 2000$ rpm
- 7,7 g/kWh, when $n \geq 2000$ rpm

where:

n – rated engine speed
[crankshaft revolutions per minute],
when ship is operating in an emission control area, and is constructed on or after the date of adoption of such an emission control area, or a later date as may be specified in the amendment

designating the NO_x Tier III emission control area, whichever is later.

Ships constructed on or after 1 January 2016 and operating in the North American Emission Control Area or the US Caribbean Sea Emission Control Area and ships constructed on or after 1st January 2021 and operating in the Baltic sea and North sea emission control area, are to comply with the emission limits in 7.3.2.5-1.1.

Ships constructed on or after 1 March 2026 and operating in the Norwegian Sea Emission Control Area and ships constructed on or after 1st January 2025 and operating in the Canadian Arctic emission control area, are to comply with the emission limits in 7.3.2.5-1.1.

- .2 The standards set forth in 7.3.2.5-1.1 shall not apply to:

- .1 a marine diesel engine installed on a ship with a length L , as defined in 2.1.2.26, less than 24 metres when it has been specifically designed, and is used solely, for recreational purposes; or
- .2 a marine diesel engine installed on a ship with a combined nameplate diesel engine propulsion power of less than 750 kW if it is demonstrated, to the satisfaction of the *Register*, that the ship cannot comply with the standards set forth in 7.3.2.5-1.1 because of design or construction limitations of the ship, or
- .3 a marine diesel engine installed on a ship constructed prior to 1 January 2021 of less than 500 gross tonnage, with a length L , as defined in 2.1.2.26 of 24 metres or over, when it has been specifically designed, and is used solely, for recreational purposes.

- .3 The tier and on/off status of marine diesel engines installed onboard a ship to which 7.3.2.5.1 applies which are certified to both Tier II and Tier III or which are certified to Tier II only shall be recorded in such logbook or electronic record book as prescribed by the Administration at entry into and exit from an emission control area designated under 7.3.2.6, or when the on/off status changes within such an area, together with date, time and position of the ship.

7.3.2.6 Emission Control Area

For the purpose of 7.3.2, an Emission Control Area shall be any sea area, including any port area, designated by the IMO in accordance with the criteria and procedures set forth in Appendix III to the IMO Res. MEPC.328(76).

7.3.2.7 Marine Diesel Engines Installed on a Ship Constructed Prior to 1st January 2000

- .1 Notwithstanding 7.3.2.1-1.1, a marine diesel engine with a power output of more than 5000 kW and a per cylinder displacement at or above 90 litres installed on a

ship constructed on or after 1st January 1990 but prior to 1st January 2000 shall comply with the emission limits set forth in 7.3.2.7-4, provided that an Approved Method for that engine has been certified by an Administration of a Party to the Protocol of 1997 and notification of such certification has been submitted to the IMO by the certifying Administration. Compliance with this paragraph shall be demonstrated through one of the following:

- .1 installation of the certified Approved Method, as confirmed by a survey using the verification procedure specified in the Approved Method File, including appropriate notation on the ship's International Air Pollution Prevention Certificate of the presence of the Approved Method; or
 - .2 certification of the engine confirming that it operates within the limits set forth in 7.3.2.3, 7.3.2.4 or 7.3.2.5-1.1 and an appropriate notation of the engine certification on the ship's International Air Pollution Prevention Certificate.
- 2 Subitem 7.3.2.7-1 shall apply no later than the first renewal survey that occurs 12 months or more after deposit of the notification in 7.3.2.7-1. If a shipowner of a ship on which an Approved Method is to be installed can demonstrate to the satisfaction of the *Register* that the Approved Method was not commercially available despite best efforts to obtain it, then that Approved Method shall be installed on the ship no later than the next annual survey of that ship which falls after the Approved Method is commercially available.
- 3 With regard to a ship with a marine diesel engine with a power output of more than 5000 kW and a per cylinder displacement at or above 90 litres installed on a ship constructed on or after 1st January 1990 but prior to 1st January 2000, the International Air Pollution Prevention Certificate shall, for a marine diesel engine to which 7.3.2.7-1 applies, indicate that either an Approved Method has been applied pursuant to 7.3.2.7-1.1 or the engine has been certified pursuant to 7.3.2.7-1.2 or that an Approved Method is not applicable or is not yet commercially available as described in 7.3.2.7-2.
- 4 Subject to 7.1.3, the operation of a marine diesel engine described in 7.3.2.7-1 is prohibited, except when the emission of nitrogen oxides (calculated as the total weighted emission of NO₂) from the engine is within the following limits:
 17,0 g/kWh, when $n < 130$ rpm
 $45 \cdot n^{-0.2}$ g/kWh, when $130 \leq n < 2000$ rpm
 9,8 g/kWh, when $n \geq 2000$ rpm

where:

n – rated engine speed
 [crankshaft revolutions per minute].

- 5 Certification of an Approved Method shall be in accordance with 7.4.13 and shall include verification:
- .1 by the designer of the base marine diesel engine to which the Approved Method applies that the calculated effect of the Approved Method will not decrease engine rating by more than 1,0%, increase fuel consumption by more than 2,0% as measured according to the appropriate test cycle set forth in 7.4.9, or adversely affect engine durability or reliability; and
 - .2 that the cost of the Approved Method is not excessive, which is determined by a comparison of the amount of NO_x reduced by the Approved Method to achieve the standard set forth in 7.3.2.7-4 and the cost of purchasing and installing such Approved Method.

Note: The cost of an Approved Method C_e shall not exceed 375 Special Drawing Rights/metric ton NO_x calculated in accordance with the Cost-Effectiveness formula below:

$$C_e = \frac{\text{Cost of approved method} \cdot 10^6}{P[\text{kW}] \cdot 0,768 \cdot 6000[\text{h/year}] \cdot 5[\text{years}] \cdot \Delta NO_x[\text{g/kWh}]}$$

7.3.2.8 Certification

The *NO_x Technical Code 2008* shall be applied in the certification, testing, and measurement procedures for the standards set forth in 7.3.2.

7.3.2.9 The procedures for determining NO_x emissions set out in the *NO_x Technical Code 2008* are intended to be representative of the normal operation of the engine. Defeat devices and irrational emission control strategies undermine this intention and shall not be allowed. Requirements of 7.3.2 shall not prevent the use of auxiliary control devices that are used to protect the engine and/or its ancillary equipment against operating conditions that could result in damage or failure or that are used to facilitate the starting of the engine.

7.3.3 Sulphur Oxides (SO_x) and Particulate Matter

General Requirements

7.3.3.1 The sulphur content of fuel oil used or carried for use on board ships shall not exceed 0,50% m/m.

7.3.3.2

- .1 The worldwide average sulphur content of residual fuel oil supplied for use on board ships shall be monitored taking into account guidelines developed by the IMO (see resolution MEPC.192(61) *Guidelines for Monitoring the World-wide Average Sulphur Content of Fuel Oils Supplied for Use On Board Ships*, as amended by Res.MEPC.273(69)).
- .2 Intentionally blank.

- .3 On ships at berth in EU ports, except on ships with published timetables which are due to be at berth for less than two hours, fuel oils with a sulphur content exceeding 0,1% by mass shall not be used. In that respect, it is necessary to complete fuel change-over operation as soon as possible after arrival at berth and as late as possible before departure. This shall not apply to ships which at berth in EU ports switch off all engines and use shoreside electricity.

Requirements within Emission Control Areas

7.3.3.3 For the purpose of 7.3.3 Emission Control Areas shall include:

- .1 the Baltic Sea area as defined in MARPOL 73/78 Convention, Annex I, regulation 1.11.2, the North Sea as defined in MARPOL 73/78 Convention, Annex V, regulation 1.14.6;
- .2 the North American ECA and the US Caribbean sea ECA, which means the areas described by the coordinates provided in Appendix VII to the MARPOL Annex VI;
- .3 the Mediterranean Sea ECA, which means the area described by the coordinates provided in Appendix VII to the MARPOL Annex VI;
- .4 the Canadian Arctic ECA, which means the area described by the coordinates provided in Appendix VII to the MARPOL Annex VI;
- .5 the Norwegian Sea as defined in MARPOL 73/78 Convention, Annex II, regulation 13.9.4;
- .6 any other sea area, including port areas, designated by the IMO in accordance with criteria and procedures set forth in Appendix III to the MARPOL Annex VI.

7.3.3.4 While ships are operating within an Emission Control Area, the sulphur content of fuel oil used on board ships shall not exceed 0,10% m/m.

7.3.3.5 The sulphur content of fuel oil referred to in 7.3.3.1 and 7.3.3.4 shall be documented by its supplier as required by 7.3.6.

7.3.3.6 Those ships using separate fuel oils to comply with 7.3.3.4 and entering or leaving an Emission Control Area set forth in 7.3.3.3 shall carry a written procedure showing how the fuel oil change-over is to be done, allowing sufficient time for the fuel oil service system to be fully flushed of all fuel oils exceeding the applicable sulphur content specified in 7.3.3.4 prior to entry into an Emission Control Area. The volume of low sulphur fuel oils in each tank as well as the date, time, and position of the ship when any fuel-oil-change-over operation is completed prior to the entry into an Emission Control Area or commenced after exit from such an area, shall be recorded in such log-book or electronic record book as prescribed by the Administration.

7.3.3.7 During the first twelve months immediately following an amendment designating a specific Emission Control Area under 7.3.3.3-.2, ships operating in that Emission Control Area are exempt from the requirements in 7.3.3.4 and 7.3.3.6 and from the requirements of 7.3.3.5 insofar as they relate to 7.3.3.4.

7.3.3.8 If the competent authority of a Party requires the in-use or onboard sample to be analysed, it shall be done in accordance with the verification procedure set forth in appendix VI to MARPOL Annex VI to determine whether the fuel oil being used or carried for use on board meets the requirements in 7.3.3.1 and in 7.3.3.4. The in-use sample shall be drawn taking into account the guidelines in MEPC.1/Circ.864/Rev.1. The onboard sample shall be drawn taking into account the guidelines in MEPC.1/Circ.889.

7.3.3.9 The sample shall be sealed by the representative of the competent authority with a unique means of identification installed in the presence of the ship's representative. The ship shall be given the option of retaining a duplicate sample.

7.3.3.10 From 1 April 2022 for each ship of 400 gross tonnage and above, sampling point(s) shall be fitted or designated for the purpose of taking representative samples of the fuel oil being used on board the ship taking into account the guidelines in MEPC.1/Circ.864/Rev.1.

7.3.3.11 For a ship constructed before 1 April 2022, the sampling point(s) referred to in 7.3.3.10 shall be fitted or designated not later than the first IAPPC renewal survey on or after 1 April 2023.

7.3.3.12 The requirements of 7.3.3.10 and 7.3.3.11 above are not applicable to a fuel oil service system used for a low-flashpoint fuel or a gas fuel.

7.3.3.13 The competent authority of a Party shall, as appropriate, utilize the sampling point(s) which is(are) fitted or designated for the purpose of taking representative sample(s) of the fuel oil being used on board in order to verify that the fuel oil complies with 7.3.3. Taking fuel oil samples by the competent authority of the Party shall be performed as expeditiously as possible without causing the ship to be unduly delayed.

7.3.4 Volatile Organic Compounds (VOCs)

7.3.4.1 If the emissions of VOCs from a tanker are to be regulated in a port or ports or a terminal or terminals under the jurisdiction of a Party to the Protocol of 1997, 7.3.4.2 and 7.3.4.3 are applied.

7.3.4.2 A tanker to which 7.3.4.1 applies shall be provided with a vapour emission collection system approved by the *Register* taking into account the safety standards for such systems developed by the IMO (MSC/Circ.585 *Standards for vapour emission control systems*), and shall use this system during the loading of relevant cargoes.

7.3.4.3 A tanker carrying crude oil shall have on board and implement a VOC Management Plan approved by the *Register*. Such a plan shall be prepared taking into account the guidelines in the IMO Res. MEPC.185(59) and the circular MEPC.1/Circ. 680. The plan shall be specific to each ship and shall at least:

- .1 provide written procedures for minimising VOC emissions during the loading, sea passage and discharge of cargo;
- .2 give consideration to the additional VOC generated by crude oil washing;
- .3 identify a person responsible for implementing the plan; and

- .4 for ships on international voyages, be written in the working language of the master and officers and, if the working language of the master and officers is not English, French, or Spanish, include a translation into one of these languages.

7.3.5 Shipboard incineration

7.3.5.1 Except as provided in 7.3.5.4, shipboard incineration shall be allowed only in a shipboard incinerator.

7.3.5.2 Shipboard incineration of the following substances shall be prohibited:

- .1 residues of cargoes subject to MARPOL 73/78 Convention, Annex I, II or III or related contaminated packing materials;
- .2 polychlorinated biphenyls (PCBs);
- .3 garbage, as defined by MARPOL 73/78 Convention, Annex V, containing more than traces of heavy metals;
- .4 refined petroleum products containing halogen compounds;
- .5 sewage sludge and sludge oil either of which are not generated on board the ship; and
- .6 exhaust gas cleaning system residues.

7.3.5.3 Shipboard incineration of polyvinyl chlorides (PVCs) shall be prohibited, except in shipboard incinerator for which an IMO Type Approval Certificate, in accordance with IMO Res. MEPC.59(33) or IMO Res. MEPC.76(40), or IMO Res. MEPC.244(66) has been issued.

7.3.5.4 Shipboard incineration of sewage sludge and sludge oil generated during normal operation of a ship may also take place in the main or auxiliary power plant or boilers, but in those cases, shall not take place inside ports, harbours and estuaries.

7.3.5.5 Nothing in 7.3.5 either:

- .1 affects the prohibition in, or other requirements of, the *Convention on the Prevention of Marine Pollution by Dumping of Wastes and Other Matter, 1972*, as amended, and the *1996 Protocol* thereto, or
- .2 precludes the development, installation and operation of alternative design shipboard thermal waste treatment devices that meet or exceed the requirements of 7.3.5.

7.3.5.6 Each incinerator on a ship constructed on or after 1 January 2000 shall meet the requirements contained in appendix IV to the IMO Res. MEPC.328(76). Each incinerator subject to this sub-item shall be approved by the *Register* taking into account the standard specification for shipboard incinerators developed by the IMO (refer to IMO Res. MEPC.76(40)); or

7.3.5.7 Incinerators installed in accordance with the requirements of 7.3.5.6 shall be provided with a manufacturer's operating manual which is to be retained with the unit and which shall specify how to operate the incinerator within the limits described in paragraph 2 of appendix IV to the IMO Res. MEPC.328(76).

7.3.5.8 Personnel responsible for the operation of an incinerator installed in accordance with the requirements of 7.3.5.6-1 shall be trained to implement the guidance provided in the manufacturer's operating manual as required by 7.3.5.7.

7.3.5.9 For incinerators installed in accordance with the requirements of 7.3.5.6-1 the combustion chamber gas outlet temperature shall be monitored at all times the unit is in operation. Where that incinerator is of the continuous-feed type, waste shall not be fed into the unit when the combustion chamber gas outlet temperature is below 850°C. Where that incinerator is of the batch-loaded type, the unit shall be designed so that the combustion chamber gas outlet temperature shall reach 600°C within five minutes after start-up and will thereafter stabilise at a temperature not less than 850°C.

7.3.6 Fuel oil quality

7.3.6.1 Fuel oil delivered to and used on board ships to which this Section applies shall meet the following requirements:

- .1 except as provided in 7.3.6.1-.2:
 - .1 the fuel oil shall be blends of hydrocarbons derived from petroleum refining. This shall not preclude the incorporation of small amounts of additives intended to improve some aspects of performance;
 - .2 the fuel oil shall be free from inorganic acid; and
 - .3 the fuel oil shall not include any added substance or chemical waste which:
 - .1 jeopardises the safety of ships or adversely affects the performance of the machinery, or
 - .2 is harmful to personnel, or
 - .3 contributes overall to additional air pollution.
- .2 fuel oil derived by methods other than petroleum refining shall not:
 - .1 exceed the applicable sulphur content set forth in 7.3.3;
 - .2 cause an engine to exceed the applicable NO_x emission limit set forth in paragraphs 7.3.2.3, 7.3.2.4, 7.3.2.5-1.1 and 7.3.2.7-4;
 - .3 contain inorganic acid; or
 - .4 jeopardise the safety of ships or adversely affect the performance of the machinery, or
 - .5 be harmful to personnel, or
 - .6 contribute overall to additional air pollution.

7.3.6.2 Sub-items 7.3.6.3 and 7.3.6.4 are applicable to all ships of 400 GT or above.

Item 7.3.6 does not apply to coal in its solid form or nuclear fuels.

Sub-items 7.3.6.3.1 and 7.3.6.5 do not apply to low-flashpoint fuels or gas fuels.

7.3.6.3.1 For each ship subject to 7.2.1 and 7.2.2, details of fuel oil delivered to and used on board that ship shall be recorded by means of a bunker delivery note which shall

contain at least the information specified in appendix V to the IMO Res. MEPC.328(76).

7.3.6.3.2 For each ship subject to 7.2.1 and 7.2.2, details of low-flashpoint fuel or gas fuel delivered to and used on board that ship shall be recorded by means of a bunker delivery note that shall include at least the information specified in items 1 to 6 of appendix V to the IMO Res. MEPC.328(76), the density as determined by a test method appropriate to the fuel type together with the associated temperature and a declaration signed and certified by the fuel oil supplier's representative that the fuel oil is in conformity with 7.3.6.1. In addition the sulphur content of a low-flashpoint fuel or a gas fuel delivered to a ship specifically for use on board that ship shall be documented on the bunker delivery note by the supplier in terms of either the actual value as determined by a test method appropriate to the fuel type or, with the agreement of the appropriate authority at the port of supply, a statement that the sulphur content, when tested by such a method, is less than 0.001% m/m.

7.3.6.4 The bunker delivery note shall be kept on board the ship in such a place as to be readily available for inspection at all reasonable times. It shall be retained for a period of three years after the fuel oil has been delivered on board.

Regulation in 7.3.6.3 and 7.3.6.4 is applicable to all ships of 400 gross tonnage or above and, at the Administration discretion, for ships of less than 400 gross tonnage.

7.3.6.5 The bunker delivery note shall be accompanied by a representative sample of the fuel oil delivered taking into account guidelines developed by the IMO (refer to IMO Res. MEPC.182(59) *Guidelines for the Sampling of Fuel Oil for Determination of Compliance with Annex VI of MARPOL 73/78*). The sample is to be sealed and signed by the supplier's representative and the master or officer in charge of the bunker operation on completion of bunkering operations. The sample is to be retained under the ship's control until the fuel oil is substantially consumed, but in any case for a period of not less than 12 months from the time of delivery.

7.4 REQUIREMENTS OF NO_x TECHNICAL CODE 2008

7.4.1 Introduction and purpose

7.4.1.1 As general background information, the precursors to the formation of nitrogen oxides during the combustion process are nitrogen and oxygen. Together these compounds comprise 99% of the engine intake air. Oxygen will be consumed during the combustion process, with the amount of excess oxygen available being a function of the air/fuel ratio which the engine is operating under.

The nitrogen remains largely unreacted in the combustion process; however, a small percentage will be oxidised to form various oxides of nitrogen. The nitrogen oxides (NO_x) which can be formed include nitric oxide (NO) and nitrogen dioxide (NO₂), while the amounts are primarily a function of flame or combustion temperature and, if present, the amount of organic nitrogen available from the fuel. NO_x formation is also a function of the time the nitrogen and the excess oxygen are exposed to the high temperatures associated with the diesel engine's combustion process. In other words,

the higher the combustion temperature (e.g., high-peak pressure, high-compression ratio, high rate of fuel delivery, etc.), the greater the amount of NO_x formation. A slow-speed diesel engine, in general, tends to have more NO_x formation than a high speed engine.

NO_x has an adverse effect on the environment causing acidification, formation of tropospheric ozone, nutrient enrichment and contributes to adverse health effects globally.

7.4.1.2 The purpose of *Technical Code on Control of Emission of Nitrogen Oxides from Marine Diesel Engines*, hereunder referred to as the *NO_x Technical Code 2008*, is to provide mandatory procedures for the testing, survey and certification of marine diesel engines which will enable engine manufacturers, shipowners and Administrations to ensure that all applicable marine diesel engines comply with the relevant limiting emission values of NO_x as specified 7.3.2.

The difficulties of establishing with precision, the actual weighted average NO_x emission of marine diesel engines in service on ships have been recognised in formulating a simple, practical set of requirements in which the means to ensure compliance with the allowable NO_x emissions are defined.

7.4.1.3 Administrations are encouraged to assess the emissions performance of marine propulsion and auxiliary diesel engines on a test bed, where accurate tests can be carried out under properly controlled conditions.

Establishing compliance with 7.3.2 at this initial stage is an essential feature of the *NO_x Technical Code 2008*. Subsequent testing on board the ship may inevitably be limited in scope and accuracy. Its purpose shall be to infer or deduce the emission performance and to confirm that engines are installed, operated and maintained in accordance with the manufacturer's specifications and that any adjustments or modifications do not detract from the emissions performance established by initial testing and certification by the manufacturer.

7.4.2 Application

7.4.2.1 *NO_x Technical Code 2008* applies to all marine diesel engines with a power output of more than 130 kW which are installed, or are designed and intended for installation, on board any ship subject to Section 7 and to which 7.3.2 applies. Regarding the requirements for survey and certification under 7.2.1, this Code addresses only those requirements applicable to an engine's compliance with the NO_x emission limits.

7.4.2.2 For the purpose of the application of the *NO_x Technical Code 2008*, Administrations are entitled to delegate all functions required of an Administration by this Code to a Recognised Organisation (RO), i.e. an organisation authorised to act on behalf of the Administration (refer to the IMO resolutions A.739(18) *Guidelines for the Authorisation of Organisations Acting on Behalf of Administrations* and A.789(19) *Specifications on the Survey and Certification Functions of Recognised Organisations Acting on Behalf of the Administration*). In every case, the Administration assumes full responsibility for the survey and certificate.

7.4.2.3 For the purpose of the *NO_x Technical Code 2008*, an engine shall be considered to be operated in compliance with the applicable NO_x limit of 7.3.2 if it can be demonstrated that the weighted NO_x emissions from the engine are

within those limits at the initial certification, annual, intermediate and renewal surveys and such other surveys as are required.

7.4.2.4 Amendments in MEPC.397(83) shall enter into effect as follows:

- (a) for a new individual engine or a parent engine of an engine family or engine group that has not been previously certified, the said amendments apply no later than 1 January 2028, based on the issue date of the EIAPP Certificate for the individual engine or parent engine;
- (b) in the case of a new member engine to an engine family or engine group for which the parent engine was certified before 1 January 2028, prior to the certification of that member engine it would need to be shown that the engine family or engine group complied with the said amendments no later than 1 January 2030 based on the issue date of the EIAPP Certificate for that member engine;
- (c) the said amendments do not apply to a marine diesel engine which already has an EIAPP Certificate except:
 - (i) in the case of an engine that is subject to substantial modification on or after 1 January 2028, the said amendments would apply as specified in the definitions of "substantial modification" set out in 7.4.3.2 based on the issue date of the EIAPP Certificate for that engine; and
 - (ii) in the case of an identical replacement engine installed on or after 1 January 2028, the version of the NO_x Technical Code 2008 at the time of issuance of the EIAPP Certificate to the original engine applies, unless the replaced engine is already equipped with multiple engine operational profiles, in which case the provisions of 7.4.16 apply.

7.4.3 Definitions

7.4.3.1 Nitrogen oxide (NO_x) emissions – means the total emission of nitrogen oxides, calculated as the total weighted emission of NO₂ and determined using the relevant test cycles and measurement methods as specified in *NO_x Technical Code 2008*.

7.4.3.2 Substantial modification – of a marine diesel engine means:

- .1 For engines installed on ships constructed on or after 1 January 2000 – any modification to an engine that could potentially cause the engine to exceed the emission standards set out in 7.3.2. Routine replacement of engine components by parts specified in the *Technical File* that do not alter emission characteristics shall not be considered a substantial modification regardless of whether one part or many parts are replaced. For the recertification of such an

engine following a substantial modification, the version of this Code that was used for the original certification shall apply except if the engine was or is now equipped with an auxiliary control device or has multiple engine operational profiles. Where an auxiliary control device is fitted, the requirements of 7.4.8 and 7.4.11 shall apply. Where there are multiple engine operating profiles, the requirements of 7.4.16 shall apply.

- .2 For engines installed on ships constructed before 1 January 2000 – any modification made to an engine which increases its existing emission characteristics established by the *Simplified measurement method* as described in 7.4.14.3 in excess of the allowances set out in 7.4.14.3-4.10. These changes include, but are not limited to, changes in its operations or in its technical parameters (e.g., changing camshafts, fuel injection systems, air systems, combustion chamber configuration, or timing calibration of the engine). The installation of a certified Approved Method pursuant to 7.3.2.7-1.1 or certification pursuant to 7.3.2.7-1.2 is not considered to be a substantial modification for the purpose of the application of 7.3.2.2. For recertification of such an engine following a substantial modification, 7.4.8, 7.4.11 and, where that engine has multiple engine operating profiles, 7.4.16 shall apply.

7.4.3.3 Components – are those interchangeable parts which influence the NO_x emissions performance, identified by their design/parts number.

7.4.3.4 Setting – means adjustment of an adjustable feature influencing the NO_x emissions performance of an engine.

7.4.3.5 Operating values – are engine data, like cylinder peak pressure, exhaust gas temperature, etc., from the engine log which are related to the NO_x emission performance. These data are load-dependent.

7.4.3.6 EIAPP Certificate – is the *Engine International Air Pollution Prevention Certificate* which relates to NO_x emissions.

7.4.3.7 IAPP Certificate – is the *International Air Pollution Prevention Certificate*.

7.4.3.8 Administration – has the same meaning as in article 2, subparagraph (5) of MARPOL 73.

7.4.3.9 On-board NO_x verification procedures – mean a procedure, which may include an equipment requirement, to be used on board at initial certification survey or at the renewal, annual or intermediate surveys, as required, to verify compliance with any of the requirements of *NO_x Technical Code 2008*, as specified by the engine manufacturer and approved by the Administration.

7.4.3.10 Marine diesel engine – means any reciprocating internal-combustion engine operating on liquid or dual fuel, to which 7.3.2 applies, including booster/compound systems if applied.

A gas-fuelled engine installed on a ship constructed on or after 1st March 2016 or a gas-fuelled additional or non-identical replacement engine installed on or after that date is also considered as a marine diesel engine.

Where an engine is intended to be operated normally in the gas mode, i.e. with the gas fuel as the main fuel and with liquid fuel as the pilot or balance fuel, the requirements of 7.3.2 have to be met only for this operation mode. Operation on pure liquid fuel resulting from restricted gas supply in cases of failures shall be exempted for the voyage to the next appropriate port for the repair of the failure.

7.4.3.11 Rated power – means the maximum continuous rated power output as specified on the nameplate and in the *Technical File* of the marine diesel engine to which 7.3.2 and the *NOx Technical Code 2008* apply.

7.4.3.12 Rated speed – is the crankshaft revolutions per minute at which the rated power occurs as specified on the nameplate and in the *Technical File* of the marine diesel engine.

7.4.3.13 Brake power – is the observed power measured at the crankshaft or its equivalent, the engine being equipped only with the standard auxiliaries necessary for its operation on the test-bed.

7.4.3.14 On-board conditions – mean that an engine is:

- .1 installed on board and coupled with the actual equipment which is driven by the engine; and
- .2 under operation to perform the purpose of the equipment.

7.4.3.15 Technical File – is a record containing all details of parameters, including components and settings of an engine, which may influence the NOx emission of the engine, in accordance with 7.4.7.

7.4.3.16 Record book of engine parameters – is the document used in connection with the *Engine Parameter Check Method* for recording all parameter changes, including components and engine settings, which may influence NOx emission of the engine.

7.4.3.17 Approved Method – is a method for a particular engine, or a range of engines, which, when applied to the engine, will ensure that the engine complies with the applicable NOx limit as detailed in 7.3.2.7.

7.4.3.18 Existing Engine – is an engine which is subject to 7.3.2.7.

7.4.3.19 Approved Method File – is a document which describes an Approved Method and its means of survey.

7.4.3.20 Electronic Record Book- means a device or system, approved by the Administration, used to electronically record the entries required under NOx Technical Code in lieu of a hard copy record book.

7.4.3.21 Engine operational profile- means a particular set of NOx influencing settings applied in the base emission control strategy which influences the NOx emission performance. Those settings may relate to, but are not limited to, fuel injection, inlet and exhaust valve operation, charge air management, exhaust bypass/wastegate or exhaust after-treatment controls and auxiliary control devices.

7.4.3.22 Multiple engine operational profiles- means that more than one engine operational profile is available for selection on a marine diesel engine.

7.4.3.23 Auxiliary control device- means a system, function or control strategy installed on a marine diesel engine that is used to protect the engine and/or its ancillary equipment against operating conditions that could result in damage or failure, or that is used to facilitate the starting of the engine. An auxiliary control device may also be a strategy or measure that has been satisfactorily demonstrated not to be a defeat device. An auxiliary control device includes any element of design that includes sensors, or other arrangements which, by an action of the control system, can activate, modulate, delay or deactivate the operation of any part of the base emission control system. Any device or strategy the activation of which causes a non-progressive change in emissions is also an auxiliary control device. An auxiliary control device not declared at the time of the first certification of a marine diesel engine shall be considered a defeat device.

7.4.3.24 Defeat device- means a device that measures, senses or responds to operating variables (e.g. engine speed, temperature, intake pressure or any other parameter) for the purpose of activating, modulating, delaying or deactivating the operation of any component or the function of the emission control system such that the effectiveness of the emission control system is reduced under conditions encountered during normal operation, unless the use of such a device is substantially included in the applied emission certification test procedures. An auxiliary control device accepted as part of the Administration's review of the NOx certification pack is not a defeat device.

7.4.3.25 Base emission control strategy- means the emission control strategy active at any time an auxiliary control device is not active. It consists of any parameter, element of design, or operating control that is designed to modulate as a function of engine load and/or speed in a manner that affects the emission performance of the engine. The modulation of parameters is to be progressive and shall not result in a disproportionate change in emissions.

7.4.3.26 Rational emission control strategy- means the base emission control strategy applied to a marine diesel engine which ensures that the emission values at the individual mode points as used to give the weighted specific emission value are representative of the emission values during normal operation of the engine.

7.4.3.27 Irrational emission control strategy- means any strategy or measure that, when a marine diesel engine is operated under normal conditions of use, reduces the effectiveness of an emission control system to a level below that expected from the applicable emission test procedures.

7.4.3.28 Not-to-exceed emission limit value- means the maximum permitted NOx emission value at a given operating condition as determined in accordance with 7.4.11 within the not-to-exceed zone of the engine.

7.4.3.29 Not-to-exceed zone- means the power or torque and speed area of a marine diesel engine within the limit area of the not-to-exceed zone as declared by the applicant that the engine is certified to operate within under steady-state conditions. In the case of the C1 cycle, as given by 7.4.10, the not-

to-exceed zone corresponds to the whole of the limit area of the not-to-exceed zone.

7.4.3.30 Limit area of the not-to-exceed zone- means the power or torque and speed boundaries of the not-to-exceed zone at and above 25% rated power for all test cycles as given by 7.4.10 except for the C1 cycle where it is at and above 50% engine load.

7.4.3.31 Point emission value- means the NO_x emission value expressed in terms of g/kWh at the reference conditions of humidity and temperature given by this Code at a particular power or load and speed point.

7.4.3.32 NO_x certification pack- means the package of information supplied by the applicant to the Administration as required to be submitted by 7.4.8 and 7.4.11.

7.4.3.33 Propulsion engine- means a marine diesel engine that is used for direct or indirect propulsion. A propulsion engine may additionally perform non-propulsion duties during or separately to propulsion duties.

7.4.3.34 Non-propulsion engine- means a marine diesel engine that is not a propulsion engine. An engine that solely or in part provides athwartships movement of a ship is not a propulsion engine.

7.4.3.35 Constant-speed engine- means a marine diesel engine that is limited to constant-speed operation.

7.4.3.36 Constant-speed engine operation- means a marine diesel engine regulated by a speed control device that automatically controls the operator demand to maintain engine's nominal speed across the load range. In service, such a speed control device may either maintain a fixed speed or a load dependent speed such that at maximum load the speed could be up to around 10% lower than at zero load. Additionally, an idle speed setting may be provided that can be used during start-up or shutdown.

7.4.3.37 Variable-speed engine- means an engine that is not a constant-speed engine.

7.4.4 Surveys and certification in general

7.4.4.1 Each marine diesel engine specified in 7.4.4, except as otherwise permitted by the *NO_x Technical Code 2008*, shall be subject to the following surveys:

- .1 A **pre-certification survey** – which shall be such as to ensure that the engine, as designed and equipped, complies with the NO_x emission limits contained in 7.3.2. If this survey confirms compliance, the Administration shall issue an *Engine International Air Pollution Prevention (EIAPP) Certificate*.
- .2 An **initial certification survey** – which shall be conducted on board a ship after the engine is installed but before it is placed in service. This survey shall be such as to ensure that the engine, as installed on board the ship, including any modifications and/or adjustments since the pre-certification, if applicable, complies with the NO_x emission limits contained in 7.3.2. This survey, as part of the ship's initial survey,

may lead to either the issuance of a ship's initial *International Air Pollution Prevention (IAPP) Certificate* or an amendment of a ship's valid *IAPP Certificate* reflecting the installation of a new engine.

- .3 **Renewal, annual and intermediate surveys** – which shall be conducted as part of a ship's surveys required by 7.2.1, to ensure the engine continues to fully comply with the provisions of the *NO_x Technical Code 2008*.
- .4 An **initial engine's certification survey** – which shall be conducted on board a ship every time a major conversion as defined in 7.3.2.2 is made to an engine to ensure that the engine complies with the NO_x emission limits contained in 7.3.2. This will result in the issue, if applicable, of an EIAPP Certificate and the amendment of the IAPP Certificate.

7.4.4.2 To comply with the survey and certification requirements described in 7.4.4.1, there are methods included in the *NO_x Technical Code 2008* from which the engine manufacturer, ship builder or ship owner, as applicable, can choose to measure, calculate test or verify an engine for its NO_x emissions, as follows:

- .1 **Test-bed testing** for the pre-certification survey in accordance with 7.4.13;
- .2 **On-board testing** for an engine not pre-certified, for a combined pre-certification and initial certification survey in accordance with the full test-bed requirements of 7.4.13;
- .3 **On-board engine parameter check method**, using the component data, engine settings and engine performance data as specified in the *Technical File*, for confirmation of compliance at initial, renewal, annual and intermediate surveys for pre-certified engines or engines that have undergone modifications or adjustments to the NO_x critical components, settings and operating values, since they were last surveyed, in accordance with 7.4.14.2;
- .4 **On-board simplified measurement method** for confirmation of compliance at renewal, annual and intermediate surveys or confirmation of pre-certified engines for initial certification surveys, in accordance with 7.4.14.3; or
- .5 **On-board direct measurement and monitoring** for confirmation of compliance at renewal, annual and intermediate surveys only, in accordance with 7.4.14.4.

7.4.5 Procedures for pre-certification of an engine

7.4.5.1 Prior to installation on board, every marine diesel engine, except as allowed by 7.4.5.2 and 7.4.5.4, shall:

- .1 be adjusted to meet the applicable NO_x emission limits;

- .2 have its NO_x emissions measured on a test-bed in accordance with the procedures specified in 7.4.13; and
- .3 be pre-certified by the Administration, as documented by issuance of an EIAPP Certificate.

7.4.5.2 For the pre-certification of serially manufactured engines, depending on the approval of the Administration, the *Engine Family* or the *Engine Group* concept may be applied (see 7.4.12). In such a case, the testing specified in 7.4.5.1-.2 is required only for the *Parent Engine(s)* of an Engine Family or Engine Group.

7.4.5.3 The method of obtaining pre-certification for an engine is for the Administration to:

- .1 certify a test of the engine on a test-bed;
- .2 verify that all engines tested, including, if applicable, those to be delivered within an Engine Family or the Engine Group, meet the NO_x limits; and
- .3 if applicable, verify that the selected Parent Engine(s) is representative of an Engine Family or the Engine Group.

7.4.5.4

- .1 There are engines which, due to their size, construction and delivery schedule, cannot be pre-certified on a test-bed. In such cases, the engine manufacturer, ship owner or ship builder shall make application to the Administration requesting an on-board test (see 7.4.4.2-.2). The applicant must demonstrate to the Administration that the on-board test fully meets all of the requirements of a test-bed procedure as specified in 7.4.13. In no case shall an allowance be granted for possible deviations of measurements if an initial survey is carried out on board a ship without any valid pre-certification test. For engines undergoing an onboard certification test, in order to be issued with an EIAPP Certificate, the same procedures apply as if the engine had been pre-certified on a test-bed, subject to the limitations given in paragraph 7.4.5.5/.2.
- .2 This pre-certification survey procedure may be accepted for an Individual Engine or for an Engine Group represented by the Parent Engine only, but it shall not be accepted for an Engine Family certification.

7.4.5.5 NO_x reducing devices

- .1 Where a NO_x reducing device is to be included within the EIAPP certification, it must be recognised as a component of the engine and its presence shall be recorded in the engine's Technical File. The applicable test procedure shall be performed and the combined engine/NO_x-reducing device shall be approved and pre-certified by the Administration, taking into account International Maritime Organization resolution [MEPC.399\(83\) 2025 Guidelines on](#)

[selective catalytic reduction \(SCR\) systems](#).

However, the pre-certification in accordance with the procedure not involving the testing for the combined engine/NO_x-reducing device on a test bed as given by the above Guidelines is subject to the limitations given in paragraph 7.4.5.4.2.

Note 1: The gaseous emissions calculation method given in IMO Res. MEPC.399(83) for Scheme A applies to both Scheme A and Scheme B certification of marine diesel engines fitted with selective catalytic reduction (SCR) systems.

Note 2: For guidelines regarding particular requirements related to marine diesel engines fitted with SCR systems see IACS UI MPC 112, MPC 115 and MPC 116.

- .2 In those cases where a NO_x reducing device has been fitted due to failure to meet the required emission value at the pre-certification test, in order to receive an EIAPP Certificate for this assembly, the engine, including the reducing device, as installed, must be re-tested to show compliance with the applicable NO_x emission limit. However, in this case, the assembly may be re-tested in accordance with the Simplified Measurement method in accordance with 7.4.14.3. In no case shall the allowances given in Chapter 6.3.11 of the *NO_x Technical Code 2008* be granted.
- .3 Where, in accordance with 7.4.5.5-.2, the effectiveness of the NO_x reducing device is verified by use of the Simplified Measurement method, that test report shall be added as an adjunct to the pre-certification test report which demonstrated the failure of the engine alone to meet the required emission value. Both test reports shall be submitted to the Administration, and test report data, as detailed in 7.4.7.1-.5, covering both tests shall be included in the engine's Technical File.
- .4 The Simplified Measurement method used as part of the process to demonstrate compliance in accordance with 7.4.5.5-.2 may only be accepted in respect of the engine and NO_x reducing device on which its effectiveness was demonstrated, and it shall not be accepted for Engine Family or Engine Group certification.
- .5 In both cases as given in 7.4.5.5-.1 and 7.4.5.5-.2, the NO_x reducing device shall be included on the EIAPP Certificate together with the emission value obtained with the device in operation and all other records as required by the Administration. The engine's Technical File shall also contain onboard NO_x verification procedures for the device to ensure it is operating correctly.

- .6 Notwithstanding 7.4.5.5-3 and 7.4.5.5-4, a NOx reducing device may be approved by the Administration taking into account guidelines to be developed by the IMO.

7.4.5.6 Where, due to changes of component design, it is necessary to establish a new Engine Family or Engine Group but there is no available Parent Engine the engine builder may apply to the Administration to use the previously obtained Parent Engine test data modified at each specific mode of the applicable test cycle so as to allow for the resulting changes in NOx emission values. In such cases, the engine used to determine the modification emission data shall correspond in accordance with 7.4.12.12-1 to the previously used Parent Engine. Where more than one component is to be changed the combined effect resulting from those changes is to be demonstrated by a single set of test results.

7.4.5.7 For pre-certification of engines within an Engine Family or Engine Group, an EIAPP Certificate shall be issued in accordance with procedures established by the Administration to the Parent Engine(s) and to every Member Engine produced under this certification to accompany the engines throughout their life whilst installed on ships under the authority of that Administration.

7.4.5.8 Issue of certification by the Administration of the country in which the engine is built

- .1 When an engine is manufactured outside the country of the Administration of the ship on which it will be installed, the Administration of the ship may request the Administration of the country in which the engine is manufactured to survey the engine. Upon satisfaction that the applicable requirements of 7.3.2 are complied with pursuant to the *NOx Technical Code 2008*, the Administration of the country in which the engine is manufactured shall issue or authorise the issuance of the EIAPP Certificate.
- .2 A copy of the certificate(s) and a copy of the survey report shall be transmitted as soon as possible to the requesting Administration.
- .3 A certificate so issued shall contain a statement to the effect that it has been issued at the request of the Administration.

7.4.5.9 Guidance in respect of the pre-certification survey and certification of marine diesel engines, as described in 7.4.4, is given in the relevant flowchart (see 7.4.17.1) of the *NOx Technical Code 2008*. Where discrepancies exist, the text of 7.4.4 takes precedence.

7.4.6 Procedures for certification of an engine

7.4.6.1 For those engines which have not been adjusted or modified relative to the original specification of the manufacturer, the provision of a valid EIAPP Certificate should suffice to demonstrate compliance with the applicable NOx limits.

7.4.6.2 After installation on board, it shall be determined to what extent an engine has been subjected to further adjustments and/or modifications which could affect the NOx

emission. Therefore, the engine, after installation on board, but prior to issuance of the IAPP Certificate, shall be inspected for modifications and be approved using the on-board NOx verification procedures described in 7.4.7.3.

7.4.6.3 There are engines which, after pre-certification, need final adjustment or modification for performance. In such a case, the Engine Group concept could be used to ensure that the engine still complies with the applicable limit.

7.4.6.4 Every marine diesel engine installed on board a ship shall be provided with a Technical File. The Technical File shall be prepared by the applicant for engine certification and approved by the Administration, and is required to accompany an engine throughout its life on board ships. The Technical File shall contain the information as specified in 7.4.7.1.

7.4.6.5 Where a NOx reducing device is installed and needed to comply with the NOx limits, one of the options providing a ready means for verifying compliance with 7.3.2 is the Direct Measurement and Monitoring Method in accordance with 7.4.14.4. However, depending on the technical possibilities of the device used, subject to the approval of the Administration, other relevant parameters could be monitored.

7.4.6.6 Where, for the purpose of achieving NOx compliance, an additional substance is introduced, such as ammonia, urea, steam, water, fuel additives, etc., a means of monitoring the consumption of such substance shall be provided. The Technical File shall provide sufficient information to allow a ready means of demonstrating that the consumption of such additional substances is consistent with achieving compliance with the applicable NOx limit.

7.4.6.7 Where the Engine Parameter Check method in accordance with 7.4.14.2 is used to verify compliance, if any adjustments or modifications are made to an engine after its pre-certification, a full record of such adjustments or modifications shall be recorded in the engine's Record Book of Engine Parameters or in the Electronic Record Book.

7.4.6.8 If all of the engines installed on board are verified to remain within the parameters, components, and adjustable features recorded in the Technical File, the engines should be accepted as performing within the applicable NOx limit specified in 7.3.2. In this case, provided all other applicable requirements of 7.1 to 7.3 are complied with, an IAPP Certificate should then be issued to the ship.

7.4.6.9 If any adjustment or modification is made which is outside the approved limits documented in the Technical File, the IAPP Certificate may be issued only if the overall NOx emission performance is verified to be within the required limits by:

- .1 onboard Simplified Measurement in accordance with 7.4.14.3; or
- .2 reference to the test-bed testing for the relevant Engine Group approval showing that the adjustments or modifications do not exceed the applicable NOx emission limit.

At surveys after the initial engine survey, the Direct Measurement and Monitoring method in accordance with Chapter 6.4 of the *NOx Technical Code 2008*, as approved by the Administration, may alternatively be used.

7.4.6.10 The Administration may, at its own discretion, abbreviate or reduce all parts of the survey on board, in

accordance with the *NOx Technical Code 2008* to an engine which has been issued an EIAPP Certificate. However, the entire survey on board must be completed for at least one cylinder and/or one engine in an Engine Family or Engine Group, if applicable, and the abbreviation may be made only if all the other cylinders and/or engines are expected to perform in the same manner as the surveyed engine and/or cylinder. As an alternative to the examination of fitted components, the Administration may conduct that part of the survey on spare parts carried on board provided they are representative of the components fitted.

7.4.6.11 Guidance in respect of the survey and certification of marine diesel engines at initial, renewal, annual and intermediate surveys, as described in 7.4.6, is given in the relevant flowchart (see 7.4.17.1) of the *NOx Technical Code 2008*. Where discrepancies exist, the text of 7.4.6 takes precedence.

7.4.7 Technical file and on-board NOx verification procedures

7.4.7.1 To enable the Administration to perform the engine surveys described in 7.4.4, the Technical File required by 7.4.6.4 shall, at a minimum, contain the following information:

- .1 Identification of those components, settings and operating values of the engine which influence its NOx emissions including any NOx reducing device or system;
- .2 Identification of the full range of allowable adjustments or alternatives for the components of the engine;
- .3 Full record of the relevant engine's performance, including the engine's rated speed and rated power;
- .4 a system of on-board NOx verification procedures to verify compliance with the NOx emission limits during on-board verification surveys in accordance with 7.4.14;
- .5 A copy of the relevant Parent Engine test data, as given in section 2 of appendix 5 of the *NOx Technical Code 2008*;
- .6 If applicable, the designation and restrictions for an engine which is an engine within an Engine Family or Engine Group;
- .7 specifications of those spare parts / components which, when used in the engine, according to those specifications, will result in continued compliance of the engine with the NOx emission limit; and
- .8 the EIAPP Certificate, as applicable.

7.4.7.2 As a general principle, onboard NOx verification procedures shall enable a surveyor to easily determine if an engine has remained in compliance with the applicable requirements of 7.3.2. At the same time, it shall not be so burdensome as to unduly delay the ship or to require in-depth knowledge of the characteristics of a particular engine or specialist measuring devices not available on board.

7.4.7.3 The onboard NOx verification procedure shall be one of the following methods:

- .1 Engine Parameter Check method in accordance with 7.4.14.2 to verify that an engine's component, setting and operating

values have not deviated from the specifications in the engine's Technical File;

- .2 Simplified Measurement method in accordance with 7.4.14.3; or
- .3 Direct Measurement and Monitoring method in accordance with 7.4.14.4.

7.4.7.4 When considering which onboard NOx verification procedures should be included in an engine's Technical File to verify whether an engine complies with the applicable NOx emission limit during the required onboard verification surveys, other than at an engine's initial onboard survey, any of the three onboard NOx verification procedures as specified in 7.4.14.1 may be applied. However, the procedures associated with the method applied are to be approved by the Administration. If the method differs from the verification procedure method specified in the Technical File as originally approved, the procedure of the method needs to be either added as an amendment to the Technical File or appended as an alternative to the procedure given in the Technical File. Thereafter the shipowner may choose which of the methods approved in the Technical File is to be used to demonstrate compliance.

7.4.7.5 In addition to the method specified by the engine manufacturer and given in the Technical File, as approved by the Administration for the initial certification in the engine, the shipowner shall have the option of direct measurement of NOx emissions in accordance with 7.4.14.4.

Such data may take the form of spot checks logged with other engine operating data on a regular basis and over the full range of engine operation or may result from continuous monitoring and data storage. Data must be current (taken within the last 30 days) and must have been acquired using the test procedures cited in the *NOx Technical Code 2008*.

These monitoring records shall be kept on board for three months for verification purposes by a Party to the Protocol of 1997. Data shall also be corrected for ambient conditions and fuel specification, and measuring equipment must be checked for correct calibration and operation, in accordance with the approved procedures given in the Onboard Operating Manual.

Where exhaust gas after-treatment devices are fitted which influence the NOx emissions, the measuring point(s) must be located downstream of such devices.

7.4.8 Rational emission control strategy

7.4.8.1 In addition to 7.4.5, the requirements of this section shall apply.

7.4.8.2 A rational emission control strategy shall be applied to each marine diesel engine across the whole of its operating load and speed range. The means by which that is achieved shall be documented by the applicant to the Administration within a NOx certification pack. The information included in that pack shall be such as to demonstrate to the satisfaction of the Administration that a rational emission control strategy is applied during normal operation of the engine.

7.4.8.3 For an engine where one or more auxiliary control devices are applied, each of those shall be declared to the Administration within the NOx certification pack irrespective of whether those operate under steady-state or transient

conditions. An auxiliary control device which is not so declared shall be considered a defeat device and hence invalidate the NO_x certification of an engine to which such an undeclared device is applied.

7.4.8.4 For screening of the base emission control strategy, the NO_x certification pack shall include:

- .1 a list of all NO_x emission influencing setting and operating values controlled by an engine's base emission control strategy, for example fuel injection, inlet and exhaust valve operation, charge air management, exhaust bypass/wastegate or exhaust after-treatment controls;
- .2 a record of the reference values for the settings and operating values identified in 7.4.8.4.1 at each of the mode points of the applicable test cycle;
- .3 documentation that whenever the engine is operating between two mode points as identified in 7.4.8.4.2, the emission control strategy interpolates progressively between the mode points;
- .4 documentation to show that, along lines of constant power and varying speed from the line between the mode points to the limit area of the not-to-exceed zone of the engine, the base emission control strategy shall ensure that any variation in the point emission values is progressive and justified from the value at that power on the line between the mode points, unless rationalized by an auxiliary control device or explained by a physical limitation of the engine;
- .5 a declaration that the engine's base emission control strategy only reacts to changes in engine load and speed;
- .6 any other information the applicant considers relevant; and
- .7 any other information the Administration requests.

7.4.8.5 For each auxiliary control device which may operate under steady-state conditions, the NO_x certification pack shall include:

- .1 a justification of the need for that device; and
- .2 a description for that device, including:
 - .1 details of the conditions under which that device will operate and the functioning of that device;
 - .2 how each modulated parameter of the emission control system achieves the stated purpose of the base emission control strategy;
 - .3 the process used to ensure that the modulation is limited to the conditions where the stated purpose of the auxiliary control device operational strategy arises and to set the modulation to be the minimum necessary to achieve that stated purpose;

- .4 the effect of the application of that device on the engine's base emission control strategy;
 - .5 for auxiliary control devices that operate above 25% engine power, the effect on the point emission values shall be documented;
 - .6 for auxiliary control devices that operate within the declared not-to-exceed zone, an estimate of the effect on the point emission values shall be documented;
 - .7 any other information the applicant considers relevant; and
 - .8 any other information the Administration requests.
- .3 Auxiliary control devices that only operate during transient conditions need not be included in the NO_x certification pack for screening.

7.4.8.6 The technical file as required by 7.4.6.4 shall contain the following information:

- .1 identification of those auxiliary control devices declared under 7.4.8.3;
- .2 for those auxiliary control devices covered under 7.4.8.5, the operating conditions which will cause those devices to function;
- .3 the means by which the operation of those auxiliary control devices under 7.4.8.5 may be verified as part of the onboard NO_x verification procedure; and
- .4 where the provisions of 7.4.6.6 apply, the means by which it is to be verified that the required quantities of additional substance used are consistent with achieving the engine's intended base emission control strategy shall be included as part of the onboard NO_x verification procedure.

7.4.8.7 Where acceptable to the Administration, the documentation requirements of 7.4.8.4 and 7.4.8.5 may alternatively be made by reference to that in respect of marine diesel engines comparable, in terms of NO_x emissions characteristics, to the engine to be certified.

7.4.8.8 The provisions of this section only apply to a marine diesel engine which is installed in a ship as an identical replacement engine if the requirements of this section applied at the time the engine family or engine group to which that engine belongs was first certified.

Nitrogen oxides emission standards

7.4.9 Maximum allowable NO_x emission limits for marine diesel engines

7.4.9.1 The maximum allowable NO_x emission limit values are given by 7.3.2.3, 7.3.2.4, 7.3.2.5-1.1 and 7.3.2.7-4 as applicable. The total weighted NO_x emissions, as measured and calculated, rounded to one decimal place, in accordance with the procedures in of the *NO_x Technical Code 2008* shall be equal to or less than the applicable calculated value corresponding to the rated speed of the engine.

7.4.9.2 When the engine operates on test fuel oils in accordance with Chapter 5.3 of the *NOx Technical Code 2008* the total emission of nitrogen oxides (calculated as the total weighted emission of NO₂) shall be determined using the relevant test cycles and measurement methods as specified in the *NOx Technical Code 2008*.

7.4.9.3 An engine's exhaust emissions limit value, given from the formulae included in 7.3.2.3, 7.3.2.4, 7.3.2.5-.1.1 as applicable, and the actual calculated exhaust emissions value, rounded to one decimal place for the engine, shall be stated on the engine's EIAPP Certificate. If an engine is a Member Engine of an Engine Family or Engine Group, it is the relevant Parent Engine emission value that is compared to the applicable limit value for that Engine Family or Engine Group. The limit value given here shall be the limit value for the Engine Family or Engine Group based on the highest engine speed to be included in that Engine Family or Engine Group, in accordance with paragraph 7.3.2.3, 7.3.2.4, 7.3.2.5-.1.1, irrespective of the rated speed of the Parent Engine or the rated speed of the particular engine as given on the engine's EIAPP certificate.

7.4.9.4 In the case of a marine diesel engine to be certified in accordance with 7.3.2.5-.1.1 the specific emission at each individual mode point shall not exceed the applicable NOx emission limit value by more than 50% except as follows:

- .1 The 10% mode point in the D2 test cycle specified in 7.4.10.4.
- .2 The 10% mode point in the C1 test cycle specified in 7.4.10.5.
- .3 The idle mode point in the C1 test cycle specified in 7.4.10.5.

7.4.10 Test cycles and weighting factors to be applied

7.4.10.1 For every Individual Engine or Parent Engine of an Engine Family or Engine Group, one or more of the relevant test cycles specified in 7.4.10.2 to 7.4.10.5 shall be applied for verification of compliance with the applicable NOx emission limit contained in 7.3.2. Appendix IX provides guidance on the selection of the appropriate test cycle but where discrepancies exist the text of Chapter 3 of this Code takes precedence.

7.4.10.2 For a fixed pitch propeller propulsion engine or a propeller-law operated non-propulsion engine, test cycle E3 shall be applied in accordance with Table 7.4.10.2.

Table 7.4.10.3
Test cycle for Constant-speed main propulsion application (including diesel-electric drive and all controllable-pitch propeller installations)

Test cycle type E2		
Speed	Power	Weighting factor
100%	100%	0,20
100%	75%	0,50
100%	50%	0,15
100% ^{a)}	25%	0,15

Note:
a) There are exceptional cases, including large bore engines intended for E2 applications, in which, due to their oscillating masses and construction, engines cannot be run at low load at nominal speed without the risk of damaging essential components. In such cases, the engine manufacturer shall make application to the Administration that the test cycle as given in this Table may be modified for the 25% power mode with regard to the engine speed. The adjusted engine speed at 25% power, however, shall be as close as possible to the rated engine speed, as recommended by the engine manufacturer and approved by the Administration. The applicable weighting factors for the test cycle shall remain unchanged.

7.4.10.3 For a propulsion engine that does not operate with a fixed pitch propeller, including an engine fitted as part of a diesel-electric installation or an engine operated with a controllable-pitch propeller, test cycle E2 shall be applied in accordance with Table 7.4.10.3.

7.4.10.4 For a non-propulsion engine that is a constant-speed engine, test cycle D2 shall be applied in accordance with Table 7.4.10.4.

7.4.10.5 For a non-propulsion engine that operates as a variable-speed engine, not included above, test cycle C1 shall be applied in accordance with Table 7.4.10.5.

Table 7.4.10.2
Test cycle for Propeller-law-operated marine engine application

Test cycle type E3		
Speed	Power	Weighting factor
100%	100%	0,20
91%	75%	0,50
80%	50%	0,15
63%	25%	0,15

Table 7.4.10.4
Test cycle for *Constant-speed auxiliary engine application*

Test cycle type D2		
Speed	Power	Weighting factor
100%	100%	0,05
100%	75%	0,25
100%	50%	0,30
100%	25%	0,30
100%	10%	0,10

Table 7.4.10.5
Test cycle for *Variable-speed, variable-load auxiliary engine application*

Test cycle type C1		
Speed	Torque	Weighting factor
Rated	100%	0,15
	75%	0,15
	50%	0,15
	10%	0,10
Intermediate	100%	0,10
	75%	0,10
	50%	0,10
Idle	0%	0,15

7.4.10.6 The torque figures given in test cycle C1 are percentage values which represent for a given test mode the ratio of the required torque to the maximum possible torque at this given speed.

7.4.10.7 The intermediate speed for test cycle C1 shall be declared by the manufacturer, taking into account the following requirements:

- .1 For engines which are designed to operate over a speed range on a full load torque curve, the intermediate speed shall be the declared maximum torque speed if it occurs between 60% and 75% of rated speed.
- .2 If the declared maximum torque speed is less than 60% of rated speed, then the intermediate speed shall be 60% of the rated speed.
- .3 If the declared maximum torque speed is greater than 75% of the rated speed, then the intermediate speed shall be 75% of rated speed.
- .4 For engines which are not designed to operate over a speed range on the full load torque curve at steady state conditions, the intermediate speed will typically be between 60% and 70% of the maximum rated speed.

7.4.10.8 If an engine manufacturer applies for a new test cycle application on an engine already certified under a different test cycle specified in 7.4.10.2 to 7.4.10.5, then it may not be necessary for that engine to undergo the full certification process for the new application. In this case, the engine manufacturer may demonstrate compliance by recalculation, by applying the measurement results from the specific modes of the first certification test to the calculation of the total weighted emissions for the new test cycle application, using the corresponding weighting factors from the new test cycle.

7.4.11 Not-to-exceed emission values within the limit area of the not-to-exceed zone

7.4.11.1 The boundaries, in terms of power or torque and speed, of the not-to-exceed zone at or above 25% power shall be declared to the Administration by the applicant as part of the NOx certification pack. Operation outside these not-to-exceed zone boundaries, within the limit area of the not-to-exceed zone, shall only be permitted during starting, stopping, accelerations, deceleration, load pick-up or load rejection. However, operation below 25% power and at or above 63% speed for the E3, E2, and D2 test cycles and below 50% load for the C1 test cycle shall be permitted subject to it being shown in accordance with the requirements of 7.4.8 that a rational emission control strategy continues to be applied.

7.4.11.2 The technical file as required by 7.4.6.4 shall additionally contain the following information:

- 1 the power or torque and speed boundaries, as given by 7.4.11.1, within which the engine is certified to operate; and
- 2 the onboard NOx verification procedure shall include means to verify that the engine only operates within the power or torque and speed boundaries as given by 7.4.11.1.

7.4.11.3 Additional to the emission testing under 7.4.10 the Administration may, at its discretion, require that up to three point emission values be determined at load points within the not-to-exceed zone in order to verify that the not-to-exceed zone requirements are complied with. The load points to be tested shall be agreed between the applicant and the Administration as part of the review of the NOx certification pack. Point emission values are to be determined in accordance with the procedures given by 7.4.13 and appendix X. To be acceptable each of those point emission values so determined shall not exceed the respective not-to-exceed emission limit value, N_{Lz} , as determined using the procedure in appendix X. Point emission value \leq emission limit value N_{Lz} , at that point.

7.4.11.4 Alternative means by which it is to be shown that a point emission value may be determined or the not-to-exceed zone requirements are complied with may be used subject to their acceptability to the Administration.

7.4.11.5 For member engines of engine families or engine groups first certified prior to the effective date of the requirements under this section, demonstration of compliance with the requirements of this section may be on the basis solely of documentation which is to be acceptable to the Administration.

7.4.12 Approval for serially manufactured engines: Engine Family and Engine Group concepts

General

7.4.12.1 To avoid certification testing of every engine for compliance with the NO_x emission limits, one of two approval concepts may be adopted, namely the Engine Family or the Engine Group concept.

7.4.12.2 The Engine Family concept may be applied to any series produced engines which, through their design are proven to have similar NO_x emission characteristics, are used as produced, and, during installation on board, require no adjustments or modifications which could adversely affect the NO_x emissions.

7.4.12.3 The Engine Group concept may be applied to a smaller series of engines produced for similar engine application and which require minor adjustments and modifications during installation or in service on board.

7.4.12.4 Initially the engine manufacturer may, at its discretion, determine whether engines should be covered by the Engine Family or Engine Group concept. In general, the type of application shall be based on whether the engines will be modified, and to what extent, after testing on a test bed.

Documentation

7.4.12.5 All documentation for certification must be completed and suitably stamped by the duly authorised Authority as appropriate. This documentation shall also include all terms and conditions, including replacement of spare parts, to ensure that an engine is maintained in compliance with the applicable NO_x emission limit.

7.4.12.6 For an engine within an Engine Family or Engine Group, the required documentation for the Engine Parameter Check method is specified in [7.4.14.2-8.1](#).

Application of the Engine Family concept

7.4.12.7 The Engine Family concept provides the possibility of reducing the number of engines which must be submitted for approval testing, while providing safeguards that all engines within the Engine Family comply with the approval requirements. In the Engine Family concept, engines with similar emission characteristics and design are represented by a Parent Engine.

7.4.12.8 Engines that are series produced and not intended to be modified may be covered by the Engine Family concept.

7.4.12.9 The necessary details related to the application of the Engine Family concept, containing amongst other:

- .1 Guidance for the selection of an Engine Family;
- .2 Guidance for selecting the Parent Engine of an Engine Family; and
- .3 Certification of an Engine Family;

are stated in Chapter 4.3 of the *NO_x Technical Code 2008*.

Application of the Engine Group concept

7.4.12.10 Engine Group engines normally require adjustment or modification to suit the onboard operating conditions but these adjustments or modifications shall not result in NO_x emissions exceeding the applicable limits in 7.3.2.

7.4.12.11 The Engine Group concept also provides the possibility for a reduction in approval testing for modifications to engines in production or in service.

7.4.12.12 The necessary details related to the application of the Engine Family concept, containing amongst other:

- .1 Guidance for the selection of an Engine Group;
- .2 Guidance for allowable adjustment or modification within an Engine Group;
- .3 Guidance for the selection of the Parent Engine of an Engine Group; and
- .4 Certification of an Engine Group;

are stated in Chapter 4.4 of the *NO_x Technical Code 2008*.

7.4.12.13 Conformity of production arrangements relative to application of the engine family/group concept is addressed in IACS UI MPC 106.

7.4.12.14 Additional parameters for definition of the engine group, regarding engines fitted with SCR system to reduce NO_x emissions, may be used as specified in IACS UI MPC 125.

7.4.13 Procedures for NO_x emission measurements on a test bed

7.4.13.1 These procedures shall be applied to every initial approval testing of a marine engine regardless of the location of that testing (the methods described in 7.4.4.2-.1 and 7.4.4.2-.2).

7.4.13.2 Chapter 5 of the *NO_x Technical Code 2008* specifies the measurement and calculation methods for gaseous exhaust emissions from reciprocating internal-combustion engines under steady-state conditions, necessary for determining the average weighted value for the NO_x exhaust gas emission.

7.4.13.3 Many of the procedures described in the Chapter 5 of the *NO_x Technical Code 2008* are detailed accounts of laboratory methods, since determining an emissions value requires performing a complex set of individual measurements, rather than obtaining a single measured value. Thus, the results obtained depend as much on the process of performing the measurements as they depend on the engine and test method.

7.4.13.4 Chapter 5 of the *NO_x Technical Code 2008* includes the test and measurement methods, test run and test report as a procedure for a test-bed measurement. That Chapter specifies amongst other:

- .1 Test conditions;
- .2 Test fuel oils;
- .3 Measurement equipment and data to be measured;
- .4 Determination of exhaust gas flow;
- .5 Permissible deviations of instruments for engine-related parameters and other essential parameters;

- .6 Analysers for determination of the gaseous components;
- .7 Calibration of the analytical instruments;
- .8 Test run;
- .9 Test report;
- .10 Data evaluation for gaseous emissions; and
- .11 Calculation of the gaseous emissions.

7.4.13.5 The weighting factors and the number of modes used in the calculation in accordance with the calculation **7.4.13.4-.11** shall be according to the provisions of **7.4.10**.

7.4.13.6 The resulting average weighted NOx emission value for the engine as determined the calculation **7.4.13.4-.11** shall then be compared to the applicable emission limit given in 7.3.2 to determine if the engine is in compliance.

7.4.13 Procedures for demonstrating compliance with NOx emission limits on board

7.4.14.1 After installation of a pre-certificated engine on board a ship, every marine diesel engine shall have on-board verification surveys conducted as specified in 7.4.4.1-.2 to 7.4.4.1-.4), to verify that the engine continues to comply with the NOx emission limit contained in 7.3.2. Such verification of compliance shall be determined by using one of the following methods:

- .1 Engine Parameter Check method in accordance with 7.4.14.2 to verify that an engine's component, settings and operating values have not deviated from the specifications in the engine's Technical File;
- .2 Simplified Measurement method in accordance with **7.4.14.3**; or
- .3 Direct Measurement and Monitoring method in accordance with **7.4.14.4**.

7.4.14.2 Engine Parameter Check method

- .1 Engines that meet the following conditions shall be eligible for an Engine Parameter Check method:
 - .1 engines that have received a pre-certificate (EIAPP Certificate) on the test bed and those that received a certificate (EIAPP Certificate) following an initial certification survey in accordance with 7.4.5.4; and
 - .2 engines that have undergone modifications or adjustments to the designated engine components and adjustable features since they were last surveyed.
- .2 When a marine diesel engine is designed to run within the applicable NOx emission limit, it is most likely that within the marine life of the engine, the NOx emission limit may be adhered to. The applicable NOx emission limit may, however, be contravened by adjustments or modification to the engine. Therefore, an Engine Parameter Check method shall be used to verify whether the engine is still within the applicable NOx emission limit.

- .3 Engine component checks, including checks of settings and an engine's operating values, are intended to provide an easy means of deducing the emissions performance of the engine for the purpose of verification that an engine with no, or minor adjustments or modifications complies with the applicable NOx emission limit. Where the measurement of some operating values is required, the calibration of the equipment used for those measurements shall be in accordance with the requirements of appendix 4 of the *NOx Technical Code 2008*.

- .4 The purpose of such checks is to provide a ready means of determining that an engine is correctly adjusted in accordance with the manufacturer's specification and remains in a condition of adjustment consistent with the initial certification by the Administration as being in compliance with 7.3.2 as applicable.

- .5 If an electronic engine management system is employed, this shall be evaluated against the original settings to ensure that appropriate parameters are operating within *as-built* limits.

- .6 For the purpose of assessing compliance with 7.3.2, it is not always necessary to measure the NOx emissions to know that an engine, not equipped with an after-treatment device, is likely to comply with the applicable NOx emission limit. It may be sufficient to know that the present state of the engine corresponds to the specified components, calibration or parameter adjustment state at the time of initial certification. If the results of an Engine Parameter Check method indicate the likelihood that the engine complies with the applicable NOx emission limit, the engine may be re-certified without direct NOx measurement.

- .7 For an engine equipped with a NOx reducing device, it will be necessary to check the operation of the device as part of the Engine Parameter Check method.

- .8 The remaining details specifying:
 - .1 documentation; and
 - .2 procedures;

for the Engine Parameter Check method have been stated in the Chapter 6.2 of the *NOx Technical Code 2008*.

7.4.14.3

Simplified Measurement method

- .1 The simplified test and measurement procedure, as specified in the Chapter 6.3 of the *NOx Technical Code 2008*, shall be applied only for onboard confirmation tests and renewal, annual and intermediate surveys when required. Every first engine testing on a test bed shall be carried out in accordance with the procedure specified in **7.4.13**. Corrections for ambient air temperature and humidity are essential as

- ships are sailing in cold/hot and dry/humid climates, which may cause a difference in NO_x emissions.
- .2 To gain meaningful results for onboard confirmation tests and onboard renewal, annual and intermediate surveys, as an absolute minimum, the gaseous emission concentrations of NO_x and CO₂ shall be measured in accordance with the appropriate test cycle. The weighting factors and the number of modes used in the calculation shall be in accordance with 7.4.10.
 - .3 The engine torque and engine speed shall be measured but, to simplify the procedure, the permissible deviations of instruments for measurement of engine-related parameters for onboard verification purposes is different than from those permissible deviations allowed under the test-bed testing method. If it is difficult to measure the torque directly, the brake power may be estimated by any other means recommended by the applicant for engine certification and approved by the Administration.
 - .4 The remaining necessary details specifying amongst other:
 - .1 engine parameters to be measured and recorded;
 - .2 brake power;
 - .3 test fuel oils;
 - .4 sampling for gaseous emissions;
 - .5 measurement equipment and data to be measured;
 - .6 permissible deviation of instruments for engine related parameters and other essential parameters;
 - .7 determination of the gaseous components;
 - .8 test cycles;
 - .9 calculation of gaseous emissions; and
 - .10 allowances
 - .4 The remaining necessary details specifying amongst other:
 - .1 emission species measurement;
 - .2 engine performance measurements;
 - .3 ambient condition measurements;
 - .4 engine performance and ambient condition monitoring equipment;
 - .5 test cycles;
 - .6 test condition parameter;
 - .7 analyser in-service performance;
 - .8 data for emission calculation;
 - .9 exhaust gas flow rate;
 - .10 fuel oil composition;
 - .11 dry/wet correction;
 - .12 NO_x correction for humidity and temperature;
 - .13 calculation of emission flow rates and specific emissions;
 - .14 limit value and allowances; and
 - .15 data for demonstrating compliance;

for the Direct Measurement and Monitoring method have been stated in the Chapter 6.4 of the *NO_x Technical Code 2008*.
 - .5 Form of approval
The Direct Measurement and Monitoring method shall be documented in an Onboard Monitoring Manual. The Onboard Monitoring Manual shall be submitted to the Administration for approval. The approval reference of that Onboard Monitoring Manual shall be entered under section 3 of the Supplement to the EIAPP Certificate. The Administration may issue a new EIAPP Certificate, with the details in section 3 of the Supplement duly amended, if the method is approved after the issue of the first EIAPP Certificate, i.e. following the pre-certification survey
 - .6 Survey of equipment and method
The survey of the Direct Measurement and Monitoring method shall take into account, but is not limited to:
 - .1 the data obtained and developed from the required measurements; and
 - .2 the means by which that data has been obtained, taking into account the information given in the Onboard Monitoring Manual.

for the Simplified Measurement method have been stated in the Chapter 6.3 of the *NO_x Technical Code 2008*.

7.4.14.4 Direct Measurement and Monitoring method

- 1 The Direct Measurement and Monitoring procedure may be applied for onboard verification at renewal, annual and intermediate surveys.
- .2 Due attention is to be given to the safety implications related to the handling and proximity of exhaust gases, the measurement equipment and the storage and use of cylindered pure and calibration gases. Sampling positions and access staging shall be such that this monitoring may be performed safely and will not interfere with the engine.
- .3 Onboard NO_x monitoring includes, as an absolute minimum, the measurement of gaseous emission concentrations of NO_x (as NO+NO₂).

7.4.15 Certification of an Existing Engine

7.4.15.1 Certification of an existing engine under regulation 7.3.2.7

7.4.15.1.1 Where an Existing Engine is to comply with 7.3.2.7, then the entity responsible for obtaining emissions certification shall apply to the approving Administration for certification.

7.4.15.1.2 Where an application for Approved Method approval includes gaseous emission measurements and calculations, those are to be in accordance with 7.4.13.

7.4.15.1.3 Emission and performance data obtained from one engine may be shown to apply to a range of engines.

7.4.15.1.4 The Approved Method for achieving compliance with 7.3.2.7 shall include a copy of the Approved Method File which is required to accompany the engine throughout its life on board ship.

7.4.15.1.5 A description of the engine's onboard verification procedure shall be included in the Approved Method File.

7.4.15.1.6 After installation of the Approved Method, a survey shall be conducted in accordance with the Approved Method File. If this survey confirms compliance, the Administration shall amend the ship's IAPP Certificate accordingly.

7.4.15.1.7 Guidelines on the approved method process are set out in IMO Res. MEPC.243(66).

7.4.15.2 Certification of an engine subject to substantial modification or being certified to a Tier to which the engine was not certified at the time of its installation

7.4.15.2.1 Further to 7.4.4.1.4, 7.4.4.2.2 and 7.4.12.12, the procedures as given in this section shall be followed where an installed marine diesel engine:

- 1 has been subject to substantial modification; or
- 2 is to be certified to a Tier to which it was not certified at the time of its installation.

7.4.15.2.2 The requirements of this Code apply other than as specifically provided for by this section.

7.4.15.2.3 The procedures given by this section may be accepted for an Individual Engine or for an Engine Group represented by the Parent Engine. It shall not be accepted for Engine Family certification.

7.4.15.2.4 Where, as a result of the substantial modification, the rated power and/or the rated speed of the engine is altered from the original condition the engine nameplate shall be replaced accordingly.

7.4.15.2.5 In setting the load points of the test cycle to be followed the provisions of 6.4.6.7 of the *NOx Technical Code 2008* shall apply. In the case of the 100% load point this shall, subject to the Engine Emission test plan, be allowed to be no lower than 85% of rated power. If that value cannot be achieved, then the test shall be deferred to such time that at least that power level can be achieved. The test cycle 100% power weighting factor under 7.4.10 shall be applied irrespective of actual power developed at that load point.

7.4.15.2.6 At each load point of a test cycle, the provisions of 6.4.6.8 of the *NOx Technical Code 2008* shall apply rather than those of 5.9.6.2 of the *NOx Technical Code 2008*.

7.4.15.2.7 In the case of the E3 test cycle, if the actual propeller curve differs from the E3 curve, the load point used shall be set using the measured engine power.

7.4.15.2.8 Engine performance and ambient condition monitoring equipment requirements shall be in accordance with the requirements of 6.4.5.1 of the *NOx Technical Code 2008*.

7.4.15.2.9 In terms of the NOx correction for humidity and temperature, the provisions of 6.4.13 of the *NOx Technical Code 2008* shall apply.

7.4.15.2.10 The Engine Emission test plan as prepared by the applicant shall be agreed with the Administration before scheduling that test.

7.4.15.2.11 The certification of a Member Engine of the Engine Group as established following the provisions of this section shall follow the procedures specified in 7.4.5.2.

7.4.15.2.12 Guidance in respect of the certification of a marine diesel engine subject to substantial modification or being certified to a Tier to which the engine was not certified at the time of its installation is given by figure 4 of appendix II (see 7.4.17.1) of this Code. Where discrepancies exist, the text of the *NOx Technical Code 2008* takes precedence.

7.4.16 Multiple engine operational profiles

7.4.16.1 Acceptance of multiple engine operational profiles

7.4.16.1.1 The switching between engine operational profiles under onboard conditions is permitted, subject to the provisions of this paragraph, in the following cases:

- 1 for a marine diesel engine certified to be in-service switchable between emission tiers;
- 2 for a marine diesel engine certified to more than one test cycle application in accordance with 7.4.10 where the engine operational profile is in-service switchable based on the duty the engine is performing; or
- 3 for a marine diesel engine certified to the same emission standard, the same rated power, same rated speed and the same test cycle which is in-service switchable between multiple engine operational profiles.

7.4.16.1.2 A marine diesel engine certified in accordance with 7.4.16.1.1.1 and/or 7.4.16.1.1.2 may additionally be switchable, at a particular tier and or duty, between multiple engine operational profiles in which cases the provisions of 7.4.16.1.1.3 also apply.

7.4.16.1.3 Each engine operating profile shall be identified in the technical file as required by 7.4.6.4 together with the conditions, if applicable, under which each engine operating profile is to be used.

7.4.16.2 Certification of multiple engine operational profiles

7.4.16.2.1 For a marine diesel engine to which 7.4.16.1.1.1 applies, the parent engine test report for each tier shall be included in the technical file as required by 7.4.7.1.5. The parent engine specific emission value for each tier shall be entered under 1.9.6 of the Supplement to the EIAPP Certificate.

7.4.16.2.2 For a marine diesel engine to which 7.4.16.1.1.2 applies, the parent engine test report for each test cycle shall be included in the technical file as required by 7.4.7.1.5. The test cycles for which the engine is certified shall be shown on the EIAPP Certificate. The parent engine specific emission value for each test cycle shall be entered and identified under 1.9.6 of the Supplement to the EIAPP Certificate.

7.4.16.2.3 For a marine diesel engine to which 7.4.16.1.1.3 applies:

- .1 the engine test report for each engine with the parent engine features and characteristics identified in 7.4.12.9.2 or 7.4.12.12.3, for each engine operational profile, shall be determined in accordance with the provisions of chapter 5 of this Code. Where there is a mode point condition which is the same among the different engine operational profiles, that is not required to be repeated for each test cycle. The required testing may not necessarily be undertaken on the same physical engine;
- .2 the specific emission value determined in accordance with 5.12.6.1 of the NO_x Technical Code 2008 for each engine operational profile shall not exceed the applicable limit value as given by 7.3.2;
- .3 the multiple engine operational profile parent engine specific emission value shall be determined in accordance with 5.12.6.1 of the NO_x Technical Code 2008 from the highest NO_x emission rate, q_{mgasi} as per 5.12.5.2 of the NO_x Technical Code 2008, at each mode point across all the engine operational profiles for which the engine is to be certified;
- .4 the parent engine test report for each engine operational profile for which the engine is to be certified shall be included in the technical file as required by 7.4.7.1.5 together with the determination of the multiple engine operational profile parent engine specific emission value;
- .5 the multiple engine operational profile parent engine specific emission value shall be entered under 1.9.6 of the Supplement to the EIAPP Certificate; and
- .6 Section 2.2.1 of the Supplement to the IAPP Certificate shall be completed to identify which engines installed on a ship are approved to operate with multiple engine operational profiles.

7.4.16.3 Use of multiple engine operational profiles

7.4.16.3.1 An engine operational profile shall only be used in accordance with the associated conditions as given in the technical file.

7.4.16.3.2 The identification reference of the engine operational profile in use shall be recorded as part of the onboard NO_x verification procedure together with data that demonstrates that the conditions attached to the use of that engine operational profile were being complied with.

7.4.16.3.3 On change from one engine operational profile to another, the date and time of the completion of that change shall be recorded as part of the onboard NO_x verification procedure for that engine.

7.4.17 Additional reference information

7.4.17.1 Flowcharts for survey and certification of marine diesel engines (referred to 7.4.5.9, 7.4.6.11 and 7.4.15.2.12) are available in the Appendix 2 of the *NO_x Technical Code 2008*.

7.4.17.2 Specifications for analysers to be used in the determination of gaseous components of marine diesel engine emissions (referred to 7.4.13) are stated in the Appendix 3 of the *NO_x Technical Code 2008*.

7.4.17.3 Calibration of the analytical and measurement instruments (referred to 7.4.12, 7.4.13 and 7.4.14) is stated in the Appendix 4 of the *NO_x Technical Code 2008*.

7.4.17.4 Parent Engine test report, test data and determination of the highest composite specific emission value (referred to 7.4.7.1-5, 7.4.13.4-9 and 7.4.16.2.3) are stated in the Appendix 5 of the *NO_x Technical Code 2008*.

7.4.17.5 Calculation of exhaust gas mass flow, i.e. carbon-balance method (referred to 7.4.13) is stated in the Appendix 6 of the *NO_x Technical Code 2008*.

7.4.17.6 Checklist for an engine parameter check method (referred to 6.2.2.5 of the *NO_x Technical Code 2008*) is stated in the Appendix 7 of the *NO_x Technical Code 2008*.

7.4.17.7 Implementation of the Direct Measurement and Monitoring method (referred to 7.4.14.4) is stated in the Appendix 8 of the *NO_x Technical Code 2008*.

7.4.17.8 Flowchart for engine certification test cycle determination (referred to 7.4.10) is available in the Appendix 9 of the *NO_x Technical Code 2008*.

7.4.17.9 Calculation of not-to-exceed emission limit value within not-to-exceed zone (referred to 7.4.11, and chapters 3 and 5 of the *NO_x Technical Code 2008*) is stated in the Appendix 10 of the *NO_x Technical Code 2008*.

8 CONTROL OF HARMFUL ANTI-FOULING SYSTEMS ON SHIPS

8.1 GENERAL REQUIREMENTS

8.1.1 General

Requirements of this Section are based on the AFS Convention, as amended by MEPC.331(76), and EU Regulation (EC) No. 782/2003, as may be amended.

8.1.2 Application

8.1.2.1 Requirements of this Section of the Rules apply to the ships as defined in 8.1.3.2.

8.1.2.2 With regard to:

- .1 ships flying the flag of an EU Member State,
- .2 ships not flying the flag of an EU Member State but operating under the authority of an EU Member State, and
- .3 ships that enter a port or offshore terminal of an EU Member State but do not fall within .1 or .2 above,

provisions of EU Regulation (EC) No. 782/2003, as may be amended, should apply.

8.1.3 Definitions

For the purpose of this Section of the Rules, the following definitions apply.

8.1.3.1 **Anti-fouling system** – means a coating, paint, surface, or device that is used on a ship to control or prevent attachment of unwanted organisms.

8.1.3.2 **Ship** – means a vessel of any type whatsoever operating in the marine environment and includes hydrofoil boats, air-cushion vehicles, submersibles, floating craft, fixed or floating platforms, floating storage units (FSUs) and floating production storage and off-loading units (FPSOs).

8.1.3.3 **AFS Convention** – means the International Convention on the Control of Harmful Anti-fouling Systems on Ships, 2001, as amended by IMO Res. MEPC.331(76).

8.1.3.4 **EU Regulation (EC) No. 782/2003** – means the Regulation of the European Parliament and of the Council of 14th April 2003 on the prohibition of organotin compounds on ships.

8.1.3.5 **Length** – means the length as defined in the International Convention on Load Lines, 1966, as modified by the Protocol of 1988 relating thereto.

8.1.3.6 **Gross tonnage** - means the gross tonnage calculated in accordance with the tonnage measurement regulations contained in annex 1 to the International Convention on Tonnage Measurement of Ships, 1969, or any successor Convention.

8.1.3.7 **International voyage** - means a voyage by a ship entitled to fly the flag of one State to or from a port, shipyard, or offshore terminal under the jurisdiction of another State.

8.1.3.8 **Administration** - means the Government of the State under whose authority the ship is operating. With respect to a ship entitled to fly a flag of a State, the Administration is the Government of that State. With respect to fixed or floating platforms engaged in exploration and exploitation of the seabed and subsoil thereof adjacent to the coast over which the coastal State exercises sovereign rights for the purposes of exploration and exploitation of their natural resources, the Administration is the Government of the coastal State concerned.

8.2 HARMFUL ANTI-FOULING SYSTEMS ON SHIPS AND CONTROL MEASURES

8.2.1 Harmful anti-fouling systems

8.2.1.1 Organotin compounds which act as biocides in anti-fouling systems are considered harmful.

8.2.1.2 Cybutryne (CAS No. 28159-98-0) contained in anti-fouling systems is considered harmful.

8.2.2 Control measures

8.2.2.1 Anti-fouling systems as stated in 8.2.1 shall not be applied or re-applied on ships.

8.2.2.2 Ship:

- either shall not bear the anti-fouling system as stated in 8.2.1,
- or shall bear a coating that forms a barrier to such system leaching from the underlying harmful anti-fouling system.

8.2.3 Application

8.2.3.1 Requirements prohibiting use of organotin compounds which act as biocides in anti-fouling systems, as stated in 8.2.1.1, apply to all ships.

8.2.3.2 Requirements prohibiting the use of anti-fouling systems containing cybutryne, as stated in 8.2.1.2, apply to all ships as of 1 January 2023.

8.2.3.3 Control measures stated in 8.2.2 for anti-fouling systems containing organotin compounds do not apply to fixed and floating platforms, FSUs, and FPSOs that have been constructed prior to 1 January 2003 and that have not yet been in dry-dock since that date.

8.2.3.4 Control measures stated in 8.3.1.5, 8.3.1.9.5, and 8.3.1.9.6 respectively, apply to all ships bearing an anti-fouling system that contains cybutryne in the external coating layer of their hulls or external parts or surfaces on 1 January 2023, except:

- .1 Fixed and floating platforms, FSUs, and FPSOs that have been constructed prior to 1 January 2023 and that have not been in dry-dock on or after 1 January 2023;

- .2 Ships not engaged in international voyages; and
- .3 Ships of less than 400 GT engaged in international voyages, if accepted by the coastal State(s).

8.3 SURVEY AND CERTIFICATION OF ANTI-FOULING SYSTEMS ON SHIPS

8.3.1 Surveys

General requirements for survey

8.3.1.1 Ships of 400 GT and above, engaged on international voyages, excluding fixed or floating platforms, floating storage units (FSU), and floating production storage and off-loading units (FPSO), as specified in regulation 1(1) of annex 4 to the AFS Convention, shall be subject to the surveys, and are required to carry on board a valid International Anti-fouling System Certificate along with a Record of Anti-fouling Systems verifying compliance with the AFS Convention.

With regard to surveys and certification, provisions of IMO Res. MEPC.358(78) - *2022 Guidelines for Survey and Certification of Anti-Fouling Systems on Ships* should be followed, with specific requirements of the Administration to be taken into account, if any.

8.3.1.2 An initial survey covering at least the scope as in paragraph 1 of appendix II of the Guidelines contained in IMO Res. MEPC.358(78) should be held before the ship is put into service * and before the International Anti-fouling System Certificate required under regulation 2 or 3 of annex 4 to the AFS Convention is issued for the first time.

* *NOTE: Applicable either to newbuilding, or to an existing ship before the International Anti-fouling System Certificate is issued for the first time.*

8.3.1.3 A survey shall be carried out whenever the anti-fouling system is changed or replaced. Such surveys should cover the scope as in paragraph 2 of Appendix II to IMO Res. MEPC.358(78).

8.3.1.4 A major conversion affecting the anti-fouling system of a ship may be considered as a newbuilding as determined by the Administration.

Repairs generally do not require a survey. However, repairs affecting approximately twenty-five (25) percent or more of the anti-fouling system, should be considered as a change or replacement of the anti-fouling system.

A non-compliant anti-fouling system controlled under Annex 1 of the AFS Convention, that undergoes repair must be repaired, or replaced with a compliant anti-fouling system.

8.3.1.5 Ships bearing an anti-fouling system that contains cybutryne in the external coating layer of their hulls or external parts or surfaces on 1 January 2023 shall at the next scheduled renewal of the anti-fouling system after 1 January 2023, but no later than 60 months following the last application to the ship of an anti-fouling system containing cybutryne, either:

- .1 Remove the anti-fouling system; or

- .2 Apply a coating that forms a barrier to this substance leaching from the underlying non-compliant anti-fouling system.

8.3.1.6 Ships under construction, to be delivered after 1 January 2023, should comply with the requirements stated in 8.2.2 at the initial survey.

Request for survey

8.3.1.7 Prior to any survey, a request for survey should be submitted by the Company to the Administration, or to the Register, along with the ship's data required in the International Anti-fouling System Certificate.

A request for survey should be supplemented by a declaration and supporting information from the anti-fouling system manufacturer, confirming that the anti-fouling system applied, or intended to be applied to the ship is in compliance with the requirements of the Convention (with an identification of the version of the Convention referred to). Such declaration should provide the following information contained in the Record of Anti-fouling System:

- type of anti-fouling system,
- name of anti-fouling system manufacturer,
- name and colour of anti-fouling system,
- active ingredient(s) and their CAS number(s).

Conducting a survey

8.3.1.8 **Initial survey** (Reg. 1(1)(a) of the Annex 4 to the AFS Convention)

- .1 The initial survey should verify that all applicable requirements of the AFS Convention are complied with.
- .2 As part of the survey, it should be verified that the anti-fouling system specified by the documentation submitted with the request for survey complies with the AFS Convention. The survey should include verification that the anti-fouling system applied is identical to the system specified in the request for survey.
- .3 Taking into account experience gained and the prevailing circumstances, the initial survey should include the tasks as listed in paragraph 1 of Appendix II of IMO Res. MEPC.358(78).
- .4 The verification tasks set out in 8.3.1.8.2 should be conducted at any time, either before, during, or after the anti-fouling system has been applied to the ship, as deemed necessary to verify compliance. No checks or tests must affect the integrity, structure or operation of the anti-fouling system.

8.3.1.9 **Surveys when the anti-fouling systems are changed or replaced** (Reg. 1(1)(b) of Annex 4 to the AFS Convention)

- .1 If the existing anti-fouling system is confirmed by an International Anti-fouling System Certificate not to be controlled under Annex 1 to the AFS Convention, the

- provisions described in 8.3.1.8 and 8.3.1.9 apply.
- .2 If the existing anti-fouling system is declared not to be controlled under Annex 1 of the AFS Convention, without being documented by an International Anti-fouling System Certificate, a verification should be carried out to confirm that the anti-fouling system complies with the requirements of the AFS Convention. This verification may be based on sampling and/or testing and/or reliable documentation, as deemed necessary based on experience gained and the existing circumstances.
Documentation for verification could, for example, be MSDS, or similar, a declaration of compliance from the anti-fouling system manufacturer, invoices from the shipyard and/or the anti-fouling system manufacturer. To verify the new anti-fouling system, the provisions described in 8.3.1.8 apply.
 - .3 If the existing anti-fouling system has been removed, the removal should be verified in addition to the provisions described in 8.3.1.8.
 - .4 If a sealer coat has been applied, a verification should be carried out to confirm that the name, type and colour of the sealer coat applied to the ship match those specified in the request for survey, and that the existing anti-fouling system has been covered with that sealer coat. Additionally the provisions described in 8.3.1.8 apply.
 - .5 An existing anti-fouling system controlled under Annex 1 of the AFS Convention, containing organotin:
 - .1 applied on/after 1 January 2003 or a later date if specified by the Administration, should be removed in accordance with paragraph 8.3.1.9.3,
 - .2 applied before 1 January 2003 or a later date if specified by the Administration, must have been removed or covered by a sealer coat in accordance with paragraph 8.3.1.9.4, not later than 60 months after its application and latest on 1 January 2008.
 - .6 An existing anti-fouling system controlled under Annex 1 of the AFS Convention, containing cybutryne in the external coating layer:
 - .1 applied before 1 January 2023, should be removed or covered by a sealer coat in accordance with paragraph 8.3.1.9.4.
 - .7 The survey should include the tasks as listed in paragraph 2 of the Appendix II to the Guidelines in IMO Res. MEPC.358(78).

8.3.1.10 Surveys of existing ships requesting only an International Anti-fouling System Certificate

- .1 If the existing anti-fouling system is declared not to be controlled under Annex 1 to the AFS Convention, a verification should be carried out to confirm that the anti-fouling system complies with the requirements of the AFS Convention. This verification may be based on sampling and/or testing and/or reliable documentation, as deemed necessary based on experience gained and the existing circumstances. Such documentation could be MSDS or similar, a declaration of compliance from the anti-fouling system manufacturer, invoices from the shipyard and/or the anti-fouling system manufacturer. If this information raises no reasonable doubt that the system applied is compliant with annex 1 of the AFS Convention, the International Anti-fouling System Certificate may be issued on this basis.

8.3.1.11 IMO Res. MEPC.356(78) - 2022 Guidelines for brief sampling of anti-fouling systems on ships provide procedures for sampling to support the effectiveness of survey and inspection to ensure that a ship's anti-fouling system complies with the AFS Convention and should be observed. These Guidelines apply to surveys and inspections of ships subject to the AFS Convention.

NOTE: IMO Res. MEPC.379(80) – 2023 Guidelines for the development of the inventory of hazardous materials, as amended by IMO Res. MEPC.405(83) - Amendments to the 2023 Guidelines for the development of the inventory of hazardous materials are including requirements for cybutryne in the external coating layer of their hulls or external parts of surfaces above 1,000 mg/kg or 200 mg/kg, with these threshold values based on appendix I of the 2022 Guidelines for survey and certification of anti-fouling systems on ships (IMO Res. MEPC.358(78)).

Ships with an IHM Part I and bearing an anti-fouling system that contains cybutryne in the external coating layer of their hulls or external parts or surfaces above 1,000 mg/kg or 200 mg/kg determined by sampling, should update the IHM Part I accordingly to include the presence of cybutryne at the earliest, if applicable, according to specific requirements of the Administration.

8.3.2 Certificates

8.3.2.1 Issuing or endorsing the International Anti-fouling System Certificate.

The International Anti-fouling System Certificate along with the Record of Anti-fouling Systems should be:

- .1 issued upon satisfactory completion of the initial survey;
- .2 issued upon acceptance of another Party's International Anti-fouling System Certificate; or
- .3 endorsed upon satisfactory completion of a survey for change or replacement of an anti-fouling system.

8.3.2.2 A ship of 24 m or more in length, but less than 400 GT excluding fixed or floating platforms, floating storage units (FSO), and floating production storage and off-loading

units (FPSO) shall carry a Declaration on Anti-fouling System, signed by the owner or authorised representative.

Declaration on Anti-fouling System shall be accompanied by appropriate documentation enable to confirm that anti-fouling system applied is not the one stated in 8.2.

8.3.2.3 The International Anti-fouling System Certificate shall cease to be valid if the anti-fouling system is changed or replaced or is not endorsed in accordance with the AFS Convention.

8.3.2.4 The International Anti-fouling System Certificate in the amended new model form which includes cybutryne-free compliance should be issued according to the provisions of IMO Res. MEPC.331(76).

9 ENERGY EFFICIENCY FOR SHIPS

9.1 GENERAL

9.1.1 Application

The provisions of this Section shall apply to all ships (as defined in item 1.1.2.4 and in MARPOL Annex VI, Regulations 2.2.5, 2.2.7, 2.2.9, 2.2.11, 2.2.14 to 2.2.16, 2.2.20, 2.2.22, and 2.2.26 to 2.2.29) of 400 gross tonnage and above engaged on international voyages, except where expressly provided otherwise in item 9.2.1.

The provisions of this Section in 9.2.2 and 9.2.3 shall apply to new ships engaged on voyages within area of navigation 5 to 8, of 400 gross tonnage and above, listed in table 9.2.3.1.

The provisions of this Section in 9.2.5 and 9.2.6 shall apply to all ships engaged on voyages within area of navigation 5 to 8, of 400 gross tonnage and above, listed in table 9.2.3.1.

9.1.2 Definitions

9.1.2.1 Existing ship – means a ship which is not a new ship.

9.1.2.2 New ship – means a ship:

- .1 for which the building contract is placed on or after 1st January 2013; or
- .2 in the absence of a building contract, the keel of which is laid or which is at a similar stage of construction on or after 1st July 2013; or
- .3 the delivery of which is on or after 1st July 2015.

9.1.2.3 Major conversion – means a conversion of a ship:

- .1 which substantially alters the dimensions, carrying capacity or engine power of the ship; or
- .2 which changes the type of the ship; or
- .3 the intent of which in the opinion of the Register is substantially to prolong the life of the ship; or
- .4 which otherwise so alters the ship that, if it were a new ship, it would become subject to relevant provisions of the present Rules not applicable to it as an existing ship; or
- .5 which substantially alters the energy efficiency of the ship and includes any modifications that could cause the ship to exceed the applicable required EEDI as set out in item 9.2.3, or the applicable required EEXI as set out in item 9.2.6.

9.1.2.4 Energy efficiency design index (EEDI) – measure of ships energy efficiency [$g\ CO_2/t \cdot nm$].

9.1.2.5 Attained EEDI – means the EEDI value achieved by an individual ship in accordance with item 9.2.2.

9.1.2.6 Required EEDI – means the maximum value of attained EEDI that is allowed by item 9.2.3 for the specific ship type and size.

9.1.2.7 Conventional propulsion – means a method of propulsion where a main reciprocating internal combustion engine is the prime mover and coupled to a propulsion shaft either directly or through a gear box.

9.1.2.8 Non-conventional propulsion – means a method of propulsion other than conventional propulsion, including diesel-electric propulsion, turbine propulsion and hybrid propulsion systems.

9.1.2.9 Cargo ship having ice-breaking capability – means a cargo ship which is designed to break level ice independently with a speed of at least 2 knots when the level ice thickness is 1,0 m or more having ice bending strength of at least 500 kPa.

9.1.2.10 Ship delivered on or after 1st September 2019 – means a ship:

- .1 for which the building contract is placed on or after 1st September 2015; or
- .2 in the absence of a building contract, the keel of which is laid or which is at a similar stage of construction on or after 1st March 2016; or
- .3 the delivery of which is on or after 1st September 2019.

9.1.2.11 Calendar year – means the period from 1st January until 31st December inclusive.

9.1.2.12 Company – means the owner of the ship or any other organization or person such as the manager, or the bareboat charterer, who has assumed the responsibility for operation of the ship from the owner and who on assuming such responsibility has agreed to take over all the duties and responsibilities imposed by the ISM Code, as amended.

9.1.2.13 Distance travelled – means distance travelled over ground.

9.1.2.14 Attained annual operational CII – means the operational carbon intensity indicator value achieved by an individual ship in accordance with items 9.2.4 and 9.4.

9.1.2.15 Attained EEXI – means the EEXI value achieved by an individual ship in accordance with item 9.2.5.

9.1.2.16 Required annual operational CII – means the target value of attained annual operational CII in accordance with items 9.2.4 and 9.4 for the specific ship type and size.

9.1.2.17 Required EEXI – means the maximum value of attained EEXI that is allowed by item 9.2.6 for the specific ship type and size.

9.1.3 Scope of supervision

9.1.3.1 Survey and certification process of the Energy efficiency design index (EEDI) is described in IMO Res. MEPC.365(79) and MEPC.374(80) as amended by MEPC.403(83), and in IACS PR No.38.

9.1.3.2 EEDI Technical file shall be submitted to Register for verification.

following:

- The EEDI Technical file shall include the following:
- .1 deadweight (DWT) or gross tonnage (GT), the maximum continuous rating (MCR) of the main and auxiliary engines, the ship speed (v_{ref}), type of fuel, the specific fuel consumption (SFC) of the main and auxiliary engines, and the electric power table, as necessary;
 - .2 power curves (kW – knot) estimated at design stage in fully loaded condition (maximum summer load draught or draught corresponding to 70% of the ship's deadweight for container ships) and under the sea trial condition;
 - .3 principal particulars, information about ship type, classification notations and the overview of propulsion system and electricity supply system onboard;
 - .4 estimation process and methodology of the power curves at design stage;
 - .5 description of energy saving equipment;
 - .6 calculated value of the attained EEDI including the calculation summary;
 - .7 calculated values of the attained EEDI_{weather} and fw value, if those values are calculated.

9.1.3.3 The *Register* may request the submitter for additional information, as necessary, to examine the calculation process of the attained EEDI.

Additional information may include the following:

- .1 description of a tank test facility;
- .2 lines of a model ship and an actual ship;
- .3 lightweight of the ship and displacement table for the verification of the deadweight;
- .4 detailed report on the method and results of the tank test;
- .5 detailed calculation process of the ship speed;
- .6 reasons for exempting a tank test, if applicable.

9.1.3.4 *Register* shall issue the report on the preliminary verification of EEDI after verification of the attained EEDI at the design stage.

9.1.3.5 Prior to the sea trial, test procedure for the speed trial is to be submitted to the *Register*. The final displacement table and the measured lightweight, or a copy of the survey report of deadweight, and a copy of NOx Technical file are to be available to the *Register*.

9.1.3.6 The *Register* shall attend the sea trial and confirm:

- .1 propulsion and power supply system and other relevant items described in the EEDI Technical file;
- .2 draught and trim;
- .3 sea conditions;
- .4 ship speed;
- .5 shaft power and RPM of the main engine.

9.1.3.7 The EEDI Technical file shall be revised, as necessary, by taking into account results of sea trial. Such revision shall include the adjusted power curve based on the results of speed trial, the finally determined deadweight/gross tonnage, SFC described in the approved NOx Technical file, and the recalculated attained EEDI based on these modifications.

9.1.3.8 The revised EEDI Technical file shall be submitted to *Register* for the final verification and confirmation of the attained EEDI.

9.1.3.9 In case where a major conversion is made to a ship, the revised EEDI Technical file shall be submitted to *Register* for verification.

9.1.3.10 The revised EEDI Technical file in case of a major conversion shall include the following:

- .1 details of the conversion;
- .2 EEDI parameters changed after the conversion with relevant technical justifications for each parameter;
- .3 reasons for other changes made in the EEDI Technical file, if any;
- .4 calculated value of the attained EEDI with the calculation summary.

9.1.3.11 For verification of the attained EEDI after a conversion, speed trials of the ship are required, as necessary.

9.1.3.12 Survey and certification process of the Energy efficiency existing ship index (EEXI) is described in IMO Res. MEPC.351(78).

9.1.3.13 EEXI Technical file shall be submitted to *Register* for verification.

The EEXI Technical file shall include the following:

- .1 deadweight (DWT) or gross tonnage (GT), the rated installed power (MCR) of the main and auxiliary engines, the limited installed power (MCR_{lim}) if installed, the ship speed (v_{ref}), the approximate ship speed ($v_{ref,app}$), where applicable for pre-EEDI ships, type of fuel, the specific fuel consumption (SFC) of the main and auxiliary engines, and the electric power table, as necessary for certain ship types;
- .2 an approved speed-power curve (kW – knot) under the EEDI condition, where applicable, an estimated speed-power curve under the EEDI condition, or under a different load draught to be calibrated to the EEDI condition, obtained from tank test and/or numerical calculations, if available;
- .3 principal particulars, information about ship type, classification notations and the overview of propulsion system and electricity supply system onboard;
- .4 estimation process and methodology of the power curves, as necessary, including documentation on consistency with the defined quality standards (e.g. ITTC) and the verification of the numerical set-up with parent hull or the reference set of comparable ships in case of using numerical calculations;

- .5 a sea trial report including sea trial results, which may have been calibrated by the tank test, if available;
- .6 calculation process of $v_{ref,app}$ for pre-EEDI ships in cases where the speed-power curve is not available;
- .7 documented record of annual average figure of the auxiliary engine load at sea, if applicable;
- .8 calculation process of $P_{AE,app}$, as specified in paragraph 2.2.2.3 of the guidelines in 9.2.5.1, if applicable;
- .9 description of energy saving equipment, if available;
- .10 calculated value of the attained EEXI including the calculation summary;
- .11 for LNG carriers:
- .1 type and outline of propulsion system (such as direct drive diesel, diesel electric, steam turbine);
 - .2 LNG cargo tank capacity in m^3 and BOR as defined in paragraph 2.2.5.6.3 of the guidelines in item 9.2.2.1;
 - .3 shaft power of the propeller shaft after transmission gear at 100% of the rated output of motor (MPP_{Motor}) and $\eta_{(i)}$ for diesel electric;
 - .4 shaft power of the propeller shaft after transmission gear at the de-rated output of motor ($MPP_{Motor,lim}$) in cases where the overridable shaft /engine power limitation is installed;
 - .5 maximum continuous rated power ($MCR_{SteamTurbine}$) for steam turbine;
 - .6 limited maximum continuous rated power ($MCR_{SteamTurbine,lim}$) for steam turbine in cases where the overridable shaft /engine power limitation is installed; and
 - .7 $SFC_{SteamTurbine}$ for steam turbine, as specified in paragraph 2.2.7.2 of the guidelines in item 9.2.2.1. If the calculation is not available from the manufacturer, $SFC_{SteamTurbine}$ may be calculated by the submitter.
- .12 The SFC shall be corrected to the value corresponding to the ISO standard reference conditions using the standard lower calorific value of the fuel oil, referring to ISO 15550:2002 and ISO 3046-1:2002. For the confirmation of the SFC , a copy of the approved NO_x Technical File and documented summary of the correction calculations shall be submitted to the *Register*.
- .13 For ships equipped with dual-fuel engine(s) using LNG and fuel oil, the CF -factor for gas (LNG) and the specific fuel consumption (SFC) of gas fuel shall be used by applying the criteria specified in paragraph 4.2.3 of the guidelines in item 9.2.2.2, as amended.
- .14 Notwithstanding paragraphs .12 and .13, in cases where overridable Shaft / Engine Power Limitation is installed, or in cases where engines do not have a test report included in the NO_x Technical File, SFC shall be calculated in accordance with paragraph 2.2.3 of the guidelines in item 9.2.5.1. For this purpose, actual performance records of the engine may be used if satisfactory and acceptable to the *Register*.
- 9.1.3.14** The *Register* may request the submitter for additional information as specified in 4.2.7 of the guidelines in 9.2.2.2, as necessary, to examine the calculation process of the attained EEXI.
- 9.1.3.15** In cases where the sea trial report as specified in 9.1.3.13.5 is submitted, the *Register* shall request further information from the submitter to confirm that:
- .1 the sea trial was conducted in accordance with the conditions specified in paragraphs 4.3.3, 4.3.4 and 4.3.7 of the guidelines in item 9.2.2.2, as applicable;
 - .2 sea conditions were measured in accordance with ISO 15016:2002 or the equivalent;
 - .3 ship speed was measured in accordance with ISO 15016:2002 or the equivalent; and
 - .4 the measured ship speed was calibrated, if necessary, by taking into account the effects of wind, tide, waves, shallow water and displacement in accordance with ISO 15016:2002 or the equivalent which may be acceptable provided that the concept of the method is transparent for the *Register* and publicly available/accessible.
- 9.1.3.16** The estimated speed-power curve obtained from the tank test and/or numerical calculations and/or the sea trial results calibrated by the tank test shall be reviewed on the basis of the relevant documents in accordance with the guidelines in 9.2.2.2, the defined quality standards (e.g. ITTC 7.5-03-01-02 and ITTC 7.5-03-01-04 in their latest revisions) and the verification of the numerical set-up with parent hull or the reference set of comparable ships.
- 9.1.3.17** In cases where the overridable Shaft / Engine Power Limitation system is installed, the *Register* shall confirm that the system is appropriately installed and sealed in accordance with the *2021 Guidelines on the Shaft / Engine Power Limitation system to comply with the EEXI requirements and use of a power reserve* (resolution MEPC.335(76), MEPC.375(80) and MEPC.390(81)) and that a verified Onboard Management Manual (OMM) for overridable Shaft / Engine Power Limitation is on board the ship.
- 9.1.3.18** In case where a major conversion is made to a ship, taking place at or after the completion date of the survey for EEXI verification, the revised EEXI Technical file shall be submitted to *Register* for verification.
- 9.1.3.19** The revised EEXI Technical file in case of a major conversion shall include the following:
- .1 details of the conversion;
 - .2 EEXI parameters changed after the conversion with relevant technical justifications for each parameter;

- .3 reasons for other changes made in the EEXI Technical file, if any;
- .4 calculated value of the attained EEXI with the calculation summary.

9.1.3.20 For verification of the attained EEXI after a major conversion, speed trials of the ship may be required, as necessary.

9.2 REQUIREMENTS ON ENERGY EFFICIENCY FOR SHIPS

9.2.1 Application

9.2.1.1 Item 9.2.2 and 9.2.3 shall apply to each new ship, each new ship which has undergone a major conversion and each new or existing ship which has undergone a major conversion, that is so extensive that the ship is regarded by the *Register* as a newly constructed ship.

9.2.1.2 Item 9.2.2 and 9.2.3 shall not apply to ships which have non-conventional propulsion, except cruise passenger ships having non-conventional propulsion and LNG carriers having conventional or non-conventional propulsion, delivered on or after 1st September 2019. Items 9.2.2 and 9.2.3 shall not apply to category A ships as defined in the Polar Code.

9.2.1.3 Item 9.2 shall not apply to ships not propelled by mechanical means and platforms including FPSO, FSU and drilling rigs, regardless of their propulsion.

9.2.1.4 From 1 January 2023 item 9.2.5 and 9.2.6 shall apply to each ship and each ship which has undergone a major conversion.

9.2.1.5 Item 9.2.5 and 9.2.6 shall not apply to ships which have non-conventional propulsion, except cruise

passenger ships having non-conventional propulsion and LNG carriers having conventional or non-conventional propulsion. Items 9.2.5 and 9.2.6, and item 9.4 shall not apply to category A ships as defined in the Polar Code.

9.2.2 Attained energy efficiency design index (Attained EEDI)

9.2.2.1 The attained EEDI shall be calculated taking into account guidelines in IMO Res. MEPC.364(79).

9.2.2.2 The attained EEDI shall be verified, based on the EEDI technical file, by the Register, taking into account guidelines in IMO Res. MEPC.365(79), MEPC.374(80) and **MEPC.403(83)**.

9.2.2.3 For each ship in 9.2.1.1, the Administration or any organization duly authorized by it shall report to the Organization the required and attained EEDI values and relevant information, taking into account the guidelines in 9.2.2.1 via electronic communication:

- .1 within 7 months of completing the survey required for IEEC issuance; or
- .2 within 7 months following 1 April 2022 for a ship delivered prior to 1 April 2022.

9.2.3 Required EEDI

9.2.3.1 The attained EEDI shall be as follows:

Attained EEDI \leq Required EEDI = $(1 - X/100) \times$ Reference line value

where,

X is the reduction factor specified in Table 9.2.3.1 for the required EEDI compared to the EEDI reference line.

Table 9.2.3.1
Reduction factor

SHIP TYPE	SIZE (DWT)	PHASE 0 1.1.2013.- 31.12.2014.	PHASE 1 1.1.2015.- 31.12.2019.	PHASE 2 1.1.2020.- 31.3.2022.	PHASE 2 1.1.2020.- 31.12.2024.	PHASE 3 1.4.2022. and onwards	PHASE 3 1.1.2025. and onwards
Bulk carrier	20000 and above	0	10		20		30
	10000-20000	N/a	0-10*		0-20*		0-30*
Gas carrier	15000 and above	0	10	20		30	
	10000-15000	0	10		20		30
	2000-10000	N/a	0-10*		0-20*		0-30*
Tanker	20000 and above	0	10		20		30
	4000-20000	N/a	0-10*		0-20*		0-30*
Container ship	200000 and above	0	10	20		50	
	120000-200000	0	10	20		45	
	80000-120000	0	10	20		40	
	40000-80000	0	10	20		35	
	15000-40000	0	10	20		30	
	10000-15000	N/a	0-10*	0-20*		15-30*	
General cargo ship	15000 and above	0	10	15		30	
	3000-15000	N/a	0-10*	0-15*		0-30*	
Refrigerated cargo carrier	5000 and above	0	10		15		30
	3000-5000	N/a	0-10*		0-15*		0-30*
Combination carrier	20000 and above	0	10		20		30
	4000-20000	N/a	0-10*		0-20*		0-30*
LNG carrier***	10000 and above	N/a	10**	20		30	
Ro-ro cargo ship (vehicle carrier)***	10000 and above	N/a	5**		15		30
Ro-ro cargo ship***	2000 and above	N/a	5**		20		30
	1000-2000	N/a	0-5***		0-20*		0-30*
Ro-ro passenger ship***	1000 and above	N/a	5**		20		30
	250-1000	N/a	0-5***		0-20*		0-30*
Cruise passenger ship*** having non-conventional propulsion	85000 GT and above	N/a	5**	20		30	
	25000-85000 GT	N/a	0-5***	0-20*		0-30*	

* Reduction factor to be linearly interpolated between the two values dependent upon vessel size.
N/a – means that no required EEDI applies.

** Phase 1 commences on 1st September 2015.

*** Reduction factor applies to ships delivered on or after 1st September 2019.

9.2.3.2 The attained EEDI, for each new or existing ship which has undergone a major conversion, that is so extensive that the ship is regarded by the Register as a newly constructed ship, shall be calculated with the reduction factor applicable corresponding to the ship type and size of the converted ship at the date of the contract of the conversion, or in the absence of a contract, the commencement date of the conversion.

9.2.3.3 The reference line values shall be calculated as follows:

$$\text{Reference line value} = a \times b^c$$

where *a*, *b* and *c* are the parameters given in Table 9.2.3.3

Table 9.2.3.3
Parameters for determination of reference line values

Ship type	<i>a</i>	<i>b</i>	<i>c</i>
Bulk carrier	961,79	DWT of the ship where DWT ≤ 279000 279000 where DWT > 279000	0,477
Gas carrier	1120,00	DWT of the ship	0,456
Tanker	1218,80	DWT of the ship	0,488
Container ship	174,22	DWT of the ship	0,201
General cargo ship	107,48	DWT of the ship	0,216
Refrigerated cargo carrier	227,01	DWT of the ship	0,244
Combination carrier	1219,00	DWT of the ship	0,488
Ro-ro cargo ship (vehicle carrier)	$(DWT/GT)^{0.7} \cdot 780,36$ where DWT/GT < 0,3 1812,63 where DWT/GT ≥ 0,3	DWT of the ship	0,471
Ro-ro cargo ship	1405,15	DWT of the ship	0,498
	1686,17 *	DWT of the ship where DWT ≤ 17000 * 17000 where DWT > 17000 *	
Ro-ro passenger ship	752,16	DWT of the ship	0,381
	902,59 *	DWT of the ship where DWT ≤ 10000 * 10000 where DWT > 10000 *	
LNG carrier	2253,7	DWT of the ship	0,474
Cruise passenger ship having non-conventional propulsion	170,84	GT of the ship	0,214

- to be used from phase 2 and thereafter

9.2.3.4 For each ship to which item 9.2.2 and 9.2.3 applies, the installed propulsion power shall not be less than the propulsion power needed to maintain the manoeuvrability of the ship under adverse conditions as defined in Guidelines in MEPC.1/Circ.850/Rev.3.

9.2.4 Ship energy efficiency management plan (SEEMP)

9.2.4.1 Each ship of 400 gross tonnage and above shall keep onboard a ship specific Ship energy efficiency management plan (SEEMP). It may form part of the ship's Safety management system (SMS).

9.2.4.2 The SEEMP shall be developed and reviewed taking into account guidelines in IMO Res. MEPC.395(82), as amended by MEPC.401(83).

9.2.4.3 On or before 31 December 2018, in the case of a ship of 5000 GT and above, the SEEMP shall include a description of the methodology that will be used to collect the data required by item 9.3.1 and the processes that will be used to report the data to the ship's administration.

9.2.4.4 The Administration shall ensure that for each ship to which item 9.3 applies, the SEEMP complies with 9.2.4.3. This shall be done prior to collecting data under 9.3 in order to ensure the methodology and processes are in place prior to beginning of the ship's first reporting period. Confirmation of compliance shall be provided to and retained onboard the ship.

9.2.4.5 In the case of a ship of 5,000 gross tonnage and above, which falls into one or more of the categories in MARPOL Annex VI, regulations 2.2.5, 2.2.7, 2.2.9, 2.2.11, 2.2.14 to 2.2.16, 2.2.22, and 2.2.26 to 2.2.29:

- .1 On or before 1 January 2023 the SEEMP shall include:
 - .1 a description of the methodology that will be used to calculate the ship's attained annual operational CII required by item 9.4 and the processes that will be used to report this value to the ship's Administration;
 - .2 the required annual operational CII, as specified in item 9.4, for the next three years;
 - .3 an implementation plan documenting how the required annual operational CII will be achieved during the next 3 years; and
 - .4 a procedure for self-evaluation and improvement.
- .2 For a ship rated as D for 3 consecutive years or rated as E, in accordance with item 9.4, the SEEMP shall be reviewed in accordance with item 9.4.4.2 to include a plan of corrective actions to achieve the required annual operational CII.
- .3 The SEEMP shall be subject to verification and company audits taking into

account the Guidelines in IMO Res. MEPC.347(78).

9.2.4.6 The Administration shall ensure that for each ship to which item 9.4 applies, the SEEMP complies with item 9.2.4.5.1. This shall be done prior to 1 January 2023. Confirmation of compliance shall be provided to and retained on board the ship.

9.2.5 Attained Energy Efficiency Existing Ship Index (attained EEXI)

9.2.5.1 The attained EEXI shall be calculated taking into account the Guidelines in IMO Res. MEPC.350(78).

The attained EEXI shall be specific to each ship and shall indicate the estimated performance of the ship in terms of energy efficiency, and be accompanied by the EEXI technical file that contains the information necessary for the calculation of the attained EEXI and that shows the process of the calculation.

The attained EEXI shall be verified, based on the EEXI technical file, either by the Administration or by any organization duly authorized by it taking into account the guidelines in IMO Res. MEPC.351(78).

9.2.5.2 Notwithstanding item 9.2.5.1, for each ship to which item 9.2.2 applies, the attained EEDI verified by the Administration or by any organization duly authorized by it in accordance with item 9.2.2.2 may be taken as the attained EEXI if the value of the attained EEDI is equal to or less than that of the required EEXI required by item 9.2.6. In this case, the attained EEXI shall be verified based on the EEDI Technical File.

9.2.6 Required EEXI

9.2.6.1 For each ship and each ship which has undergone a major conversion, which falls into one of the categories in MARPOL Annex VI, regulations 2.2.5, 2.2.7, 2.2.9, 2.2.11, 2.2.14 to 2.2.16, 2.2.22, and 2.2.26 to 2.2.29 and to which this Section is applicable, the attained EEXI shall be as follows:

$$\text{Attained EEXI} \leq \text{Required EEXI} = (1 - Y/100) \times \text{EEDI Reference line value}$$

where Y is the reduction factor specified in Table 9.2.6.1 for the required EEXI compared to the EEDI reference line.

Table 9.2.6.1
 Reduction factor

SHIP TYPE	SIZE (DWT)	REDUCTION FACTOR
Bulk carrier	200000 and above	15
	20000-200000	20
	10000-20000	0-20*
Gas carrier	15000 and above	30
	10000-15000	20
	2000-10000	0-20*
Tanker	200000 and above	15
	20000-200000	20
	4000-20000	0-20*
Container ship	200000 and above	50
	120000-200000	45
	80000-120000	35
	40000-80000	30
	15000-40000	20
	10000-15000	0-20*
General cargo ship	15000 and above	30
	3000-15000	0-30*
Refrigerated cargo carrier	5000 and above	15
	3000-5000	0-15*
Combination carrier	20000 and above	20
	4000-20000	0-20*
LNG carrier	10000 and above	30
Ro-ro cargo ship (vehicle carrier)	10000 and above	15
Ro-ro cargo ship	2000 and above	5
	1000-2000	0-5*
Ro-ro passenger ship	1000 and above	5
	250-1000	0-5*
Cruise passenger ship having non-conventional propulsion	85000 GT and above	30
	25000-85000 GT	0-30*

* Reduction factor to be linearly interpolated between the two values dependent upon ship size.

The lower value of the reduction factor is to be applied to the smaller ship size.

9.2.6.2 The EEDI reference line values shall be calculated in accordance with item 9.2.3.3. For ro-ro cargo ships and ro-ro passenger ships, the reference line value to be used

from phase 2 and thereafter under item 9.2.3.3 shall be referred to.

9.3 COLLECTION AND REPORTING OF SHIP FUEL OIL CONSUMPTION DATA

9.3.1 From calendar year 2019, each ship of 5.000 GT and above shall collect the following data (see appendix IX to Annex VI):

- identity of the ship: IMO number,
- period of calendar year for which the data is submitted: start date and end date;
- technical characteristics of the ship: year of delivery, ship type, gross tonnage, net tonnage, deadweight tonnage, power output (rated power) of main and auxiliary reciprocating internal combustion engines over 130 kW, attained EEDI/EEXI (if applicable), ice class (if applicable),
- total fuel oil consumption, by fuel oil type in metric tonnes and methods used for collecting fuel oil consumption data,
- total fuel oil consumption, by fuel oil type per consumer type in metric tonnes and methods used for collecting fuel oil consumption data,
- fuel oil consumption while the ship is not under way, by fuel oil type per consumer type in metric tonnes and methods used for collecting fuel oil consumption data,
- total distance travelled in nm,
- laden distance travelled in nm (on a voluntary basis),
- hours underway,
- total amount of onshore power supplied in kWh.

For ships to which item 9.4 applies:

- total transport work,
- applicable CII,
- required/attained annual operational CII,
- attained annual operational CII before any correction,
- installation of innovative technology (if applicable),
- operational carbon intensity rating,
- CII for trial purpose (on a voluntary basis),

for that and each subsequent calendar year or portion thereof, as appropriate, according to the methodology included in the SEEMP. The term portion thereof is to be applied according to IACS UI MPC 131. Guidance on the application of the amendments to Appendix IX of Annex VI is given in MEPC.1/Circ.913.

9.3.2 At the end of each calendar year, the ship shall aggregate the data collected in that calendar year or portion thereof, as appropriate.

9.3.3 Within three months after the end of each calendar year, the ship shall report to its Administration or any organization duly authorized by it, the aggregated value for each datum specified in 9.3.1, via electronic communication and using a standardized format shown in appendix 3 of IMO Res. MEPC.346(78).

9.3.4 In the event of the transfer of a ship from one Administration to another, in the event of a change from one company to another, or in the event of a change from one Administration to another and from one company to another concurrently, the ship shall on the day of completion of the transfer/change or as close as practical thereto report to the losing Administration/to its Administration or any organization duly authorized by it, the aggregated data for the portion of the calendar year corresponding to that Administration/to the company, as specified in 9.3.1 and upon request of the Administration, the disaggregated data.

9.3.5 The data shall be verified according to procedures established by the Administration, taking into account guidelines in IMO Res. MEPC.348(78) and MEPC.389(81).

9.3.6 The disaggregated data that underlies the reported data noted in 9.3.1 for the previous calendar year shall be readily accessible for a period of not less than 12 months from the end of that calendar year and be made available to the Administration upon request.

9.3.7 Upon receipt of reported data pursuant to 9.3.3 and 9.3.4, and attained annual operational CII pursuant to 9.4.1.2, the Administration or any organization duly authorized by it shall determine whether the data has been reported in accordance with 9.3, verify that the attained annual operational CII reported is based on the data submitted in accordance with 9.3; based on the verified attained annual operational CII, determine the operational carbon intensity rating of the ship in accordance with 9.4.3.1 and, if so, issue the Statement of Compliance related to fuel oil consumption reporting and operational carbon intensity rating to the ship. This statement shall be issued no later than five months from the beginning of the calendar year, or in the event of 9.3.4 this statement shall be issued promptly at the time of receipt of data.

Notwithstanding 9.3.7, a ship rated as D for 3 consecutive years or rated as E in accordance with 9.4 shall not be issued a Statement of Compliance unless a plan of corrective actions is duly developed and reflected in the SEEMP, and verified by the Administration or any organization duly authorized by it in accordance with 9.4.4.1 and 9.4.4.2.

9.3.8 The Statement of Compliance shall be drawn up in a form corresponding to the model given in appendix X to Annex VI.

9.3.9 The Statement of Compliance shall be valid for the calendar year in which it is issued and for the first five months of the following calendar year, or in the event of 9.3.4 this statement shall be valid for the calendar year in which it is issued, for the following calendar year and for the first five months of the subsequent calendar year. All Statements of Compliance shall be kept on board for at least 5 years.

9.3.10 The Administration shall ensure that the reported data noted in 9.3.1 by its registered ships of 5000 GT and above are transferred to the IMO Ship Fuel Oil Consumption Database via electronic communication and using a

standardized format developed by IMO not later than one month after issuing the Statements of Compliance of these ships.

9.3.11 IMO shall maintain an anonymized database such that identification of a specific ship will not be possible. Parties shall have access to the database strictly for their analysis and consideration. The Guidelines for database management are given in IMO Res. MEPC.349(78).

9.4 OPERATIONAL CARBON INTENSITY

9.4.1 Attained annual operational carbon intensity indicator (attained annual operational CII).

- .1 After the end of calendar year 2023 and after the end of each following calendar year, each ship of 5,000 gross tonnage and above, which falls into one or more of the categories in MARPOL Annex VI, regulations 2.2.5, 2.2.7, 2.2.9, 2.2.11, 2.2.14 to 2.2.16, 2.2.22, and 2.2.26 to 2.2.29, shall calculate the attained annual operational CII over a 12-month period from 1 January to 31 December for the preceding calendar year, using the data collected in accordance with item 9.3, taking into account the guidelines in IMO Res. MEPC.352(78).
- .2 Within 3 months after the end of each calendar year, the ship shall report to its Administration or any organization duly authorized by it, the attained annual operational CII, via electronic communication and using a standardized format to be developed by the Organization.
- .3 Notwithstanding 9.4.1.1 and 9.4.1.2 of this regulation, in the event of any transfer of a ship addressed in item 9.3.4 completed after 1 January 2023, a ship shall, after the end of the calendar year in which the transfer takes place, calculate and report the attained annual operational CII for the full 12-month period from 1 January to 31 December in the calendar year during which the transfer took place, in accordance with items 9.4.1.1 and 9.4.1.2, for verification in accordance with item 9.3.7, taking into account guidelines to be developed by the Organization. Nothing in this regulation relieves any ship of their reporting obligations under item 9.3 or 9.4.

9.4.2 Required annual operational carbon intensity indicator (required annual operational CII).

- .1 For each ship of 5,000 gross tonnage and above, which falls into one or more of the categories in MARPOL Annex VI, regulations 2.2.5, 2.2.7, 2.2.9, 2.2.11, 2.2.14 to 2.2.16, 2.2.22, and 2.2.26 to 2.2.29, the required annual operational CII shall be determined as follows:

$$\text{Required annual operational CII} = (1-Z/100) \times \text{CIIR}$$

where,

Z is the annual reduction factor to ensure continuous improvement of the ship's operational carbon intensity within a specific rating level; and CIIR is the reference value.

- .2 The annual reduction factor Z and the reference value CIIR shall be the values defined taking into account the guidelines in IMO Res. MEPC.338(76) as amended by MEPC.400(83), and IMO Res. MEPC.353(78).

9.4.3 Operational carbon intensity rating.

- .1 The Attained annual operational CII shall be documented and verified against the required annual operational CII to determine operational carbon intensity rating A, B, C, D or E, indicating a major superior, minor superior, moderate, minor inferior, or inferior performance level, either by the Administration or by any organization duly authorized by it, taking into account the Guidelines in IMO Res. MEPC.354(78). The middle point of rating level C shall be the value equivalent to the required annual operational CII set out in 9.4.2.1.

9.4.4 Corrective actions and incentives

- .1 A ship rated D for 3 consecutive years or rated as E shall develop a plan of corrective actions to achieve the required annual operational CII.
- .2 The SEEMP shall be reviewed to include the plan of corrective actions accordingly, taking into account the guidelines to be developed by the Organization. The revised SEEMP shall be submitted to the Administration or any organization duly authorized by it for verification, preferably together with, but in no case later than 1 month after reporting the attained annual operational CII in accordance with item 9.4.1.2.
- .3 A ship rated as D for 3 consecutive years or rated as E shall duly undertake the planned corrective actions in accordance with the revised SEEMP.
- .4 Administrations, port authorities and other stakeholders as appropriate, are encouraged to provide incentives to ships rated as A or B.

10 CONTROL AND MANAGEMENT OF SHIPS' BALLAST WATER AND SEDIMENTS

10.1 GENERAL REQUIREMENTS

10.1.1 General

Requirements of this Section are based on the *International convention for the control and management of ships' ballast water and sediments*, 2004. International convention for the control and management of ships' ballast water and sediments will enter into force on 8th September 2017.

10.1.2 Application

10.1.2.1 Requirements of this Section apply to ships engaged on international voyages designed or constructed to carry ballast water.

10.1.2.2 About application of this Section to ships engaged on voyages within area of navigation 3 and 4 decides Ministry specifically in every case, taking into account the Guidelines for risk assessment under regulation A-4 of BWM convention (G7), IMO Res. MEPC.289(71).

10.1.2.3 Intentionally blank.

10.1.3 Definitions

For the purpose of this Section, the following definitions apply:

10.1.3.1 Ballast water – means water with its suspended matter taken on board a ship to control trim, list, draught, stability or stresses of the ship.

10.1.3.2 Sediments – means matter settled out of ballast water within a ship.

10.1.3.3 Ballast water management – means mechanical, physical, chemical, and biological processes, either singularly or in combination, to remove, render harmless, or avoid the uptake or discharge of harmful aquatic organisms and pathogens within ballast water and sediments.

10.1.3.4 Harmful aquatic organisms and pathogens – means aquatic organisms or pathogens which, if introduced into the sea including estuaries, or into fresh water courses, may create hazards to the environment, human health, property or resources, impair biological diversity or interfere with other legitimate uses of such areas.

10.1.3.5 Active substance – means a substance or organism, including a virus or a fungus, that has a general or specific action on or against harmful aquatic organisms and pathogens.

10.1.3.6 Convention – means the International Convention for the Control and Management of Ships' Ballast Water and Sediments.

10.1.3.7 Certificate – means the International Ballast Water Management Certificate.

10.1.3.8 Anniversary date – means the day and the month of each year corresponding to the date of expiry of the certificate.

10.1.3.9 Ballast water capacity – means the total volumetric capacity of any tanks, spaces or compartments on a ship used for carrying, loading or discharging ballast water, including any multi-use tank, space or compartment designed to allow carriage of ballast water.

10.1.3.10 Constructed – in respect of a ship means a stage of construction where:

- .1 the keel is laid; or
- .2 construction identifiable with the specific ship begins; or
- .3 assembly of the ship has commenced comprising at least 50 tonnes or 1 percent of the estimated mass of all structural material, whichever is less; or
- .4 the ship undergoes a major conversion.

10.1.3.11 Major conversion – means a conversion of a ship:

- .1 which changes its ballast water carrying capacity by 15 percent or greater, or
- .2 which changes the ship type, or
- .3 which, in the opinion of the *Register*, is projected to prolong its life by ten years or more, or
- .4 which results in modifications to its ballast water system other than component replacement-in-kind. Conversion of a ship to meet the provisions of 10.2.6 shall not be deemed to constitute a major conversion for the purpose of this Section.

10.1.3.12 From the nearest land – means from the baseline from which the territorial sea of the territory in question is established in accordance with international law.

10.1.3.13 Ballast water management system (BWMS) – means any system which processes ballast water such that it meets or exceeds the ballast water performance standard in 10.2.7 The BWMS includes ballast water treatment equipment, all associated control equipment, monitoring equipment and sampling facilities.

10.1.3.14 Ballast water treatment equipment – means equipment which mechanically, physically, chemically, or biologically processes, either singularly or in combination, to remove, render harmless, or avoid the uptake or discharge of harmful aquatic organisms and pathogens within ballast water and sediments.

Ballast water treatment equipment may operate at the uptake or discharge of ballast water, during the voyage, or at a combination of these events.

10.1.3.15 Control equipment – means installed equipment required to operate and control the ballast water treatment equipment.

10.1.3.16 Monitoring equipment – means equipment installed for the assessment of the effective operation of the ballast water treatment equipment.

10.1.3.17 Sampling facilities – means equipment provided for sampling treated or untreated ballast water as needed in the BWMS Code and in the Guidelines for ballast water sampling (G2), IMO Res. MEPC.173(58).

10.1.3.18 Treatment rated capacity (TRC) – means the maximum continuous capacity expressed in cubic metres per hour for which the BWMS is type approved. It states the amount of ballast water that can be treated per unit time by the BWMS to meet the standard in 10.2.7.

10.1.3.19 Electronic record book – means a device or system, approved by the Administration, used to electronically record the entries for each ballast water operation as required under this Section of the Rules in lieu of a hard copy record book.

10.1.4 Scope of supervision

10.1.4.1 Intentionally blank.

10.1.4.2 Supervision during construction shall cover:

- .1 ballast water treatment equipment;
- .2 control and monitoring equipment;
- .3 systems for uptake, discharge and sampling of ballast water;
- .4 systems for transfer of ballast water to reception facilities, if applicable.

10.1.4.3 Technical documentation for ballast water management systems which shall be submitted to *Register* for approval shall include at least the following:

.1 BWMS technical specification, including at least:

- .1 description of the BWMS, treatment processes it employs and details of any required permits;
- .2 adequate information including descriptions and diagrammatic drawings of the pumping and piping arrangements, electrical/electronic wiring, monitoring system, waste streams and sampling points;
- .3 details of major components and materials used (including certificates where appropriate);
- .4 an equipment list showing all components subject to testing including specifications, materials and serial numbers;
- .5 an installation specification in accordance with manufacturers installation criteria requirements for the location and mounting of components, arrangements for maintaining the integrity of the boundary between safe and hazardous spaces and the arrangement of the sample piping;
- .6 information regarding the characteristics and arrangements in which the system is to be installed, including scope of the ships (sizes, types and operation) for which the system is intended; and
- .7 description of BWMS side streams (filtered material, centrifugal concentrate, waste or residual chemicals) including a description of the actions planned to

properly manage and dispose of such wastes;

.2 the operation, maintenance and safety manual, including at least:

- .1 instructions for the correct operation of the BWMS, including procedures for the discharge of untreated water in the event of malfunction of the ballast water treatment equipment;
- .2 instructions for the correct arrangement of the BWMS;
- .3 maintenance and safety instructions and the need to keep records;
- .4 troubleshooting procedures;
- .5 emergency procedures necessary for securing the ship;
- .6 any supplementary information considered necessary for the safe and efficient operation of the BWMS, documentation provided for approval under the procedure (G9); and
- .7 calibration procedures;

.3 information on any hazard identification conducted to identify potential hazards and define appropriate control measures, if the BWMS or the storage tanks for processing chemicals could emit dangerous gases or liquids;

.4 information regarding environmental and public health impacts including:

- .1 identification of potential hazards to the environment based on environmental studies performed to the extent necessary to assure that no harmful effects are to be expected;
- .2 in the case of BWMS that make use of active substances or preparations containing one or more active substances, the dosage of any active substances used and the maximum allowable discharge concentrations;
- .3 in the case of BWMS that do not make use of active substances or preparations, but which could reasonably be expected to result in changes to the chemical composition of the treated water such that adverse impacts to receiving waters might occur upon discharge, the documentation shall include results of toxicity tests of treated water as described in procedure (G9); and
- .4 sufficient information to enable the test organization to identify any potential health or environmental safety problems, unusual operating requirements (labour or materials), and any issues related to the disposal of treatment by-products or waste streams;

.5 information regarding system design limitations including:

- .1 identification of all known parameters to which the design of the BWMS is sensitive;
- .2 for each parameter the manufacturer shall claim a low and/or a high value for which the BWMS is capable of achieving the performance standard in 10.2.7; and

- .3 the proposed method for validating each claimed SDL shall be set out, together with information on the source, suitability and reliability of the method;
- .6 software change handling and revision control document including all software changes introduced to the system after the pre-test evaluation.
- .7 functional description, including a textual description with necessary supporting drawings, diagrams and figures to cover:
 - .1 system configuration and arrangement;
 - .2 scope of supply;
 - .3 system functionality covering control, monitoring, alarm and safety functions;
 - .4 self-diagnostics and alarming functionalities; and
 - .5 safe states for each function implemented.

10.2 MANAGEMENT AND CONTROL OF BALLAST WATER AND SEDIMENTS

10.2.1 Ballast water management plan

Each ship shall have on board and implement a Ballast water management plan. Such a plan shall be approved by the RO taking into account Guidelines for ballast water management and development of ballast water management plans (G4), IMO Res. MEPC.127(53), MEPC.306(73) and MEPC.370(80). The Ballast water management plan shall be specific to each ship and shall at least:

- .1 detail safety procedures for the ship and the crew associated with ballast water management;
- .2 provide a detailed description of the actions to be taken to implement the ballast water management requirements and supplemental ballast water management practices;
- .3 detail the procedures for the disposal of sediments at sea and to shore;
- .4 include the procedures for coordinating shipboard ballast water management that involves discharge to the sea with the authorities of the state into whose waters such discharge will take place;
- .5 designate the officer on board in charge of ensuring that the plan is properly implemented;
- .6 contain the reporting requirements for ships; and
- .7 be written in the working language of the ship. If the language used is not English, French or Spanish, a translation into one of these languages shall be included.

The Ballast water management plan may include contingency measures developed taking into account guidelines in BWM.2/Circ.62.

The Ballast water management plan shall include ship specific guidance and procedures, when operating

in challenging water quality, identified in IMO Res. MEPC.387(81).

In the case of use of temporary storage of treated sewage/grey water in ballast water tanks, the Ballast water management plan shall include ship specific change-over procedure, from ballast water storage to treated sewage/grey water storage and back to ballast water storage, including pump and piping associated with the dual purpose ballast water tanks, with specific details on how the flushing is conducted. Ballast water tanks to be used for temporary storage of treated sewage/grey water shall be identified in the Ballast water management plan. Guidance for the temporary storage of treated sewage and/or grey water in ballast water tanks is given in BWM.2/Circ.82.

10.2.2. Ballast water record book

- .1 Each ship shall have on board a Ballast water record book that may be an electronic record book, or that may be integrated into another record book or system, and which shall at least contain the information specified in appendix II of the Convention. Electronic record books shall be approved by the Administration taking into account the Guidelines in Res. MEPC.372(80).
- .2 Ballast water record book entries shall be maintained on board the ship for a minimum period of two years after the last entry has been made and thereafter in the company's control for a minimum period of three years.
- .3 Each operation concerning ballast water shall be fully recorded without delay in the Ballast water record book. Each entry shall be signed by the officer in charge of the operation concerned and each completed page shall be signed by the master or, in the case of a group of electronic entries, shall be verified by the master in a timely manner. The entries in the Ballast water record book shall be in a working language of the ship. If that language is not English, French or Spanish the entries shall contain a translation into one of those languages. Guidance on ballast water record-keeping and reporting is given in BWM.2/Circ.80/Rev.1.

10.2.3 Ballast water management for ships

- .1 A ship constructed before 2009:
 - .1 with a ballast water capacity of between 1500 and 5000 cubic metres, inclusive, shall conduct ballast water management that at least meets the standard described in 10.2.6 or 10.2.7 until the date of the renewal survey for the ship described in paragraph 10, after which time it shall at least meet the standard described in 10.2.7;
 - .2 with a ballast water capacity of less than 1500 or greater than 5000 cubic

- metres shall conduct ballast water management that at least meets the standard described in 10.2.6 or 10.2.7 until the date of the renewal survey for the ship described in paragraph 10, after which time it shall at least meet the standard described in 10.2.7.
- .2 A ship constructed in or after 2009 and before 8th September 2017, with a ballast water capacity of less than 5000 cubic metres shall conduct ballast water management that at least meets the standard described in 10.2.7, from the date of the renewal survey for the ship described in paragraph 10.
 - .3 A ship constructed in or after 2009, but before 2012, with a ballast water capacity of 5000 cubic metres or more shall conduct ballast water management that at least meets the standard described in 10.2.6 or 10.2.7 until the date of the renewal survey for the ship described in paragraph 10, after which time it shall at least meet the standard described in 10.2.7.
 - .4 A ship constructed in or after 2012 and before 8th September 2017 with a ballast water capacity of 5000 cubic metres or more shall conduct ballast water management that at least meets the standard described in 10.2.7, from the date of the renewal survey for the ship described in paragraph 10.
 - .5 A ship constructed on or after 8th September 2017 shall conduct ballast water management that at least meets the standard described in 10.2.7.
 - .6 The requirements of 10.2.3 do not apply to ships that discharge ballast water to a reception facility designed taking into account the Guidelines for ballast water reception facilities (G5), IMO Res. MEPC.153(55).
 - .7 Other methods of ballast water management may be accepted as alternatives to the standards described in 10.2.6 or 10.2.7, provided that such methods ensure at least the same level of protection to the environment, human health, property or resources, and are approved by the Organisation in accordance with Resolution MEPC.206(62).
 - .8 Ship constructed before 8th September 2017 to which the renewal survey described in paragraph 10 does not apply, shall conduct ballast water management that at least meets the standard described in 10.2.7 not later than 8 September 2024.
 - .9 Ships subject to 10.2.3.2, 10.2.3.4 or 10.2.3.8 shall comply with either standard described in 10.2.6 or 10.2.7, until such time after which they shall comply with standard described in 10.2.7.
 - .10 Renewal survey in 10.2.3.1, 10.2.3.2, 10.2.3.3 and 10.2.3.4 is:

- .1 the first renewal survey for the ship associated with the IOPP certificate on or after 8 September 2017 if:
 - .1 this survey is completed on or after 8 September 2019; or
 - .2 a renewal survey is completed on or after 8th September 2014 but prior to 8th September 2017; and
- .2 the second renewal survey for the ship associated with the IOPP certificate on or after 8th September 2017 if the first renewal survey on or after 8th September 2017 is completed prior to 8th September 2019.

10.2.4 Ballast water exchange

- .1 A ship conducting ballast water exchange to meet the standard in 10.2.6 shall:
 - .1 whenever possible, conduct such ballast water exchange at least 200 nautical miles from the nearest land and in water at least 200 metres in depth, taking into account the Guidelines for ballast water exchange (G6), IMO Res. MEPC.288(71) and MEPC.371(80);
 - .2 in cases where the ship is unable to conduct ballast water exchange in accordance with paragraph 1.1, such ballast water exchange shall be conducted taking into account the Guidelines (G6) and as far from the nearest land as possible, and in all cases at least 50 nautical miles from the nearest land and in water at least 200 metres in depth.
- .2 In sea areas where the distance from the nearest land or the depth does not meet the parameters described in paragraph 1.1 or 1.2, the port state may designate areas, in consultation with adjacent or other states, as appropriate, where a ship may conduct ballast water exchange, taking into account the Guidelines (G6).
- .3 Ships shall, without compromising safety or operational efficiency, be designed and constructed with a view to perform safe, environmentally acceptable, technically achievable, practicable and cost effective ballast water exchange, taking into account Guidelines for ballast water exchange design and construction standards (G11), IMO Res. MEPC.149(55).
- .4 When undertaking ballast water exchange operations master shall take into account guidelines in MSC/Circ.1145.

10.2.5 Sediment management for ships

- .1 All ships shall remove and dispose of sediments, from spaces designated to carry ballast water in accordance with the provisions of the ship's Ballast water management plan, to reception facilities designed

taking into account the Guidelines for sediment reception facilities (G1), IMO Res. MEPC.152(55).

- .2 Ships described in 10.2.3.3 to 10.2.3.6 shall, without compromising safety or operational efficiency, be designed and constructed with a view to minimize the uptake and undesirable entrapment of sediments, facilitate removal of sediments, and provide safe access to allow for sediment removal and sampling, taking into account Guidelines on design and construction to facilitate sediment control on ships (G12), IMO Res. MEPC.209(63). Ships described in 10.2.3.1 shall, to the extent practicable, comply with this paragraph.

10.2.6 Ballast water exchange standard

- .1 Ships performing ballast water exchange in accordance with 10.2.6 shall do so with an efficiency of at least 95 percent volumetric exchange of ballast water.
- .2 For ships exchanging ballast water by the pumping-through method, pumping through three times the volume of each ballast water tank shall be considered to meet the standard described in paragraph 1. Pumping through less than three times the volume may be accepted provided the ship can demonstrate that at least 95 percent volumetric exchange is met.

10.2.7 Ballast water performance standard

- .1 Ships conducting ballast water management in accordance with 10.2.7 shall discharge less than 10 viable organisms per cubic metre greater than or equal to 50 micrometres in minimum dimension and less than 10 viable organisms per millilitre less than 50 micrometres in minimum dimension and greater than or equal to 10 micrometres in minimum dimension; and discharge of the indicator microbes shall not exceed the specified concentrations described in paragraph 2.
- .2 Indicator microbes, as a human health standard, shall include:
 - .1 Toxicogenic *Vibrio cholerae* (O1 and O139) with less than 1 colony forming unit (cfu) per 100 millilitres or less than 1 cfu per 1 gram (wet weight) zooplankton samples ;
 - .2 *Escherichia coli* less than 250 cfu per 100 millilitres;
 - .3 Intestinal *Enterococci* less than 100 cfu per 100 millilitres.

10.2.8 Approval requirements for ballast water management systems

- .1 Except as specified in paragraph 2, ballast water management systems used to

comply with this Section must be approved by the *Register*, as follows:

- .1 taking into account Guidelines for approval of ballast water management systems (G8), IMO Res. MEPC.279(70), for systems installed before 28 October 2020.
- .2 taking into account Code for approval of ballast water management systems (BWMS Code), IMO Res. MEPC.300(72), for systems installed on or after 28th October 2020.
- .2 Ballast water management systems which make use of active substances or preparations containing one or more active substances to comply with this Section shall be approved by the Organization, based on the Procedure for approval of ballast water management systems that make use of active substances (G9), IMO Res. MEPC.169(57).
This procedure describes the approval and withdrawal of approval of active substances and their proposed manner of application. At withdrawal of approval, the use of the relevant active substance or substances shall be prohibited within 1 year after the date of such withdrawal.
- .3 Ballast water management systems used to comply with this Section must be safe in terms of the ship, its equipment and the crew.
- .4 Guidance on the procedure for evaluating an application for type approval of a ballast water management system and for evaluating modifications to an existing type approved ballast water management systems is given in BWM.2/Circ.43/Rev.2.

10.2.9 Prototype ballast water treatment technologies

- .1 For any ship that, prior to the date that the standard in 10.2.7 would otherwise become effective for it, participates in a programme approved by the *Register* to test and evaluate promising ballast water treatment technologies, the standard in 10.2.7 shall not apply to that ship until five years from the date on which the ship would otherwise be required to comply with such standard.
- .2 For any ship that, after the date on which the standard in 10.2.7 has become effective for it, participates in a programme approved by the *Register*, taking into account Guidelines for approval and oversight of prototype ballast water treatment technology programmes (G10), IMO Res. MEPC.140(54), to test and evaluate promising ballast water technologies with the potential to result in treatment

technologies achieving a standard higher than that in 10.2.7, the standard in 10.2.7 shall cease to apply to that ship for five years from the date of installation of such technology.

- .3 In establishing and carrying out any programme to test and evaluate promising ballast water technologies, parties shall:
 - .1 take into account Guidelines (G10), and
 - .2 allow participation only by the minimum number of ships necessary to effectively test such technologies.
- .4 Throughout the test and evaluation period, the treatment system must be operated consistently and as designed.

10.3 BALLAST WATER MANAGEMENT SYSTEMS

10.3.1 The BWMS shall not contain or use any substance of a dangerous nature, unless adequate arrangements for storage, application, installation and safe handling, acceptable to the *Register*, are provided to mitigate any hazards introduced thereby.

10.3.2 In case of any failure compromising the proper operation of the BWMS, audible and visual alarm signals shall be given in all stations from which ballast water operations are controlled.

10.3.3 All working parts of the BWMS that are liable to wear or to be damaged shall be easily accessible for maintenance. The routine maintenance of the BWMS and troubleshooting procedures shall be clearly defined by the manufacturer in the operating and maintenance manual. All maintenance and repairs shall be recorded.

10.3.4 To avoid interference with the BWMS, the following items shall be included:

- .1 every access of the BWMS beyond the essential requirements of paragraph 10.3.3, shall require the breaking of a seal;
- .2 if applicable, the BWMS shall be so constructed that a visual indication is always activated whenever the BWMS is in operation for purposes of cleaning, calibration, or repair, and these events shall be recorded by the control equipment;
- .3 any bypass of the BWMS shall activate an alarm, and the bypass event shall be recorded by the control equipment.

10.3.5 Facilities shall be provided for checking, at the renewal surveys and according to the manufacturer's instructions, the performance of the BWMS components that take measurements. A calibration certificate certifying the date of the last calibration check, shall be retained on board for inspection purposes. Only the manufacturer or persons authorized by the manufacturer shall perform the accuracy checks.

10.3.6 Ballast water treatment equipment

- .1 The ballast water treatment equipment shall be robust and suitable for working in the shipboard environment, shall be of a design and construction adequate for the service for which it is intended and shall be so installed and protected as to reduce to a minimum any danger to persons on board. Equipment that could emit dangerous gases / liquids shall have at least two independent means of detection and shut-down of the BWMS. Materials used in construction shall be compatible with the substances used, the purpose for which the equipment is intended, the working conditions to which it will be subjected and the environmental conditions on board.
- .2 The ballast water treatment equipment shall be provided with simple and effective

means for its operation and control. It shall be provided with a control system that shall be such that the services needed for the proper operation of the ballast water treatment equipment are ensured through the necessary arrangements.

- .3 The ballast water treatment equipment shall, if intended to be fitted in locations where flammable atmospheres may be present, comply with the relevant safety regulations for such spaces. Any electrical equipment that is part of the BWMS shall be based in a non-hazardous area, or shall be certified by the *Register* as safe for use in a hazardous area. Any moving parts, which are fitted in hazardous areas, shall be arranged so as to avoid the formation of static electricity.
- .4 BWMS shall be designed so as not to endanger the health and safety of the crew, interact negatively with the ship's systems and cargo or produce any adverse environmental effects. The BWMS shall not create long-term impacts on the safety of the ship and crew through corrosive effects in the ballast system and other spaces.
- .5 It shall be demonstrated, by using mathematical modelling and/or calculations, that any up or down scaling of the BWMS will not affect the functioning and effectiveness on board a ship of the type and size for which the equipment will be certified. In doing so, the manufacturer of the equipment shall take into account the guidance in BWM.2/Circ.33/Rev.1.
- .6 Scaling information shall allow the *Register* to verify that any scaled model is at least as robust as the land-based-tested model. The *Register* shall verify that the scaling used is appropriate for the operational design of the BWMS.
- .7 The shipboard test unit shall be of a capacity that allows for further validation of the mathematical modelling and/or calculations for scaling, and preferably selected at the upper limit of the rated capacity of the BWMS, unless otherwise approved by the *Register*.

10.3.7 Control and monitoring equipment

- .1 BWMS shall have a suitable control and monitoring system that will automatically monitor and record sufficient data to verify correct operation of the system. The equipment shall be able to produce a report of the applicable self-monitoring parameters for official inspections or maintenance, as required. Where practical, system design limitation parameters shall be monitored and recorded by the BWMS to ensure proper operation (see BWM.2/Circ.69).
- .2 The BWMS shall incorporate control and monitoring equipment that automatically

monitors and adjusts necessary treatment dosages or intensities or other aspects of the BWMS of the vessel, which while not directly effecting treatment, are nonetheless required for proper administration of the necessary treatment.

- .3 The monitoring equipment shall record the proper functioning or failure of the BWMS.
- .4 To facilitate compliance with 10.2.2, the control equipment shall also be able to store data for at least 24 months. In the event the control equipment is replaced, means shall be provided to ensure the data recorded prior to replacement remains available on board for 24 months.
- .5 All software changes introduced to the system after the pre-test evaluation shall be done according to a change handling procedure ensuring traceability.
- .6 For BWMS that could emit dangerous gases, means of gas detection by redundant safety systems shall be fitted in the space of the BWMS, and an audible and visual alarm shall be activated at a local area and at a manned BWMS control station in case of leakage. The gas detection device shall be designed and tested in accordance with IEC 60079-29-1 or other recognized standards acceptable to the *Register*. Monitoring measures for dangerous gases with independent shutdown shall be provided on the BWMS.

10.3.8 Installation requirements

- .1 The BWMS shall be provided with sampling facilities installed taking into account Guidelines (G2), so arranged in order to collect representative samples of the ship's ballast water discharge.
- .2 Suitable bypasses or overrides to protect the safety of the ship and personnel shall be installed and used in the event of an emergency and these shall be connected to the BWMS so that any bypass of the BWMS shall activate an alarm. The bypass event shall be recorded by the control and monitoring equipment and within the ballast water record book.
 This requirement does not apply to internal transfer of ballast water within the ship (anti-heeling operations). For BWMS that transfer water internally which may affect compliance with the standard in 10.2.7 (circulation or in-tank treatment), the recording required shall identify such internal transfer operations.
- .3 Installation of BWMS shall be in compliance with the *Rules for the classification of ships, Part 8 – Piping, 3.5*.

10.3.9 Workshop testing

Equipment, devices, systems and instrumentation after assembly shall be tested according to procedure in 10.1.4.3.9 approved by the *Register*. In special cases the *Register* may allow shipboard testing instead of workshop testing.

10.3.10 Installation survey and commissioning procedures

- .1 Verify that the following documentation is on board in a suitable format:
 - .1 a copy of the Type Approval Certificate of BWMS;
 - .2 a statement from *Register* or Flag State Administration, or from a laboratory authorized by the *Register* or Flag State Administration, to confirm that the electrical and electronic components of the BWMS have been type-tested in accordance with the specifications for environmental testing;
 - .3 equipment manuals for major components of the BWMS;
 - .4 an operations and technical manual for the BWMS specific to the ship and approved by the *Register*, containing a technical description of the BWMS, operational and maintenance procedures, and backup procedures in case of equipment malfunction;
 - .5 installation specifications;
 - .6 installation commissioning procedures; and
 - .7 initial calibration procedures.
- .2 Verify that:
 - .1 the BWMS installation has been carried out in accordance with the technical installation specification referred to in 10.3.10.1.5;
 - .2 the BWMS is in conformity with the Type Approval Certificate of BWMS issued by the *Register* or Flag State Administration;
 - .3 the installation of the complete BWMS has been carried out in accordance with the manufacturer's equipment specification;
 - .4 any operational inlets and outlets are located in the positions indicated on the drawing of the pumping and piping arrangements;
 - .5 the workmanship of the installation is satisfactory and, in particular, that any bulkhead penetrations or penetrations of the ballast system piping are to the relevant approved standards; and
 - .6 the installation commissioning procedures have been completed (see Guidance in BWM.2/Circ.70, Rev.1 and IACS Rec. No. 180 (Rev. 1, Nov. 2024)).