

**RULES  
FOR TECHNICAL SUPERVISION OF  
SEA-GOING SHIPS**

*Part 22 – POLLUTION PREVENTION*

**2019**

---

**CROATIAN REGISTER OF SHIPPING**

Hrvatska (Croatia) • 21000 Split • Marasovićeveva 67 • P.O.B. 187  
Tel.: (...) 385 (0)21 40 81 11  
Fax.: (...) 385 (0)21 35 81 59  
E-mail: [tech.coord@crs.hr](mailto:tech.coord@crs.hr)  
web site: [www.crs.hr](http://www.crs.hr)

**RULES FOR TECHNICAL SUPERVISION OF SEA-GOING SHIPS**  
Part 22 – POLLUTION PREVENTION

are considered to be applicable from 1<sup>st</sup> September 2019

**REVIEW OF MODIFICATIONS AND ADDITIONS IN RELATION TO  
January 2018 EDITION**

***RULES FOR TECHNICAL SUPERVISION OF SEA-GOING SHIPS  
Part 22 - POLLUTION PREVENTION***

All major changes in respect to January 2018 edition throughout the text are shaded (if any).

The grammar and print errors, have been corrected throughout the text of the Rules and are not subject to above indication of changes.

The subject Rules include the requirements of the following international organisations:

#### **International Maritime Organisation (IMO)**

<i>Conventions</i>	International Convention for the Prevention of Pollution from Ships 1973, as modified by the Protocol of 1978 relating thereto (MARPOL 73/78) and all subsequent amendments up to and including the 2018 amendments (MEPC.301(72)).  Protocol of 1997 to amend the International Convention for the Prevention of Pollution from Ships, 1973, as modified by the Protocol of 1978 relating thereto.  International Convention on the Control of Harmful Anti-fouling Systems on Ships, 2001. International Convention for the Control and Management of Ships' Ballast Water and Sediments, 2004.
<i>Resolutions</i>	A.446(XI), A.495(XII), A.497(XII), A.673(16), A.851(20), A.897(21), MEPC.5(XIII), MEPC.54(32), MEPC.58(33), MEPC.59(33), MEPC.71(38), MEPC.85(44), MEPC.86(44), MEPC.92(45), MEPC.96(47), MEPC.102(48), MEPC.103(49), MEPC.107(49), MEPC.108(49), MEPC.110(49), MEPC.128(53), MEPC.138(53), MEPC.139(53), MEPC.142(54), MEPC.148(54), MEPC.158(55), MEPC.159(55), MEPC.177(58), MEPC.185(59), MEPC.220(63), MEPC.227(64), MEPC.230(65), MEPC.232(65), MEPC.240(65), MEPC.243(66), MEPC.244(66), MEPC.245(66), MEPC.254(67), MEPC.255(67), MEPC.259(68), MEPC.261(68), MEPC.262(68), MEPC.263(68), MEPC.264(68), MEPC.272(69), MEPC.279(70), MEPC.281(70), MEPC.282(70), MEPC.284(70), MEPC.285(70), MEPC.291(71), MEPC.292(71), MEPC.293(71)
<i>Codes</i>	Code for Approval of Ballast Water Management Systems (BWMS Code), MEPC.300(72) Connection to IBC, BCH, IMDG, NOx and Polar Codes
<i>Circulars</i>	MEPC.1/Circ.642, MEPC.1/Circ.676, MEPC.1/Circ.680, MSC/Circ.585, BWM.2/Circ.70

#### **International Association of Classification Societies (IACS)**

<i>Unified Interpretations (UI)</i>	MPC 2 (Rev. 1, 2015), MPC 12 (Rev. 2, 2014; Corr. 1, 2014), MPC 14 (Rev. 1, 2014), MPC 20 (Rev. 1, 2014), MPC 29 (Rev. 1, 2014), MPC 88 (Rev. 1, 2015), MPC 103 (2013), MPC 105 (2013), MPC 106 (2015), MPC 108 to MPC 123 (2015), MPC 125 (2015), MPC 126 (2015), MPC 128 (2016)
<i>Procedural Requirements (PR)</i>	No. 38 (rev. 2, March 2019)

#### **European Union – European Parliament and Council**

<i>Regulations</i>	Regulation EC No.782/2003 of the European Parliament and of the Council of 14 <sup>th</sup> April 2003 on the prohibition of organotin compounds on ships  Regulation (EC) No 1005/2009 of the European parliament and of the Council of 16 <sup>th</sup> September 2009 on substances that deplete the ozone layer
<i>Directives</i>	Council Directive 1999/32/EC of 26 <sup>th</sup> April 1999 relating to a reduction in the sulphur content of certain liquid fuels as amended by the Directive 2005/33/EC

Contents:

	Page
<b>1 GENERAL .....</b>	<b>1</b>
1.1 GENERAL REQUIREMENTS .....	1
<b>2 PREVENTION OF POLLUTION BY OIL.....</b>	<b>3</b>
2.1 GENERAL REQUIREMENTS .....	3
2.2 OIL TANKERS .....	8
2.3 OIL FILTERING EQUIPMENT .....	15
2.4 OIL DISCHARGE MONITORING AND CONTROL SYSTEMS .....	16
2.5 OILY-WATER TRANSFER AND DISCHARGE SYSTEM OF PIPING .....	23
2.6 TANKS FOR OIL RESIDUES (SLUDGE) AND OILY-WATER(BILGE) OF A MACHINERY SPACE .....	25
2.7 SPECIAL REQUIREMENTS FOR FIXED OR FLOATING PLATFORMS .....	28
2.8 SHIPBOARD OIL POLLUTION EMERGENCY PLAN.....	29
2.9 STS OPERATIONS PLAN .....	29
<b>3 PREVENTION OF POLLUTION BY NOXIOUS LIQUID SUBSTANCES IN BULK.....</b>	<b>30</b>
3.1 GENERAL.....	30
3.2 CHEMICAL TANKER CONSTRUCTION.....	33
3.3 EQUIPMENT FOR PREVENTION OF POLLUTION .....	33
3.4 SHIPBOARD MARINE POLLUTION EMERGENCY PLAN FOR NOXIOUS LIQUID SUBSTANCES .....	37
<b>4 PREVENTION OF POLLUTION BY HARMFUL SUBSTANCES CARRIED BY SEA IN PACKAGED FORM.....</b>	<b>39</b>
<b>5 PREVENTION OF POLLUTION BY SEWAGE .....</b>	<b>40</b>
5.1 GENERAL.....	40
5.2 ARRANGEMENT AND EQUIPMENT FOR TREATMENT AND DISCHARGE OF SEWAGE.....	41
<b>6 PREVENTION OF POLLUTION BY GARBAGE.....</b>	<b>45</b>
6.1 GENERAL.....	45
6.2 ARRANGEMENT AND EQUIPMENT FOR COLLECTION AND PROCESSING OF GARBAGE AND INCINERATION OF WASTES .....	45
6.3 PLACARDS, GARBAGE MANAGEMENT PLANS, GARBAGE RECORD BOOK.....	48
<b>7 PREVENTION OF AIR POLLUTION .....</b>	<b>49</b>
7.1 GENERAL.....	49
7.2 SURVEY, CERTIFICATION AND MEANS OF CONTROL .....	51
7.3 REQUIREMENTS FOR CONTROL OF EMISSIONS FROM SHIPS .....	52
7.4 REQUIREMENTS OF NO <sub>x</sub> TECHNICAL CODE 2008 .....	58
<b>8 CONTROL OF HARMFUL ANTI-FOULING SYSTEMS ON SHIPS .....</b>	<b>69</b>
8.1 GENERAL REQUIREMENTS .....	69
8.2 HARMFUL ANTI-FOULING SYSTEMS ON SHIPS AND CONTROL MEASURES.....	69
8.3 SURVEY AND CERTIFICATION REQUIREMENTS FOR ANTI-FOULING SYSTEMS ON SHIPS.....	69
<b>9 ENERGY EFFICIENCY FOR SHIPS.....</b>	<b>70</b>
9.1 GENERAL.....	70
9.2 REQUIREMENTS ON ENERGY EFFICIENCY FOR SHIPS .....	71
9.3 COLLECTION AND REPORTING OF SHIP FUEL OIL CONSUMPTION daTa.....	73
<b>10 CONTROL AND MANAGEMENT OF SHIPS' BALLAST WATER AND SEDIMENTS.....</b>	<b>75</b>
10.1 GENERAL REQUIREMENTS .....	75
10.2 MANAGEMENT AND CONTROL OF BALLAST WATER AND SEDIMENTS .....	77
10.3 BALLAST WATER MANAGEMENT SYSTEMS.....	80

# 1 GENERAL

## 1.1 GENERAL REQUIREMENTS

### 1.1.1 Application

**1.1.1.1** *Rules for the technical supervision of sea-going ships, Part 22 - Prevention of Pollution* (hereinafter referred as: the Rules) of Croatian Register of Shipping (hereinafter referred to as: the *Register*), shall apply to new ships, namely:

- .1 Passenger ships, tankers intended for carriage of oil and other noxious or harmful substances and tugs, irrespective of the main engine of shaft output and gross tonnage;
- .2 Self-propelled ships, which are not specified in 1.1.1.1, with the main engine of the shaft output of 110 kW and over, if uses oil as a fuel;
- .3 Self-propelled ships, which are not specified in 1.1.1.1 and 1.1.1.2, of gross tonnage 50 tons and over.

**1.1.1.2** The present Rules may apply to ships not specified in 1.1.1, if the *Register* deems necessary, or approves.

**1.1.1.3** The present Rules shall apply to existing ships too, within extent specified in Chapters 2, 3, 4, 5, 6, 7, 8, 9 and 10 of present Rules.

**1.1.1.4** Possibilities for violation from the requirements, specified in 1.1.1 have been specified in the relevant Chapter of present Rules.

**1.1.1.5** When authorized by the Flag State Administration the *Register* will act on its behalf within limits of such authorization. When certifying systems and items of equipment falling under the scope of the Rules the *Register* will take into account any specific or additional requirements of the Flag State Administration.

Therefore, the Rules, or any part of it, should be applied only if the Flag State Administration has not provided the *Register* with written instruction to apply different interpretation. In the case of discrepancy between such national requirements and those of the *Rules* the former shall take precedence.

**1.1.1.6** All ships operating in polar waters shall comply with the environment related provisions of the introduction and with part II-A of the Polar Code, in addition to any other applicable requirements of these Rules. In applying part II-A, consideration should be given to the additional guidance in part II-B of the Polar Code.

### 1.1.2 Definitions

For the purposes of the present *Rules* the following definitions apply:

**1.1.2.1** **Rules** – means *Rules, Part 22 - the Prevention of Pollution*, including ten chapters as follows:

- Chapter 1 – General
- Chapter 2 – Prevention of Pollution by Oil

Chapter 3 – Prevention of Pollution by Noxious Liquid Substances in Bulk

Chapter 4 – Prevention of Pollution by Harmful Substances Carried by Sea in Packed Form

Chapter 5 – Prevention of Pollution by Sewage

Chapter 6 – Prevention of Pollution by Garbage

Chapter 7 – Prevention of Air Pollution

Chapter 8 – Control of harmful anti-fouling systems on ships

Chapter 9 – Energy efficiency for ships

Chapter 10 – Control and management of ships' ballast water and sediments.

**1.1.2.2** **Harmful substance** – means any substance which, if introduced into the sea, is liable to create hazards to human health, to harm living resources and marine life, to damage amenities or to interfere with other legitimate uses of the sea, and includes any substance subject to control by Convention MARPOL 73/78.

**1.1.2.3** **Discharge** – in relation to harmful substances or effluents containing such substances, means any release howsoever caused from a ship and includes any escape, disposal, spilling, leaking, pumping, emitting or emptying;

Discharge does not include:

- .1 dumping within the meaning of the Convention on the Prevention of Marine Pollution by Dumping of Wastes and Other Matter, done at London on 13th November 1972; or
- .2 release of harmful substances directly arising from the exploration, exploitation and associated offshore processing of seabed mineral resources; or
- .3 release of harmful substances for purposes of legitimate scientific research into pollution abatement or control.

**1.1.2.4** **Ship** – means a vessel of any type whatsoever operating in the marine environment and includes hydrofoil boats, air-cushion vehicles, submersibles, floating craft and fixed or floating platforms.

**1.1.2.5** **Administration** – means the Government of the State under whose authority the ship is operating.

With respect to a ship entitled to fly a flag of any State, the Administration is the Government of that State (i.e. *Flag State Administration*).

With respect to fixed or floating platforms engaged in exploration and exploitation of the sea-bed and subsoil thereof adjacent to the coast over which the coastal State exercises sovereign rights for the purposes of exploration and exploitation of their natural resources, the Administration is the Government of the coastal State concerned (i.e. *Coastal State Administration*).

**1.1.2.6** **Incident** – means an event involving the actual or probable discharge into the sea of a harmful substance, or effluents containing such a substance.

**1.1.2.7** **Organisation** – means the International Maritime Organisation (IMO).

**1.1.2.8** **MARPOL 73/78** – International Convention for the Prevention of Pollution from Ships, 1973, as modified by the Protocol of 1978 relating thereto and Amendments

contained (included) in MEPC Resolutions up-to-date. Hereinafter referred as *MARPOL 73/78* or *Convention*.

**1.1.2.9 MEPC** – Marine Environment Protection committee.

**1.1.2.10 Polar Code** – means the International Code for ships operating in polar waters.

**1.1.2.11 Category A ship** – means a ship designed for operation in polar waters in at least medium first-year ice, which may include old ice inclusions..

**1.1.2.12 Category B ship** – means a ship not included in category A, designed for operation in polar waters in at least thin first-year ice, which may include old ice inclusions.

**1.1.2.13 Category C ship** – means a ship designed to operate in open water or in ice conditions less severe than those included in categories A and B.

**1.1.2.14 Arctic waters** – means those waters determined in MARPOL 73/78, Annex I, Regulation 46.

**1.1.2.15 Polar waters** – means Arctic waters and/or the Antarctic area.

## 2 PREVENTION OF POLLUTION BY OIL

### 2.1 GENERAL REQUIREMENTS

#### 2.1.1 Application

**2.1.1.1** The present Chapter applies to performance, equipment, installations and systems provided for prevention of sea pollution by oil.

**2.1.1.2** Unless expressly provided otherwise, the requirements of this Chapter apply to:

- .1 all tankers, irrespective of gross tonnage, and
- .2 all ships which are not tankers of gross tonnage 50 tons and over and ships with the main engine shaft output of 110 kW and over, if uses oil as a fuel.

**2.1.1.3** **Intentionally blank.**

#### 2.1.2 Definitions

The explanation of terms and expressions, used in all chapters, is specified in Chapter 1 - General.

The following terms and expressions are applied in the present Chapter:

**2.1.2.1 Oil** – means petroleum in any form including crude oil, fuel oil, sludge, oil refuse and refined products (other than petrochemical which are subject to the provisions of Chapter 3).

**2.1.2.2 Crude oil** – means any liquid hydrocarbon mixture occurring naturally in the earth whether or not treated to render it suitable for transportation and includes:

- .1 crude oil from which certain distillate fractions may have been removed; and
- .2 crude oil to which certain distillate fractions may have been added.

**2.1.2.3 Oily mixture** – means a mixture with any oil content.

**2.1.2.4 Oil fuel** – means any oil used as fuel in connection with the propulsion and auxiliary machinery of the ship in which such oil is carried.

**2.1.2.5 Oil tanker** – means a ship constructed or adapted primarily to carry oil in bulk in its cargo spaces and includes combination carriers and any *chemical tanker* as defined in 3.1.2.1 when it is carrying a cargo or part cargo of oil in bulk.

**2.1.2.6 Crude oil tanker** – means an oil tanker engaged in the trade of carrying crude oil.

**2.1.2.7 Product carrier** – means an oil tanker engaged in the trade of carrying oil other than crude oil.

**2.1.2.8 Combination carrier** – means a ship designed to carry either oil or solid cargoes in bulk.

**2.1.2.9 Ship delivered after 31st December 1979** – means a ship:

- .1 for which the building contract is placed after 31st December 1975; or
- .2 in the absence of a building contract, the keel of which is laid or which is at a similar stage of construction after 30th June 1976; or
- .3 the delivery of which is after 31st December 1979; or
- .4 which has undergone a major conversion:
  - .1 for which the contract is placed after 31st December 1975; or
  - .2 in the absence of a contract, the construction work of which is begun after 30th June 1976; or
  - .3 which is completed after 31st December 1979.

**2.1.2.10 Ship delivered on or after 1st August 2010** – means a ship:

- .1 for which the building contract is placed on or after 1st August 2007; or
- .2 in the absence of a building contract, the keel of which is laid or which is at a similar stage of construction on or after 1st February 2008; or
- .3 the delivery of which is on or after 1st August 2010; or
- .4 which has undergone a major conversion:
  - .1 for which the contract is placed on or after 1st August 2007; or
  - .2 in the absence of a contract, the construction work of which is begun on or after 1st February 2008; or
  - .3 which is completed on or after 1st August 2010.

**2.1.2.11 Oil tanker delivered after 1st June 1982** – means an oil tanker:

- .1 for which the building contract is placed after 1st June 1979; or
- .2 in the absence of a building contract, the keel of which is laid or which is at a similar stage of construction after 1st January 1980; or
- .3 the delivery of which is after 1st June 1982; or
- .4 which has undergone a major conversion:
  - .1 for which the contract is placed after 1st June 1979; or
  - .2 in the absence of a contract, the construction work of which is begun after 1st January 1980; or
  - .3 which is completed after 1st June 1982.

**2.1.2.12 Oil tanker delivered on or after 6th July 1996** – means an oil tanker:

- .1 for which the building contract is placed on or after 6th July 1993; or
- .2 in the absence of a building contract, the keel of which is laid or which is at a similar stage of construction on or after 6th January 1994; or



- .3 the delivery of which is on or after 6th July 1996; or
- .4 which has undergone a major conversion:
  - .1 for which the contract is placed on or after 6th July 1993; or
  - .2 in the absence of a contract, the construction work of which is begun on or after 6th January 1994; or
  - .3 which is completed on or after 6th July 1996.

**2.1.2.13 Oil tanker delivered on or after 1st February 2002** – means an oil tanker:

- .1 for which the building contract is placed on or after 1st February 1999; or
- .2 in the absence of a building contract, the keel of which is laid or which is at a similar stage of construction on or after 1st August 1999; or
- .3 the delivery of which is on or after 1st February 2002; or
- .4 which has undergone a major conversion:
  - .1 for which the contract is placed on or after 1st February 1999; or
  - .2 in the absence of a contract, the construction work of which is begun on or after 1st August 1999; or
  - .3 which is completed on or after 1st February 2002.

**2.1.2.14 Oil tanker delivered on or after 1st January 2010** – means an oil tanker:

- .1 for which the building contract is placed on or after 1st January 2007; or
- .2 in the absence of a building contract, the keel of which is laid or which is at a similar stage of construction on or after 1st July 2007; or
- .3 the delivery of which is on or after 1st January 2010; or
- .4 which has undergone a major conversion:
  - .1 for which the contract is placed on or after 1st January 2007; or
  - .2 in the absence of a contract, the construction work of which is begun on or after 1st July 2007; or
  - .3 which is completed on or after 1st January 2010.

**2.1.2.15 Major conversion** – means a conversion of an existing ship:

- .1 which substantially alters the dimension or carrying capacity of the ship; or
- .2 which changes the type of the ship; or
- .3 the intent of which in the opinion of the *Register* is substantially to prolong its life; or
- .4 which otherwise so alters the ship that, if it were a new ship, it would become subject to relevant provisions of the present Rules not applicable to it as an existing ship.

Conversion of an oil tanker of 20 000 tons dead-weight and above delivered on or before 1<sup>st</sup> June 1982 to meet the requirements for segregated ballast tanks and for

protective location of segregated ballast tanks shall not be deemed to constitute a major conversion.

Conversion of an oil tanker delivered before 6<sup>th</sup> July 1996 to meet the requirements for double hull and double bottom shall not be deemed to constitute a major conversion.

**2.1.2.16 Constructed** – means a ship the keel of which is laid or which is at a similar stage of construction.

**2.1.2.17 Tank** – means an enclosed space which is formed by the permanent structure of a ship and which is designed for the carriage of liquid in bulk.

**2.1.2.18 Wing tank** – means any tank adjacent to the side shell plating.

**2.1.2.19 Centre tank** – means any tank inboard of a longitudinal bulkhead.

**2.1.2.20 Slop tank** – means a tank specifically designated for the collection of tank draining, tank washings and other oily mixtures.

**2.1.2.21 Clean ballast** – means the ballast in a tank which since oil was last carried therein, has been so cleaned that effluent therefrom if it were discharged from a ship which is stationary into clean calm water on a clear day would not produce visible traces of oil on the surface of the water or on adjoining shorelines or cause a sludge or emulsion to be deposited beneath the surface of the water or upon adjoining shorelines. If the ballast is discharged through an oil discharge monitoring and control system approved by the *Register*, evidence based on such a system to the effect that the oil content of the effluent did not exceed 15 parts per million shall be determinative that the ballast was clean, notwithstanding the presence of visible traces.

**2.1.2.22 Segregated ballast** – means the ballast water introduced into a tank which is completely separated from the cargo oil and oil fuel system and which is permanently allocated to the carriage of ballast or to the carriage of ballast or cargoes other than oil or noxious liquid substances as variously defined in the Chapter 3.

**2.1.2.23 Arrival ballast** – means clean ballast, see 2.1.2.21.

**2.1.2.24 Departure ballast** – means ballast other than arrival ballast.

**2.1.2.25 Water rinse** – means the water washing process carried out in connection with tank cleaning after crude oil washing and is not intended to be construed as limiting the amount of water needed in the process.

**2.1.2.26 Length *L*** – means 96% of the total length on a waterline at 85% of the least moulded depth measured from the top of the keel, or the length from the fore side of the stem to the axis of the rudder stock on that waterline, if that be greater. In ships designed with a rake of keel the waterline on which this length is measured shall be parallel to the designed waterline. The length *L* shall be measured in metres.

**2.1.2.27 Forward and after perpendiculars** – shall be taken at the forward and after ends of the length *L*. The forward perpendicular shall coincide with the fore side of the stem on the waterline on which the length is measured.

**2.1.2.28 Amidships** – is at the middle of the length *L*.

**2.1.2.29 Breadth *B*** – means the maximum breadth of the ship, measured amidships to the moulded line of the frame in a ship with a metal shell and to the outer surface of the hull in a ship with a shell of any other material. The breadth *B* shall be measured in metres.

**2.1.2.30 Dead-weight (DW)** - means the difference in tonnes between the displacement of a ship in water of a density of 1,025 t/m<sup>3</sup> at the load waterline corresponding to the assigned summer freeboard and the lightweight of the ship.

**2.1.2.31 Lightweight** – means the displacement of a ship in metric tons without cargo, fuel, lubricating oil, ballast water, fresh water and feed water in tanks, consumable stores, and passengers and crew and their effects, and including the weight of mediums onboard for the fixed fire-fighting systems.

**2.1.2.32 Volumes and areas** – in a ship shall be calculated in all cases to moulded lines.

**2.1.2.33 Special areas** – for the purpose of regulations in this Chapter, areas determined in MARPOL 73/78, Annex I, Regulation 1(11).

**2.1.2.34 Nearest land** – the term *from the nearest land* means from the baseline from which the territorial sea of the territory in question is established in accordance with international law.

**2.1.2.35 15 ppm bilge separator** – may include any combinations of a separator, filter, coalescer or other means, and also a single unit designed to produce an effluent with oil content not exceeding 15 ppm.

**2.1.2.36 15 ppm bilge alarm** – the alarm arrangements specified in regulation 2.4.2 are referred to in this Chapter as a 15 ppm Bilge Alarm.

**2.1.2.37 Automatic stopping device** – is a device used, where applicable, to automatically stop any discharge overboard of oily mixture when the oil content of the effluent exceeds 15 ppm.

**2.1.2.38 Parts per million (ppm)** – means parts of oil per million parts of water by volume.

**2.1.2.39 Oil discharge monitoring and control system** – is a system which monitors the discharge into the sea of oily ballast or other oil-contaminated water from the cargo tank areas and comprises the items specified in paragraph 2.4.3.2-3.

**2.1.2.40 Control section** – of a monitoring system is a unit composed of the items specified in paragraph 2.4.3.2-3 to 2.4.3.2-8.

**2.1.2.41 Overboard discharge control** – is a device which automatically initiates the sequence to stop the overboard discharge of the effluent in alarm conditions and prevents the discharge throughout the period the alarm condition prevails. The device may be arranged to close the overboard valves or to stop the relevant pumps, as appropriate.

**2.1.2.42 Starting interlock** – is a facility which prevents the initiation of the opening of the discharge valve or the operation of other equivalent arrangements before the monitoring system is fully operational when use of the monitoring system is required by the Convention.

**2.1.2.43 Control unit** – is a device which receives automatic signals of:

- .1 oil content of the effluent ppm;
- .2 flow rate of discharge m<sup>3</sup>/hour;
- .3 ship's speed in knots;
- .4 ship's position - latitude and longitude;
- .5 date and time (GMT); and
- .6 status of the overboard discharge control.

The unit shall make automatic recordings of data as specified in paragraph 2.4.3.9-.2.

**2.1.2.44 Instantaneous rate of discharge of oil content** – means the rate of discharge of oil in litres per hour at any instant divided by the speed of the ship in knots at the same instant.

### 2.1.3 Scope of supervision

#### 2.1.3.1 Intentionally blank.

**2.1.3.2** Supervision during construction shall cover:

- .1 Oil filtering equipment;
- .2 Oil-water interface detectors;
- .3 Crude oil washing system;
- .4 Oil discharge monitoring and control systems;
- .5 Systems for transfer of oil residues and oily water to reception facilities or other ships;
- .6 Systems for transfer, retaining and/or discharge of oily water overboard.

**2.1.3.3** Technical documentation which shall be submitted to *Register* for approval in addition to those referred to in 2.1.3.1, as appropriate:

- .1 technical description, method of work, instructions for operation and maintenance (for information);
- .2 general and functional scheme of equipment and system;
- .3 assembly drawing of the equipment or system with cross-sections, main scantlings and list of parts and materials;
- .4 drawings of essential parts of the equipment or system with indicated material properties as well as working and test pressure;
- .5 scheme for monitoring and control system;
- .6 basic electric schemes;
- .7 program for individual and type testing;
- .8 list of spare parts.

**2.1.3.4** The documentation of a monitoring system to be submitted to the *Register* for approval should include at least all the following:

- .1 a description of the monitoring system. The description should include a diagrammatic drawing of the pumping and piping arrangements, identifying the operational outlets for dirty ballast and oil-contaminated water from the cargo tank area and compatible with the operational requirements set out in the oil tanker's cargo and ballast handling manuals. Spe-

- cial considerations may have to be given to installations in oil tankers which have unusual pumping and piping arrangements;
- .2 equipment manuals, supplied by manufacturers, which should contain details of the major components of the monitoring system;
  - .3 an operations and technical manual for the complete monitoring system which is proposed to be installed in the oil tanker. This manual should cover the arrangements and operation of the system as a whole and should specifically describe parts of the system which are not covered by the manufacturer's equipment manuals;
  - .4 the operations section of the manual should include normal operational procedures and procedures for the discharge of oily water in the event of malfunction of the equipment;
  - .5 the technical section of the manual should include adequate information (description and diagrammatic drawings of the pumping and piping arrangements of the monitoring system and electrical/electronic wiring diagrams) to enable fault finding and should include instructions for keeping a maintenance record;
  - .6 a technical installation specification defining, *inter alia*, the location and mounting of components, arrangements for maintaining the integrity of the boundary between safe and hazardous spaces and the arrangement of the sample piping, including calculation of the sample response time referred to in 2.4.3.3-.6. The installation should comply with manufacturers specific installation criteria;
  - .7 a copy of the certificate of type approval for the oil content meter and technical documentation relevant to other main components of the monitoring system; and
  - .8 a recommended test and checkout procedure specific to the monitoring system installed. This procedure should specify all the checks to be carried out in a functional test by the installation contractor and should provide guidance for the surveyor when carrying out the on-board survey of the monitoring system and confirming the installation reflects the manufacturers specific installation criteria.

## 2.1.4 Workshop testing

**2.1.4.1** Equipment, installations and accessories after being assembled shall be tested on the test bench in compliance with the program approved by the *Register*. In particular cases *Register* may replace testing on the test bench with testing onboard ship.

**2.1.4.2** Each oil content meter and each control section of a monitoring system should be subjected to a functional test on a suitable test bench prior to delivery. The detailed programme for a functional test of such equipment should be developed by the manufacturer, taking into account the features and functions of the specific design of equipment. A completed workshop certificate including the delivery test protocol should be supplied with each unit delivered.

**2.1.4.3** A functional test conducted on an oil content meter should include at least all the following operations:

- .1 check flow rate, pressure drop, or an equivalent parameter as appropriate;
- .2 check all alarm functions built into the meter;
- .3 check all switching functions interconnecting with other parts of the system; and
- .4 check correct reading at several ppm values on all measurement scales when operated on an oil appropriate for the application of the meter or by an equivalent method.

**2.1.4.4** A functional check conducted on a control section of a monitoring system should include at least all the following operations:

- .1 check all alarm functions;
- .2 check correct function of the signal processor and the recording equipment when simulated input signals of ppm, flow rate, and speed are varied;
- .3 check that the alarm is activated when the input signals are varied so that the discharge limits contained in regulation 2.4.3.7-.2.1 and 2.4.3.7-.2.2 are exceeded;
- .4 check that a signal is given to the overboard discharge control when alarm conditions are reached; and
- .5 check that the alarm is activated when each one of the input signals is varied to exceed the capacity of the system.

## 2.1.5 On-board functional testing

**2.1.5.1** The functional test of the monitoring system referred to in 2.1.3.4-.8 should include at least all the following tests when the monitoring system is operating on water:

- .1 verify correct running of pumps, absence of leakage in the sample pumping and piping system, correct functioning of remote controlled sampling valves, etc.;
- .2 verify by checking flow rates or pressure drops, as appropriate, that the system operates under correct flow conditions. This test should be repeated separately for each sampling point;
- .3 verify that alarms function correctly when a malfunction occurs external to the monitoring system, such as no sample flow, no flow meter signal, power failure, etc.;
- .4 vary the simulated input signals manually while the monitoring system is operating on water and check the recordings for correct values and timing. Vary the simu-

lated manual input signals until alarm conditions are obtained, and verify proper recordings. Ascertain that the overboard discharge control is activating and verify that the action is being recorded;

- .5 verify that normal operating condition can be reset when the value of the instantaneous rate of discharge is reduced below 30 litres per nautical mile;
- .6 activate the manual override control and verify that a recording is made and that the overboard discharge control can be operated;
- .7 turn off the system and verify that the overboard discharge valve closes automatically or the relevant pumps are stopped and the overboard discharge control is inoperative;
- .8 start up the system and check the zero and gain setting for the oil content meter in accordance with the manufacturer's operations and technical manual; and
- .9 check the accuracy of the flow meter(s), for example by pumping water in a loop where the flow rate may be calculated from the level change in a tank. The check should be made at a flow rate of about 50% of the rated flow of the flow meter.

**2.1.5.2** To confirm the effectiveness of the crude oil washing system and stripping system, the crude oil washing operation should be witnessed to the satisfaction of the *Register*.

- .1 For ships that comply with MARPOL 73/78, Annex I, regulation 19(3), the crude oil washing operations are to be carried out using the approved crude oil washing equipment and as specified in the approved Operations and Equipment Manual. For at least one tank of a group of tanks of similar configuration, the *Register* should:
  - .1 confirm the operation of the stripping system by observing the monitoring devices and monitoring the oil level (by dipping or other means) during bottom washing;
  - .2 monitor the proper operation of the washing machines with particular reference to supply pressure, cycle times and machine function.

On completion of washing and final draining, the tanks are to be hand dipped, as close as practical to the forward end, centre and aft end in each tank and a record of these dips should be made in the Operations and Equipment Manual. The *Register* may require an internal examination as described in 2.1.5.2-2.1, or by an alternative method (e.g. video survey or other new technology) acceptable to the *Register*, if deemed necessary.

- .2 For ships other than those complying with MARPOL 73/78, Annex I, regulation 19(3), where fitted with cargo tanks in-

tended to be used in certain circumstances as ballast tanks, the following requirements apply in addition to those specified in 2.1.5.2-1:

- .1 To ensure that the tank is essentially free of clingage and deposits, the *Register* may require that the cleanliness of the tank be confirmed by a visual inspection made by entering the tanks after a crude oil washing but prior to any water rinse which may be specified in the Operations and Equipment Manual. If the tanks cannot be gas-freed for safe entry of the surveyor, an internal examination should not be conducted and the stripping test specified in 2.1.5.2-2.2 will be acceptable.

In this case, the bottom of the tank to be inspected may be flushed with water and stripped in order to remove any wedge of liquid crude oil remaining on the tank bottom before gas-freeing for entry. If the flushing procedure is adopted, a similar but unflushed tank must be used for the test specified in 2.1.5.2-2.2.

- .2 To verify the effectiveness of the stripping and drainage arrangements, a measurement should be made of the amount of oil floating on top of the departure ballast. The ratio of the volume of oil on top of the total departure ballast water to the volume of tanks that contain this water should not exceed 0,00085. This test should be carried out after crude oil washing and stripping in a tank similar in all relevant respects to the tank examined in accordance with 2.1.5.2-2.1, which has not been subjected to a water rinse or to the intervening water flushing permissible in 2.1.5.2-2.1.
- .3 To verify the design, installation and operation of the system, the arrival ballast, after a typical ballast voyage before which the arrival ballast tanks have been crude oil washed and during which the tanks have been water rinsed in accordance with the programme set out in the Operations and Equipment Manual, should be totally discharged to the loading port harbour through an oil discharged monitoring and control (ODM) system approved by the *Register*. The oil content of the effluent in this test should not exceed 15 ppm. Alternatively, the option of taking ballast water samples to be analysed in a shore-based laboratory is also acceptable.

This paragraph is not applicable to crude oil tankers of 20 000 tons dead-

weight and above delivered after 1<sup>st</sup> June 1982.

- .3 Where the *Register* is satisfied that ships are similar in all relevant respects, the requirements of 2.1.5.2-1 or 2.1.5.2-2 need only be applied to one such ship. Furthermore, where a ship has a series of tanks that are similar in all relevant respects then, for that series of tanks, the requirements of 2.1.5.2-1 need only be applied to one tank of that series.

## 2.1.6 General requirements

**2.1.6.1** Steel, forged, cast and welded parts as well as those of cast iron shall be manufactured and tested in compliance with the requirements of the *Rules for the classification of ships, Part 25 - Metallic materials* and *Part 26 - Welding*.

**2.1.6.2** Parts of equipment and installations which come in contact with the substances causing corrosion shall be of the corrosion-resistant materials or shall be with anti-corrosive protection.

**2.1.6.3** Automatic and remote control systems, measurement, monitoring and indication systems shall comply with the requirements of the *Rules for the classification of ships, Part 13 - Automation*.

**2.1.6.4** Pipelines, pipes and fittings of the equipment shall comply with the requirements of the *Rules for the classification of ships, Part 8 - Piping*.

**2.1.6.5** Electrical installation of the systems and equipment shall comply with the requirements of the *Rules for the classification of ships, Part 12 - Electrical installation*.

**2.1.6.6** Oily-water transfer pumps and washing systems shall comply with the requirements of the *Rules for the classification of ships, Part 9 - Machines*.

**2.1.6.7** Casings of separators, filters and other elements of the oily-water filtering equipment which are operating under pressure, shall comply with the requirements of the *Rules for the classification of ships, Part 10 - Boilers, Heat Exchangers and Pressure vessels*.

## 2.1.7 Segregation of oil and water ballast and carriage of oil in forepeak tanks

**2.1.7.1** In ships delivered after 31<sup>st</sup> December 1979 of 4000 gross tonnage and above other than oil tankers, and in oil tankers delivered after 31<sup>st</sup> December 1979 of 150 gross tonnage and above, no ballast water shall be carried in any oil fuel tank.

**2.1.7.2** For ships other than oil tankers fitted with cargo spaces which are constructed and utilised to carry oil in bulk of an aggregate capacity of 200 m<sup>3</sup> or more, the requirements of 2.1.7.1 for oil tankers shall also apply.

**2.1.7.3** In a ship of 400 gross tonnage and above, for which the building contract is placed after 1<sup>st</sup> January 1982 or, in the absence of a building contract, the keel of which is laid or which is at a similar stage of construction after 1<sup>st</sup> July

1982, oil shall not be carried in a forepeak tank or a tank forward of the collision bulkhead.

## 2.2 OIL TANKERS

### 2.2.1 Crude oil washing system

#### 2.2.1.1 General

- .1 Every crude oil tanker of 20 000 tons dead-weight and above delivered after 1<sup>st</sup> June 1982 shall be fitted with a cargo tank cleaning system using crude oil washing.
- .2 The system shall fully comply with the requirements of IMO Res. A.446(XI) as amended by IMO Res. A.497(XII) and resolution A.897(21) within one year after the tanker was first engaged in the trade of carrying crude oil or by the end of the third voyage carrying crude oil suitable for crude oil washing, whichever occurs later (see 2.1.5.2).
- .3 Every oil tanker operating with crude oil washing system shall be provided with an Operations and Equipment Manual detailing the system and equipment and specifying operational procedures, to the satisfaction of the *Register*.
- .4 Every oil tanker fitted with a cargo tank cleaning system using crude oil washing shall be provided with an inert gas system, according to *Rules for the classification of ships, Part 17 - Fire protection*.

#### 2.2.1.2 Piping

- .1 The crude oil washing pipes and all valves incorporated in the supply piping system shall be of steel or other equivalent material and shall be of adequate strength having regard to the pressure to which they may be subjected, and shall be properly jointed and supported. Piping is to comply with the requirements of *Rules for the classification of ships, Part 8 - Piping*.
- .2 The crude oil washing system shall consist of permanent piping and shall be independent of the fire mains and of any system other than for tank washing. A sections of the ship's cargo system may be incorporated in the crude oil washing system provided that they meet the requirements applicable to crude oil piping.
- .3 Notwithstanding the requirements of 2.2.1.2-.2 in combination carriers the arrangement of crude oil washing system may allow:

- .1 The removal of the equipment, if necessary, when carrying cargoes other than crude oil, provided that, when reinstated, the system is as originally fitted and tested for oil tightness;
- .2 The use of flexible hose pipes to connect the crude oil washing system to tank washing machines if it is necessary to locate these machines in a cargo tank hatch cover. Such flexible hose pipes must be provided with flanged connections and be manufactured and tested in accordance with the *Rules for the classification of ships, Part 8 - Piping*. The length of these hoses shall be no greater than necessary to connect the tank washing machines to an adjacent point just outside the hatch coaming. These hoses shall be removed to suitably prepared and protected stowage when not in use and be pressure tested by an authority acceptable to the *Register* at intervals of not more than two and a half years.
- .4 Provision shall be made to prevent overpressure in the tank washing supply piping. Any relief device fitted to prevent overpressure shall discharge into the suction side of the supply pump. Alternative methods to the satisfaction of the *Register* may be accepted provided an equivalent degree of safety and environmental protection is provided.  
One such alternative is that where the system is served only by centrifugal pumps so designed that the pressure derived cannot exceed that for which the piping is designed, a temperature sensing device located in the pump casing is required to stop the pump in the case of overheating.
- .5 Where hydrant valves are fitted for water washing purposes on tank washing lines, all such valves shall comply with 2.2.1.2-.1 and provision shall be made for such connections to be blanked off by blank flanges when washing lines may contain crude oil. Alternatively, hydrant valves shall be isolated from the crude oil washing system by spade blanks.
- .6 All connections for pressure gauges or other instrumentation shall be provided with isolating valves adjacent to the lines unless the fitting is of the sealed type.
- .7 No part of the crude oil washing system shall enter the machinery spaces. Where the tank washing system is fitted with a steam heater for use when water washing, the heater must be effectively isolated during crude oil washing by double shut-off valves or by clearly identifiable blanks.  
On oil tankers delivered after 1<sup>st</sup> June 1982 the steam heater referred to shall be located outside the machinery spaces. However, on an oil tanker delivered on or before 1<sup>st</sup> June 1982 with an existing steam heater located in the machinery spaces, no more additional isolation will be required other than that which isolates the crude oil washing system from the machinery spaces.
- .8 Where a combined crude oil-water washing supply piping is provided the piping shall be so designed that it can be drained so far as is practicable of crude oil, before water washing is commenced, into spaces designated in the *Operations and Equipment Manual*. These spaces may be the slop tank or other cargo spaces.
- .9 The piping system shall be of such diameter that the greatest number of tank cleaning machines required, as specified in 2.2.1.3-8, can be operated simultaneously at the designed pressure and throughput. The arrangement of the piping shall be such that the required number of tank cleaning machines to each cargo compartment, can be operated simultaneously.
- .10 The piping system shall be tested to 1,5 times the working pressure after it has been installed on the ship.
- .11 The crude oil washing supply piping shall be anchored (firmly attached) to the ship's structure at appropriate locations, and means shall be provided to permit freedom of movement elsewhere to accommodate thermal expansion and flexing of the ship. The anchoring shall be such that any hydraulic shock can be absorbed without undue movement of the supply piping.  
The anchors should normally be situated at the ends furthest from the entry of the crude oil supply to the supply piping. If tank washing machines are used to anchor the ends of branch pipes then special arrangements are necessary to anchor these sections when the machines are removed for any reason.

### 2.2.1.3 Tank washing machines

- .1 The tank washing machines for crude oil washing shall be permanently mounted and shall be of a design acceptable to the *Register*.
- .2 The performance characteristic of a tank washing machine is governed by nozzle diameter, working pressure and the movement pattern and timing. Each tank cleaning machine fitted shall have a char-

acteristic such that the sections of the cargo tank covered by that machine will be effectively cleaned within the time specified in the Operations and Equipment Manual.

- .3 Tank washing machines shall be mounted in each cargo tank and the method of support shall be to the satisfaction of the *Register*. Where the tank washing machines are positioned well below the deck level to cater for protuberances in the tank, consideration may need to be given to additional support for the machines and their supply piping.
- .4 Each machine shall be capable of being isolated by means of stop valves in the supply line. If a deck mounted tank washing machine is removed for any reason, provision shall be made to blank off the oil supply line to the machine for the period the machine is removed. Similarly, provision shall be made to close the tank opening with a plate or equivalent means. Where more than one submerged machine is connected to the same supply line a single isolating stop valve in the supply line may be acceptable provided the rotation of the submerged machines can be verified in accordance with 2.2.1.3-11.1 or 2.2.1.3-11.3.
- .5 Where the drive units for the tank cleaning machines are not integral with the tank cleaning machine, sufficient drive units shall be provided to ensure that no drive unit need be moved more than twice from its original position during cargo discharge to accomplish the washing programme as specified in the Operations and Equipment Manual. For crude oil tanker of 20 000 tons dead-weight and above, delivered after 1<sup>st</sup> June 1982 this is not applicable.
- .6 The number and location of the tank washing machines shall be to the satisfaction of *Register*.
- .7 The location of the machines is dependent upon the characteristics detailed in 2.2.1.3-2 and upon the configuration of the internal structure of the tank.
- .8 The number and location of the machines in each cargo tank and oily mixture (slop) tank shall be such that all horizontal and vertical areas are washed by direct impingement or effectively by deflection or splashing of the impinging jet. In assessing an acceptable degree of jet deflection and splashing, particular attention shall be paid to the washing of upward facing horizontal areas and the following parameters shall be used:

- .1 For horizontal areas of a tank bottom and the upper surfaces of a tank's stringers and other large primary structural members, the total area shielded from direct impingement by deck or bottom transverses, main girders, stringers or similar large primary structural members shall not exceed 10% of the total horizontal area of tank bottom, the upper surface of stringers, and other large primary structural members.
- .2 For vertical areas of the sides of a tank, the total area of the tank's sides shielded from direct impingement by deck or bottom transverses, main girders, stringers or similar large primary structural members shall not exceed 15% of the total area of the tank's sides.
- .3 For crude oil tankers delivered on or before 1 June 1982, the *Register* may permit the percentages required in 2.2.1.3-8.1 and 2.2.1.3-8.2 above to be exceeded for tanks having complicated internal structural members provided that the percentages calculated over all the cargo tanks do not exceed 10% for horizontal areas and 15% for vertical areas.

In some installations it may be necessary to consider the fitting of more than one type of tank washing machine in order to effect adequate coverage.

- .9 At the design stage the following minimum procedures shall be used to determine the area of the tank surface covered by direct impingement:
  - .1 Using suitable structural plans, lines are set out from the tips of each machine to those parts of the tank within the range of the jets.
  - .2 Where the configuration of the tanks is considered by the *Register* to be complicated, a pinpoint of light simulating the tip of the tank washing machine in a scale model of the tank shall be used.
  - .3 Shadow diagrams must be on drawings the scale of which must be at least:
    - .1 1:100 for tankers of less than 100 000 tons dead-weight
    - .2 1:200 for tankers of 100 000 tons dead-weight and above.
  - .4 The drawings must provide at least a plan view, a profile view and an end elevation for each tank, or for tanks considered to be similar.
  - .5 Sufficient detailed drawings of the vessel must be provided to check that all large primary structural members have been included.

- .6 Guidelines for the assessment of shadow diagrams are given in 4.2.9 of Appendix III to IMO resolution A.446(XI), as amended.
- .10 The design of the deck mounted tank washing machines shall be such that means are provided, external to the cargo tanks, which, when crude oil washing is in progress, would indicate the rotation and arc of the movement of the machine. Where the deck mounted machine is of the non-programmable, dual nozzle type, alternative methods to the satisfaction of the *Register* may be accepted provided an equivalent degree of verification is attained.
- .11 Where submerged machines are required, they should be non-programmable and, in order to comply with the requirements of 2.2.1.3-.8, it must be possible to verify their rotation by one of the following methods:
  - .1 By indicators external to the tank;
  - .2 By checking the characteristic sound pattern of the machine, in which case the operation of the machine shall be verified towards the end of each wash cycle.  
Where two or more submerged machines are installed on the same supply line, valves shall be provided and arranged so that operation of each machine can be verified independently of the other machines on the same supply line;
  - .3 By gas freeing the tank and checking the operation of the machine with water during ballast voyages.

The method of verification shall be stated in the *Operations and Equipment Manual*.

- .12 Fixed washing machines shall comply with the following:
  - .1 Stresses in piping or deck supports which arise during washing operation or when immersed into liquid shall not exceed allowable stresses.
  - .2 Machines shall be made of steel or other material which does not initiate sparking due to friction more than steel.
  - .3 Machines shall be earthed through hull.

#### 2.2.1.4 Pumps for crude oil washing system

- .1 The pumps supplying crude oil to the tank cleaning machines shall be either the cargo pumps or pumps specifically provided for the purpose.
- .2 The capacity of the pumps shall be sufficient to provide the necessary throughput at the required pressure for the maximum

number of tank cleaning machines required to be operated simultaneously as specified in the *Operations and Equipment Manual*. In addition to the above requirement, the pumps shall, if an eductor system is fitted for tank stripping, be capable of supplying the eductor driving fluid to meet the requirements of 2.2.1.5-.2.

- .3 The capacity of the pumps shall be such that the requirements of 2.2.1.4-.2 can be met with any one pump inoperative. The pumping and piping arrangements shall be such that the crude oil washing system can be effectively operated with any one pump out of use.
- .4 The carriage of more than one grade of cargo shall not prevent crude oil washing of tanks.
- .5 To permit crude oil washing to be effectively carried out where the back pressure presented by the shore terminal is below the pressure required for crude oil washing, provision shall be made that such an adequate pressure to the washing machines can be maintained in accordance with 2.2.1.4-.2. This requirement shall be met with any one cargo pump out of action. The minimum supply pressure required for crude oil washing shall be specified in the *Operations and Equipment Manual*. Should this minimum supply pressure not be obtainable, crude oil washing operations shall not be carried out.
- .6 Pumps shall be in accordance with the *Rules for the classification of ships, Part 8 - Piping* and *Part 9 - Machines*.

#### 2.2.1.5 Stripping system

- .1 The design of the system for stripping crude oil from the bottom of every cargo tank shall be to the satisfaction of the *Register*.
- .2 The design and capacity of the tank stripping system shall be such that the bottom of the tank being cleaned is kept free of accumulations of oil and sediment towards completion of the tank washing process.
- .3 The stripping system shall be capable of removing oil at a rate of 1,25 times the total throughput of all the tank cleaning machines to be operated simultaneously when washing the bottom of the cargo tanks or during any stage of the bottom washing as specified in the *Operations and Equipment Manual*.



- .4 Means such as level gauges, hand dipping and stripping system performance gauges as referred to in 2.2.1.5-.10 shall be provided for checking that the bottom of every cargo tank is dry after crude oil washing. Suitable arrangements for hand dipping must be provided at the aftermost portion of a cargo tank and in three other suitable locations unless other approved means are fitted for efficiently ascertaining that the bottom of every cargo tank is dry. The cargo tank bottom shall be considered *dry* if there is no more than a small quantity of oil near the stripping suction with no accumulation of oil elsewhere in the tank. Level indicators system shall be of closed type (water-gas tight).
- .5 Every oil tanker delivered after 1st June 1982, required to be provided with segregated ballast tanks or fitted with a crude oil washing system, shall comply with the following requirements:
- .1 Oil piping is to be so designed and installed that oil retention in the lines is minimised.
  - .2 Means shall be provided to drain all cargo pumps and all oil lines at the completion of cargo discharge, where necessary, by connection to a stripping device. The line and pump draining shall be capable of being discharged both to a cargo tank or a slop tank and ashore. For discharge ashore a special small diameter line shall be provided and shall be connected outboard of the ship's manifold valves. The cross-sectional area of this line shall not exceed 10% of that of a main cargo discharge line.
- .6 Every crude oil tanker delivered on or before 1 June 1982, required to be provided with segregated ballast tanks or fitted with a crude oil washing system, shall comply with 2.2.1.5-.5.2.
- Where small diameter line is already fitted on an oil tanker delivered on or before 1 June 1982, a cross-sectional area of not more than 25% of that of a main cargo discharge line may be accepted by the *Register*.
- .7 In crude oil tankers having individual cargo pumps in each tank, each pump having an individual piping system, dispensation from the required special small diameter line may be given in cases where the combined amount of oil left in the tank after stripping and the volume of oil in the piping system from the manifold to the tank is less than 0,00085 times the volume of the cargo tank. If a deep well cargo pump system is provided with an evacuating system for retained oil, the above consideration should also apply.
- .8 The means for stripping oil from the cargo tanks shall be by positive displacement pump, self-priming centrifugal pump or eductor or other methods to the satisfaction of the *Register*. Where a stripping line is connected to a number of tanks, means shall be provided for isolating each tank not being stripped at that particular time.
- .9 The internal structure of the tank shall be such that drainage of oil to the tank suctions of the stripping system is adequate to meet the requirements of 2.2.1.5-.2 and 2.2.1.5-.4. Care shall be taken that both longitudinal and transverse drainage are satisfactory and shall be verified during the inspection required by 2.1.5.2.
- .10 Equipment shall be provided for monitoring the efficiency of the stripping system. All such equipment shall have remote read-out facilities in the cargo control room or in some other safe and convenient place easily accessible to the officer in charge of cargo and crude oil washing operations. Where a stripping pump is provided, the monitoring equipment shall include, as appropriate, a flow indicator, or a stroke counter or a revolution counter, and pressure gauges at the inlet and discharge connections of the pump or equivalent. Where eductors are provided, the monitoring equipment shall include pressure gauges at the driving fluid intake and at the discharge and a pressure/vacuum gauge at the suction intake.
- .11 The trim conditions for crude oil washing given in the *Operations and Equipment Manual* shall be adhered to.
- .12 Connection of a small diameter line to the cargo manifold piping is given on figure 2.2.1.5-.12.

#### 2.2.1.6 Ballast lines

Where a separate ballast water system for ballasting cargo tanks is not provided, the arrangement shall be such that the cargo pump, manifolds and pipes used for ballasting can be safely and effectively drained of oil before ballasting.

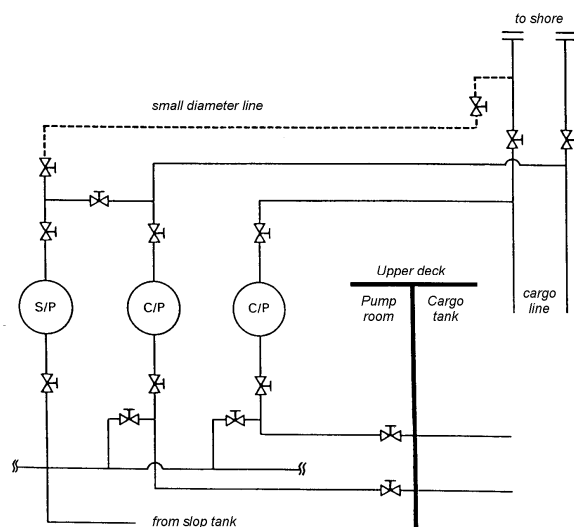

**Figure 2.2.1.5-12**  
**Connection of a small diameter line to the manifold piping**

## 2.2.2 Segregated ballast tanks

**2.2.2.1** Every crude oil tanker of 20,000 tons dead-weight and above and every product carrier of 30,000 tons dead-weight and above delivered after 1<sup>st</sup> June 1982 shall be provided with segregated ballast tanks.

**2.2.2.2** The capacity of the segregated ballast tanks shall be so determined that the ship may operate safely on ballast voyages without recourse to the use of cargo tanks for water ballast except as provided for in 2.2.2.3 or 2.2.2.4. In all cases, however, the capacity of segregated ballast tanks shall be at least such that, in any ballast condition at any part of the voyage, including the conditions consisting of light-weight plus segregated ballast only, the ship's draughts and trim can meet each of the following requirements:

- 1 the moulded draught amidships ( $d_m$ ) in metres (without taking into account any ship's deformation) shall not be less than:
 
$$d_m = 2,0 + 0,02 \cdot L \quad (2.2.2.2-1)$$
 where:  
 $L$ -length, see 2.1.2.26
- 2 the draughts at the forward and after perpendiculars shall correspond to those determined by the draught amidships ( $d_m$ ) as specified in formula 2.2.2.2-1, in association with the trim by the stern of not greater than  $0,015 L$ ; and
- 3 in any case the draught at the after perpendicular shall not be less than that which is necessary to obtain full immersion of the propeller(s).

Provision may be made for emergency discharge of the segregated ballast by means of a connection to a cargo pump through a portable spool piece. In this case non-return valves should be fitted on the segregated ballast connections to prevent the passage of oil to the segregated ballast tanks. The portable spool piece should be mounted in a conspicuous position in the pump-room and a permanent notice restricting its use should be prominently displayed adjacent to it.

**2.2.2.3** In no case shall ballast water be carried in cargo tanks, except:

- 1 on those rare voyages when weather conditions are so severe that, in the opinion of the master, it is necessary to carry additional ballast water in cargo tanks for the safety of the ship; and
- 2 in exceptional cases where the particular character of the operation of an oil tanker renders it necessary to carry ballast water in excess of the quantity required under paragraph 2.2.2.2, provided that such operation of the oil tanker falls under the category of exceptional cases as established by the Organisation.

Such additional ballast water shall be processed and discharged in compliance with 2.4.3 and an entry shall be made in the *Oil Record Book*, Part II.

**2.2.2.4** In the case of crude oil tankers delivered after 1<sup>st</sup> June 1982, the additional ballast permitted in 2.2.2.3 shall be carried in cargo tanks only if such tanks have been crude oil washed in accordance with 2.2.1 before departure from an oil unloading port or terminal.

**2.2.2.5** Three formulations are set forth as guidance concerning minimum draught requirements for segregated ballast tankers below 150 metres in length.

- 1 Formulation A
  - 1 mean draught =  $0,200 + 0,032 \cdot L$  [m]
  - 2 maximum trim =  $(0,024 - 6 \cdot 10^{-5} L) \cdot L$

The ballast conditions represent sailing condition in weather up to and including Beaufort 5.

- 2 Formulation B
  - 1 minimum draught at bow =  $0,700 + 0,0170 \cdot L$  [m]
  - 2 minimum draught at stern =  $2,300 + 0,030 \cdot L$  [m]
  - or
  - 3 minimum mean draught =  $1,550 + 0,023 \cdot L$  [m]
  - 4 maximum trim =  $1,600 + 0,013 \cdot L$  [m]

These formulae are based on a Sea 6 (International Sea Scale).

- 3 Formulation C
  - 1 minimum draught aft =  $2,0000 + 0,0275 \cdot L$  [m]
  - 2 minimum draught forward =  $0,5000 + 0,0225 \cdot L$  [m]

These expressions provide for certain increased draughts to aid in the prevention of propeller emergence and slamming in higher length ships.

**2.2.2.6** Subject to the provisions of 2.2.2.7 every crude oil tanker of 40 000 tons dead-weight and above delivered on or before 1<sup>st</sup> June 1982 shall be provided with segregated ballast tanks and shall comply with the requirements of 2.2.2.2 and 2.2.2.3.

**2.2.2.7** Crude oil tankers referred to in 2.2.2.6 may, in lieu of being provided with segregated ballast tanks, operate with a cargo tank cleaning procedure using crude oil washing in accordance with 2.2.1 unless the crude oil tanker is intend-

ed to carry crude oil which is not suitable for crude oil washing.

**2.2.2.8** Every product carrier of 40,000 tons dead-weight and above delivered on or before 1st June 1982 shall be provided with segregated ballast tanks and shall comply with the requirements of 2.2.2.2 and 2.2.2.3, or alternatively operate with dedicated clean ballast tanks in accordance with the following provisions:

- .1 The product carrier shall have adequate tank capacity, dedicated solely to the carriage of clean ballast to meet the requirements of 2.2.2.2 and 2.2.2.3.
- .2 The arrangements and operational procedures for dedicated clean ballast tanks shall comply with the requirements established by the *Register*. Such requirements shall contain at least all the provisions of the revised *Specifications for Oil Tankers with Dedicated Clean Ballast Tanks* adopted by the Organisation by resolution A.495(XII).
- .3 The product carrier shall be equipped with an oil content meter, approved by the *Register* on the basis of specifications recommended by the Organisation and 2.4.3, to enable supervision of the oil content in ballast water being discharged. The discharge of ballast from clean ballast tanks shall be continuously monitored. Recording of data and automatic operation of oil content meter is not required.
- .4 Every product carrier operating with dedicated clean ballast tanks shall be provided with a *Dedicated Clean Ballast Tank Operation Manual* detailing the system and specifying operational procedures. Such a Manual shall be to the satisfaction of the *Register* and shall contain all the information set out in the Specifications referred to in 2.2.2.8-2. If an alteration affecting the dedicated clean ballast tank system is made, the Operation Manual shall be revised accordingly.

**2.2.2.9** Item 2.2.2.6, 2.2.2.7 and 2.2.2.8 of this Chapter shall not apply to an oil tanker delivered on or before 1<sup>st</sup> June 1982 solely engaged in specific trades between:

- .1 ports or terminals within a State Party to the present Convention; or
- .2 ports or terminals of States Parties to the present Convention, where:
  - .1 the voyage is entirely within a Special Area; or
  - .2 the voyage is entirely within other limits designated by the Organisation.

Ports or terminals where cargo is loaded on such voyages are to be provided with reception facilities adequate for the reception and treatment of all the ballast and tank washing water from oil tankers.

**2.2.2.10** Any oil tanker which is not required to be provided with segregated ballast tanks in accordance with 2.2.2.1, 2.2.2.6 and 2.2.2.8 may, however, be qualified as a

segregated ballast tanker, provided that it complies with the requirements of 2.2.2.2 and 2.2.2.3 or 2.2.2.5 as appropriate.

**2.2.2.11** Oil tankers of 70,000 tonnes dead-weight and above delivered after 31<sup>st</sup> December 1979, as defined in 2.1.2.9, shall be provided with segregated ballast tanks and shall comply with 2.2.2.2, 2.2.2.3 and 2.2.2.4 or 2.2.2.5 as appropriate.

## 2.2.3 Oil tankers used for the storage of oil

**2.2.3.1** When an oil tanker is used for the storage of oil and its propulsion machinery arrangements have been so modified as to immobilise the ship, such a tanker is not required to comply with the provisions for segregated ballast tanks, clean ballast tanks, crude oil washing and double hull and double bottom.

**2.2.3.2** When an oil tanker is used as a floating facility to receive dirty ballast discharged from oil tankers, such a tanker is not required to comply with the provisions for segregated ballast tanks, clean ballast tanks, crude oil washing and double hull and double bottom.

## 2.2.4 Slop tanks

**2.2.4.1** Any oil tanker of 150 tons gross tonnage and above and ships other than oil tankers which are provided with tanks for carriage of oil of an aggregate capacity of 1000 m<sup>3</sup> and above shall be provided with slop tank arrangements in accordance with the requirements of paragraph 2.2.4.2, for cleaning the cargo tanks and transferring the dirty ballast residue and tank washings from the cargo tanks into a slop tank approved by the *Register*. In oil tankers delivered on or before 31<sup>st</sup> December 1979 any cargo tank may be designated as a slop tank.

In this system, arrangements shall be provided to transfer the oily waste into a slop tank or combination of slop tanks in such a way that any effluent discharged into the sea will be such as to comply with 2.4.

**2.2.4.2** The arrangements of the slop tank or combination of slop tanks shall have a capacity necessary to retain the slop generated by tank washings, oil residues and dirty ballast residues. The total capacity of the slop tank or tanks shall not be less than 3% of the oil carrying capacity of the ship, except that the *Register* may accept:

- .1 2% for such oil tankers where the tank washing arrangements are such that once the slop tank or tanks are charged with washing water, this water is sufficient for tank washing and, where applicable, for providing the driving fluid for eductors, without the introduction of additional water into the system;
- .2 2% where segregated ballast tanks or dedicated clean ballast tanks are provided or where a cargo tank cleaning system using crude oil washing is fitted in accordance with 2.2.1. This capacity may be further reduced to 1,5% for such oil tankers where the tank washing arrangements are such that once the slop tank or tanks are charge with washing water, this water is sufficient for tank washing and, where

applicable, for providing the driving fluid for eductors, without the introduction of additional water into the system; and

- .3 1% for combination carriers where oil cargo is only carried in tanks with smooth walls. This capacity may be further reduced to 0,8% where the tank washing arrangements are such that once the slop tank or tanks are charged with washing water, this water is sufficient for tank washing and, where applicable, for providing the driving fluid for eductors, without the introduction of additional water into the system.

**2.2.4.3** Oil tankers of 70,000 tons dead-weight and above delivered after 31st December 1979 shall be provided with at least two slop tanks.

**2.2.4.4** Slop tanks shall be so designed particularly in respect of the position of inlets, outlets, baffles or weirs where fitted, so as to avoid excessive turbulence and entrainment of oil or emulsion with the water.

**2.2.4.5** The requirements of 2.2.4.1 to 2.2.4.4 shall not apply to oil tankers of less than 150 gross tonnage, for which the control of discharge of oil under 2.4 shall be effected by the retention of oil on board with subsequent discharge of all contaminated washings to reception facilities. The total quantity of oil and water used for washing and returned to a storage tank shall be recorded in the Oil Record Book, Part II. This total quantity shall be discharged to reception facilities unless adequate arrangements are made to ensure that any effluent which is allowed to be discharged into the sea is effectively monitored to ensure that the provisions of 2.4 are complied with.

**2.2.4.6** The Administration may waive the requirements of 2.2.4.1 to 2.2.4.4 for any oil tanker which engages exclusively on voyages both of 72 hours or less in duration and within 50 nautical miles from the nearest land, provided that the oil tanker is engaged exclusively in trades between ports or terminals within a State Party to the present Convention. Any such waiver shall be subject to the requirement that the oil tanker shall retain on board all oily mixtures for subsequent discharge to reception facilities and to the determination by the Administration that facilities available to receive such oily mixtures are adequate.

**2.2.4.7** The requirements of 2.4.1.4, 2.4.4 and 2.2.4.1 to 2.2.4.4 shall not apply to oil tankers carrying asphalt or other products subject to the provisions of this Chapter, which through their physical properties inhibit effective product/water separation and monitoring, for which the control of discharge under 2.4 shall be effected by the retention of residues on board with discharge of all contaminated washings to reception facilities.

**2.2.4.8** If arrangements for machinery space bilge discharges into slop tanks are provided, they shall incorporate adequate means to prevent any backflow of liquid cargo and gases into the machinery spaces.

## 2.3 OIL FILTERING EQUIPMENT

### 2.3.1 General requirements

**2.3.1.1** Every ship of gross tonnage 400 tons and over but less than 10 000 tons shall be provided with an oil filtering equipment except those referred to in 2.6.3.

**2.3.1.2** Every ship less than 400 GT shall be provided with the equipment referred to in 2.3.1.1, or tanks referred to in 2.6.3, in agreement with the *Register*.

**2.3.1.3** Oil filtering equipment shall be designed to preclude the possibility of discharging the effluent with oil content exceeding 15 ppm and shall be type approved by the *Register*.

### 2.3.2 15 ppm bilge separator

**2.3.2.1** The 15 ppm Bilge Separator should be strongly constructed and suitable for shipboard use, bearing in mind its intended location on the ship. The 15 ppm bilge separator shall be capable of operating under ambient conditions set forth in the *Rules for the classification of ships, Part 7 - Machinery installation*, Chapter 1.6.

**2.3.2.2** It should, if intended to be fitted in locations where flammable atmospheres may be present, comply with the relevant safety regulations for such spaces. Any electrical equipment which is part of the 15 ppm Bilge Separator should be based in a non-hazardous area, or should be certified by the *Register* as safe for use in a hazardous area. Any moving parts which are fitted in hazardous areas should be arranged so as to avoid the formation of static electricity.

**2.3.2.3** Oil filtering equipment operating under pressure shall be provided with safety devices set to:

$$P_{sig} = 1,1 \cdot p \quad [\text{MPa}]$$

where:

$$p - \text{working pressure, [MPa]}$$

**2.3.2.4** The parts of oil filtering equipment operating under pressure are to be subjected to a hydraulic test referred to in the *Rules for the classification of Ships, Part 9 - Machines*, Chapter 1.3.

The parts are allowed to be separately tested with test pressure, which is determined on the basis of the working pressure.

**2.3.2.5** Parts and assemblies which are subject to periodical inspection and maintenance shall be easily accessible.

**2.3.2.6** Provisions shall be made to empty the oil filtering equipment.

**2.3.2.7** When the oil filtering equipment is designed with preheating of oily water, it shall be performed by means of steam or hot water coils. Electrical heating may be permitted provided that the requirements set forth in the *Rules for the classification of ships, Part 12 - Electrical equipment*, 15.3 are fulfilled.

**2.3.2.8** Oil filtering equipment shall be designed to function automatically. However, fail-safe arrangements to avoid any discharge in case of malfunction should be provided.

**2.3.2.9** Oil filtering equipment shall be fitted with pressure, temperature and level controls as well as alarm arrangements.

**2.3.2.10** Changing the feed to the 15 ppm Bilge Separator from bilge water to oil, bilge water to emulsified bilge water, or from oil and/or water to air should not result in the discharge overboard of any mixture containing more than 15 ppm of oil.

**2.3.2.11** The system should require the minimum of attention to bring it into operation. In the case of equipment used for engine room bilge, there should be no need for any adjustment to valves and other equipment to bring the system into operation. The equipment should be capable of operating for at least 24 hours of normal duty without attention.

**2.3.2.12** Oil filtering equipment may include any combination of a separator, filter or coalescer, and also a single unit designed to produce an effluent with oil content not exceeding 15 ppm.

**2.3.2.13** A centrifugal separator if included into oil filtering equipment, shall comply with the requirements of the *Rules for the classification of ships, Part 9 - Machines*, Chapter 5.4.

**2.3.2.14** Separators, filters, pumps and other equipment shall be fitted with trays where there is a possibility of oily water leakage, in accordance with the requirements of the *Rules for the classification of ships, Part 8 - Piping*, Chapter 8.5.

**2.3.2.15** The detailed requirements of oil filtering equipment are specified in the IMO Res. MEPC.107(49).

### 2.3.3 Installation requirements

**2.3.3.1** For future inspection purposes on board ship, a sampling point should be provided in a vertical section of the water effluent piping as close as is practicable to the 15 ppm bilge separator outlet.

Recirculating facilities should be provided to bilge or to oily bilge water tank, after and adjacent to the overboard outlet of the stopping device, to enable the oil filtering equipment, including the 15 ppm bilge alarm and the automatic stopping device, to be tested with the overboard discharge closed, see figure 2.3.3.1.

The recirculating facility should be so configured as to prevent under all operating conditions any by-pass of the oily water separator.

**2.3.3.2** The discharge piping system of the 15 ppm bilge water separator shall be completely separate from the bilge pumping and ballast water system.

**2.3.3.3** The capacity of the supply pump should not exceed 110% of the rated capacity of the 15 ppm Bilge Separator with size of pump and motor to be stated on the Certificate of Type Approval.

**2.3.3.4** The 15 ppm bilge separator should be fitted with a permanently attached plate giving any operational or installation limits considered necessary by the manufacturer or the *Register*.

**2.3.3.5** A vessel fitted with a 15 ppm Bilge Separator should, at all times, have on board a copy of the *Operating and Maintenance manual*.

## 2.4 OIL DISCHARGE MONITORING AND CONTROL SYSTEMS

### 2.4.1 General requirements

**2.4.1.1** Every ship of gross tonnage 10 000 tons and over as well as a ship of gross tonnage 400 tons and over carrying large quantity of fuel oil and which have to carry ballast water in fuel oil tanks, shall be provided with oil filtering equipment complying with 2.3.1.3.

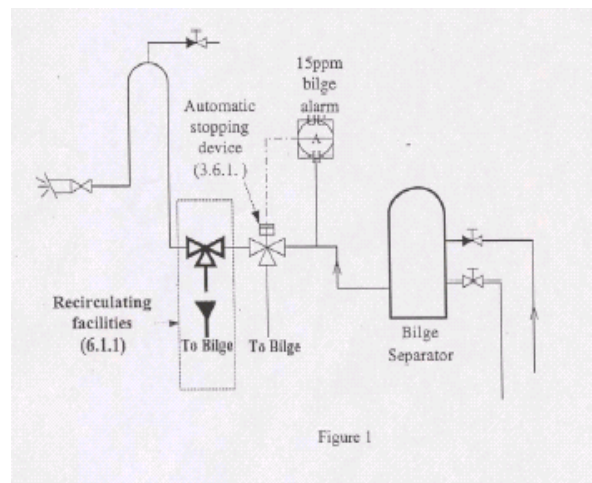

**Figure 2.3.3.1**  
Recirculating facilities

In addition it shall be provided with equipment in 2.4.2.

**2.4.1.2** Requirements in 2.4.1.1 shall not be mandatory for ships under conditions stated in 2.6.4.

**2.4.1.3** Ship may discharge oily mixture into the sea in special areas when provided with oil filtering equipment and monitoring and control of discharge when oil content of the effluent exceeds 15 ppm, in compliance with the requirements of 2.4.2.

**2.4.1.4** Oil tankers of gross tonnage 150 tons and above as well as ships other than oil tankers which are provided with tanks for carriage of oil of 1000 m<sup>3</sup> and above, shall be fitted with oil discharge monitoring and control system type approved by the *Register* (see 2.4.3). Ships other than oil tankers provided with the tanks intended for carriage of oil of an aggregate capacity of 200 m<sup>3</sup> to 1000 m<sup>3</sup> may retain oily mixtures on board with subsequent discharge to reception facilities.

**2.4.1.5** The requirement in 2.4.1.4 and 2.4.4 shall not be mandatory for:

- .1 Oil tankers engaged exclusively on voyages both of 72 hours or less in duration

and within 50 nautical miles from the nearest land, provided that the oil tanker is engaged exclusively in trades between ports or terminals within a State Party to the present Convention. Oil tankers shall retain on board all oily mixtures for subsequent discharge to reception facilities.

- .2 Oil tankers engaged exclusively in one or more voyages:
  - .1 within a special area, or
  - .2 within Arctic waters, or
  - .3 within 50 nautical miles from the nearest land, outside a special area or Arctic waters.
- .3 Oil tankers delivered on or before 1<sup>st</sup> June 1982, of 40 000 tons dead-weight or above, as referred to in 2.2.2.9.
- .4 Oil tankers of less than 150 gross tonnage as specified in 2.2.4.5.

**2.4.1.6** In Arctic waters any discharge into the sea of oil or oily mixtures from any ship shall be prohibited.

Subject to approval of the Administration, a category A ship constructed before 1<sup>st</sup> January 2017 that cannot comply with previous paragraph and is operating continuously in Arctic waters for more than 30 days shall comply with that paragraph not later than the first intermediate or renewal survey, whichever comes first, one year after 1<sup>st</sup> January 2017. Until such date these ships shall use oil filtering equipment in accordance with 2.4.2 for discharge into the sea of processed oil or oily mixtures from machinery spaces.

## **2.4.2 Equipment for monitoring and control of discharge of oily mixture from machinery spaces**

**2.4.2.1** The oily mixture, in case of oil tankers, is not to be mixed with oil cargo residues and is not to originate from cargo pump room bilge.

### **2.4.2.2 15 ppm bilge alarm**

- .1 The 15 ppm Bilge Alarm should resist corrosion in conditions of the marine environment.
- .2 The 15 ppm Bilge Alarm should, if intended to be fitted in locations where flammable atmosphere may be present, comply with the relevant safety regulations for such spaces. Any electrical equipment which is part of the 15 ppm Bilge Alarm should be placed in a non-hazardous area, or should be certified by the *Register* as safe for use in a hazardous atmosphere. Any moving parts which are fitted in hazardous areas should be arranged so as to avoid the formation of static electricity.
- .3 The 15 ppm Bilge Alarm should not contain or use any substance of a dangerous nature, unless adequate arrangements, acceptable to the *Register*, are provided to eliminate any hazards introduced thereby.
- .4 A ppm display should be provided. The ppm display should not be affected by

emulsions and/or the type of oil. It should not be necessary to calibrate the 15 ppm Bilge Alarm on board ship, but onboard testing according to the manufacturers instructions shall be permitted. The accuracy of the readings should at all times remain within  $\pm 5$  ppm.

- .5 The response time of the 15 ppm Bilge Alarm, that is, the time which elapses between an alteration in the sample being supplied to the 15 ppm Bilge Alarm and the ppm display showing the correct response, should not exceed 5 seconds.
- .6 The 15 ppm Bilge Alarm should be fitted with an electrical/electronic device which should be pre-set by the manufacturer to activate when the effluent exceeds 15 ppm. This should also operate automatically if at any time the 15 ppm Bilge Alarm should fail to function, require a warm-up period or otherwise be de-energised.
- .7 It is recommended that a simple means be provided aboard ship to check on instrument drift, repeatability of the instrument reading, and the ability to re-zero the instrument.
- .8 The 15 ppm Bilge Alarm should record date, time and alarm status, and operating status of the 15 ppm Bilge Separator. The recording device should also store data for at least eighteen months and should be able to display or print a protocol for official inspections as required. In the event the 15 ppm Bilge Alarm is replaced, means should be provided to ensure the data recorded remains available on board for 18 months.
- .9 To avoid wilful manipulation of 15 ppm Bilge Alarms, the following items should be included:
  - .1 every access of the 15 ppm Bilge Alarm beyond the essential requirements of paragraph .7 requires the breaking of a seal; and
  - .2 the 15 ppm Bilge Alarm should be so constructed that the alarm is always activated whenever clean water is used for cleaning or zeroing purposes.
- .10 The accuracy of the 15 ppm bilge alarms should be checked at IOPPC renewal surveys according to the manufacturers instructions. Alternatively the unit may be replaced by a calibrated 15 ppm bilge alarm. The calibration certificate for the 15 ppm bilge alarm should be checked for validity at IOPPC surveys. The accuracy checks can only be done by the manufacturer or persons authorized by the manufacturer by calibration and testing of the equipment at intervals not exceeding five years or within the term specified in the manufacturer's instructions, whichever is shorter.

**2.4.2.3 Automatic stopping device**

- .1 Electrical/electronic device shall give visual and audible alarm in cases stated in 2.4.2.2-6.
- .2 Visual and audible alarm arrangements shall be connected to the discharge control position.
- .3 The automatic stopping device should consist of a valve arrangement installed in the effluent outlet line of the 15 ppm Bilge Separator which automatically diverts the effluent mixture from being discharged overboard back to the ship's bilge or bilge tank when the oil content of the effluent exceeds 15 ppm, see figure 2.3.3.1.

**2.4.2.4 Installation requirements**

- .1 The layout of the installation should be arranged so that the overall response time (including the response time of the 15 ppm Bilge Alarm) between an effluent discharge from the 15 ppm Bilge Separator exceeding 15 ppm, and the operation of the Automatic Stopping Device preventing overboard discharge, should be as short as possible and in any case not more than 20 seconds.
- .2 The arrangement on board ship for the extraction of samples from the 15 ppm Bilge Separator discharge line to the 15 ppm Bilge Alarm should give a truly representative sample of the effluent with an adequate pressure and flow.
- .3 A vessel fitted with a 15 ppm Bilge Alarm should, at all times, have on board a copy of the Operating and Maintenance manuals.

**2.4.2.5** Detailed requirements of equipment for monitoring and control of discharge of oily mixture from machinery spaces are specified in the IMO Res. MEPC.107(49) and IMO Res. MEPC.285(70).

**2.4.3 Oil discharge monitoring and control system****2.4.3.1 General requirements**

- .1 Detailed requirements for this equipment are specified in IMO Res. MEPC.108(49) and IMO Res. MEPC.240(65). Bio-fuel blends containing 75% or more of petroleum oil, on or after 1<sup>st</sup> January 2016, may be carried when the ship's ODME is in compliance with IMO Res. MEPC.240(65).
- .2 Oil discharge monitoring and control system shall be capable of working under ambient conditions referred to in the *Rules for the classification of ships, Part 7 - Machinery installation*, Chapter 1.6 and of complying with the requirements

in the *Rules for the classification of ships, Part 12 - Electrical Equipment*, paragraph 5.1.3 and *Part 13 - Automation*, Chapter 2.5.

- .3 Oil Discharge Monitoring and Control System should employ a control unit and be fitted with a starting interlock and overboard discharge control. System shall come into operation when there is any discharge of effluent into the sea and shall ensure that any discharge of oily mixture is automatically stopped when the instantaneous rate of discharge of oil exceeds that permitted in 2.4.3.7-2.
- .4 Any failure of the system shall stop the discharge. In case of failure in the system, a manually operated alternative method in accordance with 2.4.3.11 may be used.
- .5 The instrument should be designed to ensure that user access is restricted to essential controls. Access beyond these controls should be available for emergency maintenance and temporary repair but must require the breaking of security seals or activation of another device which indicates an entry to the equipment.  
The seals should be of a design that only the manufacturer or his agent can replace the seals or reset the system following inspection and permanent repairs to the equipment.
- .6 The unit may have several scales as appropriate for its intended use. The recording device fitted to a meter which has more than one scale should indicate the scale which is in use.
- .7 It is recommended that simple means be provided aboard ship to check on instrument drift, repeatability of the instrument reading, and the ability to re-zero the instrument.
- .8 Manufacturer recommended spares for the ODME should be carried to ensure the operation of the equipment.
- .9 Instructions as to the operation of the system shall be in accordance with an operational manual approved by the *Register*. They shall cover manual as well as automatic operations and shall be intended to ensure that at no time shall oil or oily mixtures be discharged except in compliance with the conditions specified in 2.4.3.7-2. The routine maintenance of the Oil Discharge Monitoring Equipment and troubleshooting procedures should be clearly defined by the manufacturer in the *Operating and Maintenance Manual*. Oil discharge monitoring and control system operational manual is to contain all

the details necessary to operate and maintain the system and shall include at least the information as indicated in IACS UI MPC2.

#### 2.4.3.2 Monitoring and control system

- .1 The monitoring system should be capable of effectively monitoring and controlling the discharge of any effluent into the sea through those overboard discharge outlets permitted by 2.5.1 which, in the opinion of the *Register*, are necessary to fulfil the operational requirements of the oil tanker.
- .2 The monitoring system should function effectively under all environmental conditions which oil tankers are normally assumed to encounter, and should be designed and constructed to satisfy the specifications for environmental testing specified in part 2 of the annex to Guidelines and Specifications contained in IMO Res. MEPC.108(49). Moreover:
  - .1 the system should be so designed that no discharge of dirty ballast or other oil-contaminated water from the cargo tank areas can take place unless the monitoring system is in the normal operating mode and the relevant sampling point has been selected;
  - .2 preferably the system should sample the effluent discharge from a minimum number of discharge outlets and be so arranged that discharge overboard can take place via only one outlet at a time;
  - .3 where it is intended that more than one line be used for simultaneous discharging purposes, one oil content meter, together with a flow meter, should be installed in each discharge line. These instruments should be connected to a common processor; and
  - .4 in order to avoid alarms due to short-term high oil concentration signals (spikes) causing indications of high instantaneous rates of discharge, the short-term high ppm signal may be suppressed for a maximum of 10 s. Alternatively, the instantaneous rate of discharge may be continuously averaged during the preceding 20 s or less as computed from instantaneous ppm values of the oil content meter readings received at intervals not exceeding 5 s.
- .3 The monitoring system should comprise:
  - .1 an oil content meter to measure the oil content of the effluent in ppm. The meter should be approved in accordance with the provisions contained in

the annex to Guidelines and Specifications contained in IMO resolution MEPC.108(49) and be certified to take into account the range of cargoes carried;

- .2 a flow rate indicating system to measure the rate of effluent being discharged into the sea;
- .3 a ship speed indicating device to give the ship's speed in knots;
- .4 a ship position indicating device to give the ship's position, latitude and longitude;
- .5 a sampling system to convey a representative sample of the effluent to the oil content meter;
- .6 an overboard discharge control to stop the overboard discharge;
- .7 a starting interlock to prevent the discharge overboard of any effluent unless the monitoring system is fully operational; and
- .8 a control section comprising:
  - .1 a processor, which accepts signals of oil content in the effluent, the effluent flow rate and the ship's speed and computes these values into litres of oil discharged per nautical mile and the total quantity of oil discharged;
  - .2 means to provide alarms and command signals to the overboard discharge control;
  - .3 a recording device to provide a record of data in accordance with 2.4.3.9;
  - .4 a data display to exhibit the current operational data in accordance with 2.4.3.10;
  - .5 a manual override system to be used in the event of failure of the monitoring system; and
  - .6 means to provide signals to the starting interlock to prevent the discharge of any effluent before the monitoring system is fully operational.
- .4 Each main component of the oil content monitoring system should be fitted with a name-plate, properly identifying the component by assembly drawing number, type or model number and serial number, as appropriate.
- .5 If installed in a hazardous area, the electrical components of the monitoring system should meet the appropriate safety requirements laid down for these areas.

#### 2.4.3.3 Oil content meter

- .1 An oil content meter should satisfy the test and performance specifications contained in part 1 of the Annex to Guidelines and Specifications contained in IMO



Res. MEPC.108(49) and should conform with the general requirements contained in 2.4.3.3.

- .2 The accuracy of meters designed to monitor a wide range of oil content should be such that the reading will represent the actual oil content of the sample being tested within  $\pm 10$  ppm or  $\pm 10\%$ , whichever is greater. The accuracy should remain within the above limit despite the presence of contaminants other than oil, such as entrained air, rust, mud and sand.
- .3 The meter should be designed so that it functions within the above limit when the power supply (in the form of electricity, compressed air, etc.) is varied by 10% from the value for which the meter is designed.
- .4 It is desirable that the reading should not be affected by the type of oil. If it is, it should not be necessary to calibrate the meter on board ship, but pre-set alterations in the calibration may be made in accordance with the manufacturer's instructions. In the latter case, means should be available to check that the correct calibration has been selected for the oil in question. The accuracy of the readings should at all times remain within the limit specified in 2.4.3.3-2.
- .5 The meter may have several scales as appropriate for its intended use. The full range of the scale shall not be less than 1000 ppm.
- .6 The response time of the meter shall not exceed 20 seconds.
- .7 The meter shall have simple means to enable the ship's crew to check the functioning of the electrical and electronic circuitry of the meter by introduction of a simulated signal corresponding approximately to half the full scale reading of the meter. It shall also be possible for qualified personnel to recalibrate the meter on board the oil tanker.
- .8 The meter should, if intended to be fitted in locations where flammable atmospheres may be present, comply with the relevant safety regulations for such spaces. Any electrical equipment which is part of the meter should be placed in a non-hazardous area, or should be certified by the *Register* as safe for use in a hazardous atmosphere. Any moving parts which are fitted in hazardous areas should be so arranged as to avoid the formation of static electricity.
- .9 The meter should not contain or use any substance of a dangerous nature, unless adequate arrangements, acceptable to the

*Register*, are provided to eliminate any hazard introduced thereby.

- .10 The meter should resist corrosion in conditions of the marine environment.
- .11 The meter should be constructed from materials compatible with the liquids to be tested.

#### 2.4.3.4

#### Sampling system

- .1 Sampling points should be so located that relevant samples can be obtained from those outlets that are used for operational discharges in accordance with 2.4.3.2-1. The sampling probes located in the over-board discharge lines and the piping system connecting the sampling probes to the oil content meter should meet the requirements of 2.4.3.4.
- .2 The piping and probes shall be of a material resistant to fire, corrosion and oil, and be of adequate strength, properly jointed and supported.
- .3 The system shall have a stop valve fitted adjacent to each probe, except that, where the probe is mounted in a cargo line, two stop valves shall be fitted in series, in the sample line. One of these may be the remote controlled sample selector valve.
- .4 Sampling probes shall be arranged for easy withdrawal and shall be mounted at an accessible location in a vertical section of the discharge line. Should it be necessary to fit sampling probes in a horizontal section of the discharge line, it shall be ascertained, during the installation survey, that the pipe runs full of liquid at all times during the discharge of the effluent. Sampling probes shall normally penetrate inside the discharge pipe to a distance of  $1/4$  the diameter of that pipe.
- .5 The design of probes and piping shall be such as to minimise their clogging by oil, oily residue and other matter. Means shall be provided for cleaning the probes and piping system by the provision of permanent clean water flushing arrangements or an equivalent method.
- .6 The velocity of the fluid in the piping should be such that, taking into consideration the length of the piping, the overall response time should be as short as possible between an alteration in the mixture being pumped and the alteration in the meter reading and in any case not more than 40 s, including the response time of the meter.
- .7 The location of sampling probes in relation to any point of flow diversion to a slop tank should be selected with regard

to the need for sampling the oily water in the recirculation mode.

- .8 The arrangements for driving the sampling pump or any other pumps used in the system should have regard to the safety requirements of the space in which the pump is located. Any bulkhead penetration between a hazardous and a non-hazardous area should be of a design approved by the *Register*.
- .9 The flushing arrangement shall be such that where necessary it can be utilised for test-running and stabilising the oil content meter and correcting for zero setting.
- .10 Sample water returning to the slop tank shall not be allowed to free-fall into the tank. In tankers equipped with an inert gas system a U - pipe seal of adequate height shall be fitted in the piping leading to a slop tank.
- .11 A valve should be provided for the manual collection of samples from the inlet piping to the meter at a point downstream of any sampling pump or at an equivalent location satisfactory to the *Register*.

#### 2.4.3.5 Flow rate indicating system

- .1 A flow meter for measuring the rate of discharge shall be installed in a vertical section of a discharge line or in any other section of a discharge line as appropriate, so as to be always filled with the liquid being discharged.
- .2 A flow meter should employ an operating principle which is suitable for shipboard use and, where relevant, can be used in large diameter pipes.
- .3 A flow meter should be suitable for the full range of flow rates that may be encountered during normal operation. Alternatively, arrangements such as the use of two flow meters of different ranges or a restriction of the operational flow rate range may be necessary to meet this requirement.
- .4 The flow meter, as installed, shall have an accuracy of  $\pm 10\%$ , or better, of the instantaneous rate of discharge throughout the operating range for discharging the effluent.
- .5 Any component part of the flow meter in contact with the effluent shall be of corrosion-resistant and oil-resistant material of adequate strength.
- .6 The design of the flow metering arrangements shall comply with the safety requirements of the space in which such flow metering arrangements are located.

#### 2.4.3.6 Ship's speed indicating system and ship position indicating device

- .1 The automatic speed signal required for a monitoring system shall be obtained from the ship's speed indicating device by means of a repeater signal. The speed information used may be either speed over the ground or speed through the water, depending upon the speed measuring equipment installed on board.
- .2 The ship position indicating device shall consist of a receiver for a global navigation satellite system or a terrestrial radio navigation system, or other means, suitable for use at all times throughout the intended voyage to establish and update the ship's position by automatic means.

#### 2.4.3.7 Overboard discharge control arrangement

- .1 The overboard discharge control shall be able to stop the discharge of the effluent into the sea automatically by either closing all relevant overboard discharge valves or stopping all relevant pumps. The discharge control arrangement should be fail-safe so that all effluent discharge is stopped when the monitoring system is not in operation, at alarm conditions, or when the monitoring system fails to function.
  - .2 Overboard discharge control arrangement shall activate audio visual alarms and automatically stop the discharge of effluent when:
    - .1 the instantaneous rate of discharge of oil content exceeds 30 liters/per nautical mile;
    - .2 the total quantity of discharged oil exceeds for tankers delivered on or before 31<sup>st</sup> December 1979 1/15000 of the total quantity of the particular cargo of which the residue formed a part, and for tankers delivered after 31<sup>st</sup> December 1979 1/30000 of the total quantity of the particular cargo of which the residue formed a part;
    - .3 monitoring system failure:
      - .1 power failure;
      - .2 loss of sample;
      - .3 significant failure of the measuring or recording system;
      - .4 the input of any sensor exceeds the effective capacity of the system.
- The provisions of this item shall not apply to the discharge of clean or segregated ballast.
- .3 The alarm indicator of the system should be installed in the cargo control room, where provided, and/or in other places where it will attract immediate attention and action.

**2.4.3.8 Processor and transmitting device**

- .1 The processor of a control section should receive signals from the oil content meter, the flow rate indicating system and the ship's speed indicating system at time intervals not exceeding five seconds and should automatically compute the following:
  - .1 instantaneous rate of discharge of oil in litres per nautical mile; and
  - .2 total quantity of oil discharged during the voyage in cubic metres or litres.
- .2 When the limits imposed by 2.4.3.7-2.1 and 2.4.3.7-2.2 are exceeded, the processor should provide alarms and provide command signals to the overboard discharge control arrangement which will cause the discharge of effluent into the sea to stop.
- .3 The processor should normally include a device for the continuous generation of time and date information. Alternative arrangements for the automatic and continuous reception of time and date information from an external source may be accepted.
- .4 In the event of power failure the processor should retain its memory in respect to computation of the total quantity of oil discharged, time and date. A printout of data should be obtained when the monitoring system is operating with manual override, but this is not required if, when the power fails, the monitoring system activates the overboard discharge control to stop the discharge of effluent.

**2.4.3.9 Recording device**

- .1 The recording device of a control section shall include a digital printer, which may be formatted electronically if preferred. The recorded data shall be explicitly identified on the printout. The printout shall be legible and shall remain so once removed from the recording device and shall be retained for at least three years.
- .2 The data to be automatically recorded shall include at least the following:
  - .1 instantaneous rate of discharge of oil [litres per nautical mile];
  - .2 instantaneous oil content, [ppm];
  - .3 total quantity of oil discharged, [m<sup>3</sup>] or [litres];
  - .4 date and time (GMT);
  - .5 ship's speed, [knots];
  - .6 ship's position, latitude and longitude;
  - .7 effluent flow rate, [m<sup>3</sup>/h];
  - .8 status of the overboard discharge control or arrangement;

- .9 oil type selector setting, where applicable;
- .10 alarm condition;
- .11 failure (no flow, fault, etc.); and
- .12 override action (manual override, flushing, calibration, etc.).

Any information inserted manually as a result of an override action should be identified on the printout.

- .3 Data required in 2.4.3.9-2 shall be printed out, as applicable, or may be stored electronically with printout capability, with the following minimum frequency:
  - .1 when the discharge is started;
  - .2 when the discharge is stopped;
  - .3 at intervals of not more than 10 min (except when the system is in stand-by mode);
  - .4 when an alarm condition develops;
  - .5 when normal conditions are restored;
  - .6 whenever the computed instantaneous rate of discharge of oil varies by 10 litres per nautical mile;
  - .7 when zero setting or calibration modes are selected; and
  - .8 on manual command.
- .4 The recording device shall be located in a position easily accessible to the person in charge of the overboard discharge operation.

**2.4.3.10 Data display**

- .1 In addition to the recorded printout, the current data shall be visibly displayed and shall as a minimum contain the following:
  - .1 instantaneous rate of discharge of oil, [litres per nautical mile];
  - .2 total quantity of oil discharged, [m<sup>3</sup>] or [lit];
  - .3 instantaneous oil content, [ppm];
  - .4 flow rate, [m<sup>3</sup>/h];
  - .5 ship's speed, [knots]; and
  - .6 status of the overboard discharge control or arrangement.
- .2 The data display should be located in a position easily observed by the person in charge of the overboard discharge operation.

**2.4.3.11 Manually operated alternatives in the event of equipment malfunction**

The alternative means of obtaining information in the event of a failure in the monitoring system shall be as follows:

- .1 for oil content meter or sampling system: location and measurement of the oil/water interface using the equipment in 2.4.4, visual observation of the surface of the water adjacent to the effluent discharge;
- .2 for flow meter: pump discharge characteristics;

- .3 for ship's speed indicating device: propulsion engine rpm;
- .4 for processor: manual calculation and manual recording; and
- .5 for the overboard discharge control: manual operation of pumps and valves.

#### 2.4.3.12 Installation requirements

- .1 The on-board installation arrangements must be such that satisfactory function of the entire system is obtained and all safety regulations issued by the relevant Administration are complied with.
- .2 The installation arrangements must conform in each case with those specified and approved under the procedure for documentation approval outlined in 2.1.3.4.
- .3 The installation arrangements must also satisfy all relevant parts of 2.4.3 and all relevant installation instructions provided by the manufacturer of the various items of equipment and components.

#### 2.4.4 Oil/water interface detectors

**2.4.4.1** Oil tankers of 150 gross tonnage and above and ships other than oil tankers fitted with cargo spaces which are constructed and utilised to carry oil in bulk of an aggregate capacity of 1000 m<sup>3</sup> and above shall be provided with oil/water interface detectors approved by the *Register* for a rapid and accurate determination of the oil/water interface in slop tanks and shall be available for use in other tanks where the separation of oil and water is effected and from which it is intended to discharge effluent direct to the sea.

**2.4.4.2** Interface detectors may be permanently installed or portable.

**2.4.4.3** Detectors shall be capable of indicating the interface position at any level in the tank.

**2.4.4.4** Detectors need not indicate the interface position continuously.

**2.4.4.5** If permanently installed equipment based on stationary sensors only is provided, the information obtained about the interface should be at least equivalent to that obtainable from portable equipment when used in a normal operating pattern.

**2.4.4.6** The position of permanently installed equipment or the position of the access openings for portable equipment shall be selected with due regard to the internal tank structure and reasonable ship movement.

**2.4.4.7** The control and display unit of a permanently installed system shall be located in the cargo control room or similar space.

**2.4.4.8** Permanently installed equipment inside the tank shall be able to withstand the impact from the jets of tank cleaning equipment.

**2.4.4.9** The equipment may be designed to detect interfaces of liquids having a wide range of density differences.

Detector may be tested for one or several specified applications (e.g. interface between oils and salt water, brackish water or fresh water). The approval document should clearly state the accepted applications and any relevant limitations.

**2.4.4.10** The equipment shall be arranged and used with due regard to relevant operational safety precautions.

**2.4.4.11** The detector and its associated depth measuring equipment shall be practical, reliable and constructed of materials suitable for use in the marine environment and oil.

**2.4.4.12** Detector shall comply with the relevant requirements for use in hazardous areas on oil tankers and shall not interfere with radio communication.

**2.4.4.13** The detector shall respond promptly and in a distinctive manner to changes between oil and water.

**2.4.4.14** The detector shall be capable to indicate the actual position of oil-water interface within limits  $\pm 25$  mm.

**2.4.4.15** The instrument shall be capable of being checked on board for correct working.

**2.4.4.16** Detailed requirements for this equipment are specified in IMO Res. MEPC.5(XIII).

## 2.5 OILY-WATER TRANSFER AND DISCHARGE SYSTEM OF PIPING

### 2.5.1 Oil tanker system of piping

**2.5.1.1** Any oil tanker and ships other than oil tankers provided with cargo spaces intended for carriage of oil having the aggregate capacity of 200 m<sup>3</sup> and above, shall have a discharge manifold for connection to reception facilities for the discharge of dirty ballast water or oil-contaminated water located on the open deck on both sides of the ship.

**2.5.1.2** In every oil tanker of 150 gross tonnage and above, pipelines for the discharge to the sea of ballast water or oil contaminated water from cargo tank areas which may be permitted under 2.4.3 shall be led to the open deck or to the ship's side above the waterline in the deepest ballast condition.

**2.5.1.3** In oil tankers of 150 gross tonnage and above delivered after 31<sup>st</sup> December 1979 means shall be provided for stopping the discharge into the sea of ballast water or oil contaminated water from cargo tank areas, other than those discharges below the waterline permitted under 2.5.1.11, from a position on the upper deck or above located so that the manifold in use referred to in 2.5.1.1 and the discharge to the sea from the pipelines referred to in 2.5.1.2 may be visually observed. Means for stopping the discharge need not be provided at the observation position if a positive communication system such as a telephone or radio system is provided between the observation position and the discharge control position.

**2.5.1.4** Credit for reducing oil outflow in case of bottom damage or side damage may be taken into account

through the use of an installed cargo transfer system having an emergency high suction in each cargo oil tank, capable of transferring from a breached tank or tanks to segregated ballast tanks or to available cargo tankage if it can be assured that such tanks will have sufficient ullage.

**2.5.1.5** Emergency cargo transfer piping, in case of bottom damage or the ship's side damage shall be capable of transferring the oil quantity which corresponds to a half volume of the largest cargo tank involved in two hours of operation according to MARPOL 73/78, Annex I, Regulation 25(5).

**2.5.1.6** Suction piping of the emergency cargo transfer system shall be located at least at the height not less than the vertical extent of the bottom damage ( $v_s$ ) defined in accordance with MARPOL 73/78, Annex I, Regulation 24.

**2.5.1.7** The suction well piping located in double bottom shall be fitted with the stop valves or other closing arrangements located at the point of connection to the tank served, to prevent oil outflow in the event of damage to the piping. Such piping shall be installed as high from the bottom shell as possible.

**2.5.1.8** Cargo transfer system connecting two or more tanks shall be fitted with the stop valves or similar closing devices for separating the tanks from each other.

**2.5.1.9** Lines of piping which run through cargo tanks in a position less than  $t_c$  from the ship's side or less than  $v_c$  from the ship's bottom (see MARPOL 73/78, Annex I, Regulation 24) shall be fitted with valves or similar closing devices at the point at which they open into any cargo tank.

**2.5.1.10** Items 2.5.1.4 to 2.5.1.9 do not apply to oil tankers delivered on or after 1<sup>st</sup> January 2010. The following provisions regarding piping arrangements shall apply to oil tankers delivered on or after 1<sup>st</sup> January 2010:

- .1 The pipelines passing through the cargo tanks at a distance less than  $0,3B_S$  from the ship's side or less than  $0,3D_S$  from the ship's bottom (see MARPOL 73/78, Annex I, Regulation 23(11)) shall be provided with the stop valves or similar closing devices at the point at which they open into any cargo tank.
- .2 Credit for reducing oil outflow through the use of an emergency rapid cargo transfer system or other system arranged to mitigate oil outflow in the event of an accident may be taken into account only after the effectiveness and safety aspects of the system are approved by the Organisation. Submittal for approval shall be made in accordance with the provisions of the Guidelines adopted by resolution MEPC.110(49).
- .3 Every oil tanker of 150 gross tonnage and above which has installed a sea chest that is permanently connected to the cargo pipeline system, shall be equipped with both a sea chest valve and an inboard isolation valve. In addition to these valves, the sea chest shall be capable of isolation from the cargo piping system whilst the tanker is loading, transporting, or dis-

charging cargo by use of a positive means that is to the satisfaction of the *Register*. Such a positive means is a facility that is installed in the pipeline system in order to prevent, under all circumstances, the section of pipeline between the sea chest valve and the inboard valve being filled with cargo.

Positive means may take the form of blanks, spectacle blanks, pipeline blinds, evacuation or vacuum systems, or air or water pressure systems. Evacuation or vacuum systems, or air or water pressure systems are to be equipped with both a pressure gauge and alarm system to enable the continuous monitoring of the status of the pipeline section, and thereby the valve integrity, between the sea chest and inboard valves.

**2.5.1.11** On every oil tanker the discharge of ballast water or oil contaminated water from cargo tank areas shall take place above the waterline, except as follows:

- .1 Segregated ballast and clean ballast may be discharged below the waterline:
  - .1 in ports or at offshore terminals, or
  - .2 at sea by gravity, or
  - .3 at sea by pumps if the ballast water exchange is performed under the provisions of regulation D-1.1 of the *International Convention for the Control and Management of Ships' Ballast Water and Sediments*; provided that the surface of the ballast water has been examined either visually or by other means immediately before the discharge to ensure that no contamination with oil has taken place.
- .2 Oil tankers delivered on or before 31<sup>st</sup> December 1979 which, without modification, are not capable of discharging segregated ballast above the waterline may discharge segregated ballast below the waterline at sea, provided that the surface of the ballast water has been examined immediately before the discharge to ensure that no contamination with oil has taken place.
- .3 Oil tankers delivered on or before 1<sup>st</sup> June 1982 operating with dedicated clean ballast tanks, which without modification are not capable of discharging ballast water from dedicated clean ballast tanks above the waterline, may discharge this ballast below the waterline provided that the discharge of the ballast water is supervised in accordance with 2.2.2.8-3.
- .4 On every oil tanker at sea, dirty ballast water or oil contaminated water from tanks in the cargo area, other than slop tanks, may be discharged by gravity below the waterline, provided that sufficient time has elapsed in order to allow oil/water separation to have taken place and the ballast water has been examined

immediately before the discharge with an oil/water interface detector referred to in 2.4.4, in order to ensure that the height of the interface is such that the discharge does not involve any increased risk of harm to the marine environment.

- .5 On oil tankers delivered on or before 31<sup>st</sup> December 1979, at sea dirty ballast water or oil contaminated water from cargo tank areas may be discharged below the waterline, subsequent to or in lieu of the discharge by the method referred to in 2.5.1.11-4, provided that:
  - .1 a part of the flow of such water is led through permanent piping to a readily accessible location on the upper deck or above where it may be visually observed during the discharge operation; and
  - .2 such part flow arrangements comply with the requirements established by the Administration, which shall contain at least all the provisions of the *Specifications for the Design, Installation and Operation of a Part Flow System for Control of Overboard Discharges* adopted by the Organisation.

**2.5.1.12** Systems shall comply with the requirements of the *Rules for the classification of ships, Part 8 - Piping*.

## 2.5.2 Other ships system of piping

**2.5.2.1** Every ship of 400 gross tonnage and above shall be provided with the transfer piping for oily bilge water from the machinery spaces and oil residues into shore reception facilities. The pipeline shall be led on the ship's both sides. In smaller ships, if agreed with the *Register*, such piping may be led to one side only. The pipeline shall end with the standard flange (see Fig. 2.5.2.1) where a hose can be easily connected to it. A name plate shall be fitted close to the flange. The flange shall be closed by a valve or a blank flange.

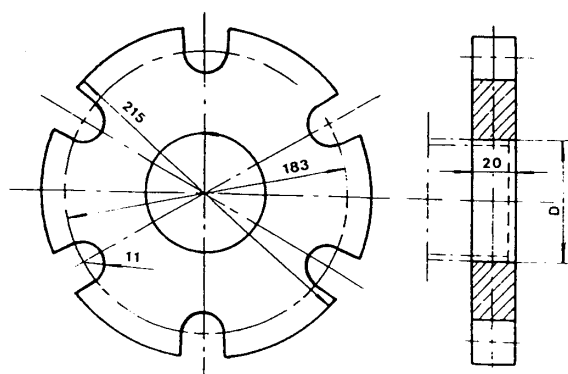

**Figure 2.5.2.1**  
Standard flange of discharge connection

The flange is designed to accept pipes up to a maximum internal diameter of 125 mm and shall be of steel

or other equivalent material having a flat face. This flange, together with a gasket of oil-proof material, shall be suitable for a service pressure of 0.6 MPa. Fastening bolts to be M20.

**2.5.2.2** In the place of the standard flange connection, drip trays or similar devices shall be provided with the drainage piping in accordance with the requirements of the *Rules for the classification of ships, Part 8 - Piping*, Chapter 8.5.

**2.5.2.3** All ships with an aggregate oil fuel capacity of 600 m<sup>3</sup> and above which are delivered on or after 1<sup>st</sup> August 2010, are to comply with the following provisions:

- .1 Lines of oil fuel piping located at a distance from the ship's bottom of less than h or from the ship's side less than w (see MARPOL 73/78, Annex I, Regulation 12A) shall be fitted with valves or similar closing devices within or immediately adjacent to the oil fuel tank.  
These valves shall be capable of being brought into operation from a readily accessible enclosed space the location of which is accessible from the navigation bridge or propulsion machinery control position without traversing exposed freeboard or superstructure decks. The valves shall close in case of remote control system failure (fail in a closed position) and shall be kept closed at sea at any time when the tank contains oil fuel except that they may be opened during oil fuel transfer operations.
- .2 Suction wells in oil fuel tanks may protrude into the double bottom below the boundary line defined by the distance h provided that such wells are as small as practicable and the distance between the well bottom and the bottom shell plating is not less than 0,5 h.

## 2.6 TANKS FOR OIL RESIDUES (SLUDGE) AND OILY-WATER (BILGE) OF A MACHINERY SPACE

### 2.6.1 Definitions

**2.6.1.1 Oil residue (sludge)** – residual waste oil products such as those resulting from the purification of fuel or lubricating oil from main or auxiliary machinery or separated waste oil from bilge water separators, oil filtering equipment or oil collected in drip trays, and waste hydraulic and lubricating oils.

**2.6.1.2 Oil residue (sludge) tanks** – tanks which hold oil residue (sludge) directly from which oil residue (sludge) may be disposed through the standard discharge connection or any other approved means of disposal.

**2.6.1.3 Oily bilge water** – leaked water and oil from the equipment and piping or maintenance works in machinery space of ships, collected on the tank top or bilge wells.

**2.6.1.4 Oily bilge water holding tanks** – tanks collecting oily bilge water prior to its discharge overboard through

15 ppm bilge separator, transfer or disposal into reception facilities.

**2.6.1.5 Oil residue (sludge) incineration systems** – systems providing incineration of oil residue (sludge) generated on board seagoing ships. Oil residue (sludge) incineration systems could be:

- .1 main and auxiliary steam boilers with appropriate oil residue (sludge) processing systems;
- .2 heaters of thermal fluid systems with appropriate oil residue (sludge) processing systems;
- .3 incinerators with appropriate oil residue (sludge) processing systems; or
- .4 inert gas systems with appropriate oil residue (sludge) processing systems.

The oil sludge processing system consists of:

- a) oil residue (sludge) service tank;
- b) oil residue (sludge) preheating system;
- c) filter; and
- d) homogenization system.

**2.6.1.6 Oil residue (sludge) drain tanks** –

- .1 tanks intended to receive separated sludge from purifiers and other oil residue (sludge) drains;
- .2 tanks with suction connection for a sludge collecting pump only capable of discharging to the oil residue (sludge) tanks, without any means for disposal of sludge and drains through the standard discharge connection or in oil residue incineration system.

**2.6.1.7 Sludge collecting pumps** – pumps capable of taking suction from any oil residue (sludge) producing equipment or tank, other than an oil residue (sludge) tank, and discharging only to oil residue (sludge) tanks.

**2.6.1.8 Oil residue (sludge) service tank** – tank for disposal of the oil residue (sludge) in the oil residue (sludge) incineration system.

## 2.6.2 General

**2.6.2.1** Every ship of gross tonnage 400 tons and above shall be provided with a tank or tanks of adequate capacity, having regard to the type of machinery and length of voyage, to receive the oil residues (sludge) which cannot be dealt with otherwise in accordance with the requirements of this Chapter, such as those resulting from the purification of fuel and lubricating oils and oil leakage in the machinery spaces.

**2.6.2.2** In ships delivered after 31<sup>st</sup> December 1979, such tanks shall be designed and constructed so as to facilitate their cleaning and the discharge of residues to reception facilities (see 2.6.5.2). Ships delivered on or before 31<sup>st</sup> December 1979 shall comply with this requirement as far as is reasonable and practicable.

**2.6.2.3** Piping to and from sludge tanks shall have no direct connection overboard, other than the standard discharge connection referred to in 2.5. Ships having this piping

to overboard discharge outlets may comply with this item by the installation of blanks in this piping.

**2.6.2.4** Discharge pipeline from oily residue (sludge) tanks shall not be connected to any system other than oil residue incineration systems, auxiliary boiler suitable for burning oil residues (sludge) or other acceptable means.

**2.6.2.5** For ships less than gross tonnage 400 tons, the *Register* shall specially determine a case for each ship (see 2.6.4).

## 2.6.3 Tanks for oil residues (sludge)

**2.6.3.1** Minimum sludge tank capacity for a ship the keel of which is laid before 31<sup>st</sup> December 1990:

- .1 For ships which do not carry ballast water in oil fuel tanks, should be calculated by the following formula:

$$V_1 = K_1 \cdot C \cdot D \quad [\text{m}^3]$$

where:

$K_1 = 0,01$  for ships where heavy fuel oil is purified for main engine use,  
 $= 0,005$  for ships using diesel oil or heavy fuel oil which does not require purification before use,

$C$  – daily fuel oil consumption [t/day],  
 $D$  – maximum period of voyage between ports where sludge can be discharged ashore [days]. In the absence of precise data a figure of 30 days should be used.

- .2 When such ships are fitted with homogenisers, sludge incinerators or other recognised means on board for the control of sludge, the minimum sludge tank capacity ( $V_1$ ) should, in lieu of the above, be:

$V_1 = 1 \text{ m}^3$  for ships of gross tonnage 400 tons and above but less than gross tonnage 4,000 tons,  
 $= 2 \text{ m}^3$  for ships of gross tonnage 4,000 tons and above.

- .3 For ships which carry ballast water in fuel oil tanks, the minimum sludge tank capacity ( $V_2$ ) should be calculated by the following formula:

$$V_2 = V_1 + K_2 \cdot B \quad [\text{m}^3]$$

where:

$V_1$  – sludge tank capacity specified in 2.6.3.1.1 or 2.6.3.1.2, [ $\text{m}^3$ ],  
 $K_2 = 0,01$  for heavy fuel oil bunker tanks,  
 $= 0,005$  for diesel oil bunker tanks,

$B$  – capacity of water ballast tanks which can also be used to carry oil fuel, [t].

**2.6.3.2** Minimum sludge tank capacity for a ship the keel of which is laid on or after 31<sup>st</sup> December 1990:

- .1 For ships which do not carry ballast water in fuel oil tanks, should be calculated by the following formula:

$$V_1 = K_1 \cdot C \cdot D \text{ [m}^3\text{]}$$

where:

- $K_1 = 0,015$  for ships where heavy fuel oil is purified for main engine use,  
= 0,005 for ships using diesel oil or heavy fuel oil which does not require purification before use,
- $C$  – daily fuel oil consumption, [m<sup>3</sup>/day]
- $D$  – maximum period of voyage between ports where sludge can be discharged ashore [days]. In the absence of precise data a figure of 30 days should be used.

- 2 For ships fitted with homogenisers, sludge incinerators or other recognised means on board for the control of sludge, the minimum sludge tank capacity should be:
  - 1. 50% of the value calculated according to item 2.6.3.2.1; or
  - 2. 1 m<sup>3</sup> for ships of gross tonnage 400 tons and above but less than gross tonnage 4000 tons, or
  - 3. 2 m<sup>3</sup> for ships of gross tonnage 4000 tons and above;
 whichever is the greater.

**2.6.3.3** The separated dirty water and exhausted control water of fuel oil purifiers should be discharged into a particular tank for this purpose, located above the double bottom for the purpose of facilitating its drain without the need of a drain pump. If dirty water and exhausted control water from purifiers is not discharged to a particular tank, in lieu of this it is to be discharged to an oil residue (sludge) drain tank for separated sludge.

**2.6.3.4** Oil residue (sludge) drain tank shall be located below the heavy fuel oil purifier. If this is not possible, the oil residue (sludge) drain tank shall be situated close to the heavy fuel oil purifier in such a way that the discharge line to the tank can be installed at the maximum gradient. The pipelines from the purifier to the tank shall, wherever possible, be straight or fitted with large radius elbows.

## 2.6.4 Tanks for oily bilge water

**2.6.4.1** The *Register* may permit for every ship of gross tonnage 400 tons and above and for every ship of gross tonnage less than 400 tons engaged in international voyages to be provided only with tanks to receive oily bilge water in the machinery spaces, if they are not equipped in accordance with 2.3 or 2.4, under following conditions:

- .1 Holding tank has adequate capacity to retain on board all quantity of bilge water;
- .2 Oily bilge water is retained on board for discharge to reception facilities;
- .3 The Administration has determined that adequate reception facilities are available to receive oily bilge water in sufficient number of ports or terminals the ship calls at;
- .4 International oil pollution prevention certificate, if required, is endorsed in such a way that the ship is engaged exclusively

on the voyages within special areas or in Arctic waters, or the ship is certified under the HSC Code engaged on a scheduled service with a turn around time not exceeding 24 hours and covering also non passenger/cargo carrying relocation voyages for these ships;

- .5 Quantity, time and the port of discharge is recorded in the *Oil Record Book, Part 1*.

**2.6.4.2** Every ship of less than gross tonnage 400 tons engaged in voyage within area of navigation 5-8, shall be provided with tanks for oily bilge water and with the necessary equipment for their discharge (pumps, piping) according to 2.6.4.1 or shall be provided with portable means (vessels, cans) as follows:

- up to 50 gross tonnage ..... 2 vessels of 25 litres
- 50-200 gross tonnage ..... 4 vessels of 25 litres
- 200-400 gross tonnage ..... 6 vessels of 25 litres

The vessels may be of steel or plastic and marked with *bilge* or *oily water* and shall be capable of being filled up by a manual bilge pump.

**2.6.4.3** The discharge piping of the tanks for oily water (bilge) shall not be connected to bilge piping or other piping except to standard flange connection discharge pipeline.

**2.6.4.4** Discharge piping of oily water tanks shall not be led directly to ship's side if the piping is not connected to the pipeline referred to in 2.5.2.

**2.6.4.5** The recommended capacity of oily bilge water holding tanks is shown in Table 2.6.4.5.

**Table 2.6.4.5**  
Recommended capacity of oily bilge water holding tanks

Main engine rating $P$ [kW]	Capacity [m <sup>3</sup> ]
up to 1.000	4
above 1.000 up to 20.000	$P/250$
above 20.000	$40+P/500$

For ships within area of navigation 5-8 minimum oily bilge water tank capacity is to be as follows:

Gross tonnage	Minimum tank capacity
400 GT to 500 GT	250 l
500 GT to 700 GT	500 l
700 GT to 1000 GT	750 l
1000 GT to 1600 GT	1500 l

## 2.6.5 Arrangement of oil residue (sludge) tanks and of oily-water (bilge) tanks

**2.6.5.1** Tanks may be structural or non-structural. Structural tanks shall meet the requirements of the *Rules for the classification of ships, Part 2 - Hull*.



Oily bilge water holding tanks are to be separate and independent from other tanks for the collection of oil residue (sludge).

For ships not equipped with bilge separator or fuel or lubricating oil separators, oily bilge water and oil residue (sludge) may be collected in a common holding tank.

**2.6.5.2** The design and construction of oil residue (sludge) tanks to facilitate their cleaning and the discharge of residues to reception facilities, on ships the keel of which is laid or which are at a similar stage of construction on or after 31<sup>st</sup> December 1990, is to comply with the following:

- .1 sufficient manholes should be provided such that, taking into consideration the internal structure of the sludge tanks, all parts of the tank can be reached to facilitate cleaning. The oil residue (sludge) tanks should be fitted with steaming-out lines for cleaning;
- .2 sludge tanks in ships operating with heavy oil, that needs to be purified for use, should be fitted with adequate sludge heating arrangements up to 60°C or other suitable means to facilitate the pumpability and discharge of the tank content. The suction line from the sludge tanks to the pump shall be provided, where necessary, with heat tracing. Oily bilge water tanks in ships operating with heavy oil should be fitted, where necessary, with heating arrangements to preheat the oily water before discharge;
- .3 oil residue (sludge) tanks shall have no discharge connections to the bilge system, oily bilge water holding tanks, tank top or oily water separators;
- .4 there shall be no interconnections between the oil residue (sludge) tank discharge piping and bilge-water piping other than possible common piping leading to the standard discharge connection referred to in 2.5.2. The connection of both systems to the common piping shall not allow for the transfer of sludge to the bilge system. A screw-down non-return valve arranged in lines connecting to common piping provides an acceptable means to prevent sludge from being transferred to the bilge system. However, arrangements may be made for draining of settled water from the oil residue (sludge) tanks by means of manually operated self-closing valves and arrangements for subsequent visual monitoring of the settled water, or equivalent arrangements. Drain is to lead to an oily bilge water holding tank or to a bilge well;
- .5 the oil residue (sludge) tank and the oily-water (bilge) tank shall be provided with a designated pump for the discharge of the tank content to reception facilities or to any other approved means of disposal of sludge. The pump should be of a suitable type, capacity and discharge head, having regard to the characteristics of the

liquid being pumped and the size and position of tank(s) and the overall discharge time (4 to 8 hours), with suitable means for protection against dry running.

- .6 tanks shall be provided with air pipe.
- .7 tanks shall be provided with visual and audio alarm for high level in the tank.

Ships constructed before 1<sup>st</sup> January 2017 shall comply with 2.6.5.2.3 and 2.6.5.2.4 not later than the first renewal survey carried out on or after 1<sup>st</sup> January 2017.

**2.6.5.3** Inside surface of bottom and walls shall be smooth and the tank bottom shall incline towards the suction pipe.

The openings shall be placed as wide as possible in the frames above the tank bottom in such a way that the oil sludge has free access to the suction line.

**2.6.5.4** The oil residue (sludge) service tank should be equipped with suitable means for drainage of water in accordance with 2.6.5.2.4 and a fuel oil supply connection with a view to improving combustibility and calorific value. Water in oil residues (sludge) may be evaporated by heating the sludge in service tank.

**2.6.5.5** The homogenization system shall assure that the entire contents of the oil residue (sludge) service tank shall be processed into a homogenous and combustible mixture. A device for continuous indication and monitoring of the water content of the oil sludge should be provided.

**2.6.5.6** Where oil residue (sludge) service tank is equipped with suitable means for drainage, the requirements in 2.6.5.2.5 need not be applied.

## 2.7 SPECIAL REQUIREMENTS FOR FIXED OR FLOATING PLATFORMS

**2.7.1** Fixed or floating platforms when engaged in the exploration, exploitation and associated offshore processing of sea-bed mineral resources and other platforms shall comply with the requirements of this *Rules* applicable to ships of 400 gross tonnage and above other than oil tankers.

**2.7.2** Fixed or floating platforms shall be equipped as far as practicable with the installations required in 2.3, 2.4 and 2.6, and shall keep a record of all operations involving oil or oily mixture discharges in a form approved by the *Register*.

**2.7.3** Only the discharges of machinery space drainage and contaminated ballast are subject to MARPOL 73/78. Offshore processing drainage and production water discharge are subject to national regulations.

**2.7.4** In verifying compliance with this Rules in relation to floating production, storage and offloading facilities (FPSO) and floating storage units (FSU), account should be taken of the Guidelines for the application of MARPOL Annex I requirements to FPSO and FSU, according to IMO Res. MEPC.139(53), as amended by IMO Res. MEPC.142(54).

## 2.8 SHIPBOARD OIL POLLUTION EMERGENCY PLAN

**2.8.1** Every oil tanker of 150 tons gross tonnage and above and every ship other than an oil tanker of 400 tons gross tonnage and above shall carry on board a *Shipboard oil pollution emergency plan* approved by the Register.

**2.8.2** Such a plan shall be in accordance with guidelines developed by the Organisation\* and written in the working language of the master and officers. The plan shall consist at least of:

- .1 the procedure to be followed by the master or other persons having charge of the ship to report an oil pollution incident, as required in article 8 and Protocol I of the Convention MARPOL 73/78, based on the guidelines developed by the Organisation\*\*;
- .2 the list of authorities or persons to be contacted in the event of an oil pollution incident;
- .3 a detailed description of the action to be taken immediately by persons on board to reduce or control the discharge of oil following the incident; and
- .4 the procedures and point of contact on the ship for co-ordinating shipboard action with national and local authorities in combating the pollution.

**2.8.3** All oil tankers of 5,000 tons dead-weight or more shall have prompt access to the computerised, shore-based damage stability and residual structural strength calculation programs.

**2.8.4** Any fixed or floating platform or other offshore installation when engaged in the exploration, exploitation and associated offshore processing of sea-bed mineral resources, which has an oil pollution emergency plan coordinated with and approved in accordance with procedures established by the coastal State, should be regarded as complying with 2.8.1 and 2.8.2.

\* Reference is made to *Guidelines for the development of shipboard oil pollution emergency plans* adopted by the Organisation by IMO Res. MEPC.54(32) and IMO Res. MEPC.86(44).

\*\* Reference is made to *General Principles for Ship Reporting Systems and Ship Reporting Requirements, including Guidelines for Reporting Incidents Involving Dangerous Goods, Harmful Substances and/or Marine Pollutants* adopted by the Organisation by resolution A.851(20), as amended by IMO Res. MEPC.138(53).

## 2.9 STS OPERATIONS PLAN

**2.9.1** Any oil tanker of 150 gross tonnage and above involved in transfer of oil cargo between oil tankers at sea (STS operations) shall carry onboard a Plan prescribing how to conduct STS operations (STS operations plan) not later than the date of the first annual, intermediate or renewal survey of the ship to be carried out on or after 1 January 2011.

The STS operations plan shall be written in the working language of the ship and shall be approved by the Register.

**2.9.2** STS operations plan shall be developed taking into account the information contained in IMO Manual on oil pollution, Section I, Prevention, as amended and in ICS/OCIMF Ship to ship transfer guide, Petroleum, last edition.

**2.9.3** The person in overall advisory control of STS operations shall be qualified to perform all relevant duties.

**2.9.4** Records of STS operations in the Oil record book shall be retained onboard for three years and be readily available for inspection by a Party to the Convention.

**2.9.5** Item 2.9 shall not apply to oil transfer operations associated with fixed or floating platforms (see item 2.7).

Item 2.9 shall not apply to bunkering operations and to STS operations necessary for the purpose of securing the safety of a ship or for combating pollution incidents.

### 3 PREVENTION OF POLLUTION BY NOXIOUS LIQUID SUBSTANCES IN BULK

#### 3.1 GENERAL

##### 3.1.1 Application

**3.1.1.1** The present part of the Rules apply to the construction, equipment, installation and systems of the ships, intended to prevent pollution by noxious liquid substances.

MARPOL 73/78, Annex II, entered into force on 2nd October 1983.

**3.1.1.2** Unless expressly provided otherwise, the requirements of this chapter apply to all ships which are intended to carry noxious liquid substances in bulk.

**3.1.1.3** Where a cargo subject to the provisions of Annex I of MARPOL 73/78 is carried in a cargo space of an NLS tanker, the appropriate requirements of chapter 2 shall also apply.

**3.1.1.4** The building in of the equipment, installations, materials and instruments other than those required in this Chapter of the *Rules* shall be permitted only if agreed with the *Register*.

**3.1.1.5** The *Register* may exempt ships from the carriage requirements in 3.2.1 for ships certified to carry individually identified vegetable oils in chapter 17 of the IBC Code, provided the ship complies with the following conditions:

- .1 NLS tanker shall meet all requirements for ship type 3 as identified in the IBC Code except for cargo tank location;
- .2 cargo tanks shall be located at the following distances inboard. The entire cargo tank length shall be protected by ballast tanks or spaces other than tanks that carry oil as follows:
  - .1 wing tanks or spaces shall be arranged such that cargo tanks are located inboard of the moulded line of the side shell plating nowhere less than 760 mm;
  - .2 double bottom tanks or spaces shall be arranged such that the distance between the bottom of the cargo tanks and the moulded line of the bottom shell plating measured at right angles to the bottom shell plating is not less than  $B/15$  (m) or 2,0 m at the centreline, whichever is the lesser.  
The minimum distance shall be 1,0 meter; and
  - .3 the relevant certificate shall indicate the exemption granted.

**3.1.1.6** The provisions of 3.3.4.2 need not apply to a ship constructed before 1<sup>st</sup> July 1986 which is engaged in restricted voyages as determined by the Administration be-

tween ports or terminals within a State Party /of States Parties to the present Convention if:

- .1 each time a tank containing Category X, Y or Z substances or mixtures is to be washed or ballasted, the tank is washed in accordance with a pre-wash procedure approved by the *Register* in compliance with 3.3.2, and the tank washings are discharged to a reception facility;
- .2 subsequent washings or ballast water are discharged to a reception facility or at sea in accordance with other provisions of this Chapter;
- .3 the adequacy of the reception facilities at the ports or terminals referred to above, for the purpose of this paragraph, is approved by the Governments of the States Parties to the present Convention within which such ports or terminals are situated; and
- .4 the certificate required under this Chapter is endorsed to the effect that the ship is solely engaged in such restricted voyages.

**3.1.1.7** For a ship whose constructional and operational features are such that ballasting of cargo tanks is not required and cargo tank washing is only required for repair or dry-docking, the Administration may allow exemption from the provisions of 3.2.2, 3.3.4, 3.3.6 and 3.3.7, provided that all of the following conditions are complied with:

- .1 the design, construction and equipment of the ship are approved by the *Register*, having regard to the service for which it is intended;
- .2 any effluent from tank washings which may be carried out before a repair or dry-docking is discharged to a reception facility, the adequacy of which is ascertained by the Administration;
- .3 the certificate required under this Chapter indicates:
  - .1 that each cargo tank is certified for the carriage of a restricted number of substances which are comparable and can be carried alternately in the same tank without intermediate cleaning; and
  - .2 the particulars of the exemption;
- .4 the ship carries a Manual approved by the *Register*.

**3.1.1.8** The construction and equipment of liquefied gas carriers certified to carry Noxious Liquid Substances listed in the applicable Gas Carrier Code, shall be deemed to be equivalent to the construction and equipment requirements contained in 3.2, 3.3.4, 3.3.6 and 3.3.7, provided that the gas carrier meets all following conditions:

- .1 hold a Certificate of Fitness in accordance with the appropriate Gas Carrier Code for ships certified to carry liquefied gases in bulk;
- .2 hold an International Pollution Prevention Certificate for the Carriage of Noxious Liquid Substances in Bulk, in which it is certified that the gas carrier may carry on-

- ly those Noxious Liquid Substances identified and listed in the appropriate Gas Carrier Code;
- .3 be provided with segregated ballast arrangements;
  - .4 be provided with pumping and piping arrangements, which, to the satisfaction of the *Register*, ensure that the quantity of cargo residue remaining in the tank and its associated piping after unloading does not exceed the applicable quantity of residue as required by 3.3.4.2, 3.3.4.3 or 3.3.4.4; and
  - .5 be provided with a Manual, approved by the *Register*, ensuring that no operational mixing of cargo residues and water will occur and that no cargo residues will remain in the tank after applying the ventilation procedures prescribed in the Manual.

### 3.1.2 Definitions

The explanation of terms and expressions, used in all chapters, is specified in Chapter 1 - General. The following terms and expressions are applied in the present Chapter:

**3.1.2.1 Chemical tanker** – means a ship constructed or adapted for the carriage in bulk of any liquid product listed in chapter 17 of the International Bulk Chemical Code.

**3.1.2.2 NLS tanker** – means a ship constructed or adapted to carry a cargo of Noxious Liquid Substances in bulk and includes an oil tanker as defined in 2.1.2.5 when certified to carry a cargo or part cargo of Noxious Liquid Substances in bulk.

**3.1.2.3 Ship constructed** – means a ship the keel of which is laid or which is at a similar stage of construction. A ship converted to a chemical tanker, irrespective of the date of construction, shall be treated as a chemical tanker constructed on the date on which such conversion commenced. This conversion provision shall not apply to the modification of a ship which complies with all of the following conditions:

- .1 the ship is constructed before 1st July 1986; and
- .2 the ship is certified under the Bulk Chemical Code to carry only those products identified by the Code as substances with pollution hazards only.

**3.1.2.4 Similar stage of construction** – means the stage at which:

- .1 construction identifiable with a specific ship begins; and
- .2 assembly of that ship has commenced comprising at least 50 tons or one percent of the estimated mass of all structural material, whichever is less.

**3.1.2.5 Associated piping** – means the pipeline from the suction point in a cargo tank to the shore connection used for unloading the cargo and includes all ship's piping, pumps and filters which are in open connection with the cargo unloading line.

**3.1.2.6 Clean ballast** – means ballast carried in a tank which, since it was last used to carry a cargo containing a substance in Category X, Y or Z, has been thoroughly cleaned and the residues resulting therefrom have been discharged and the tank emptied in accordance with the appropriate requirements of this Chapter.

**3.1.2.7 Segregated ballast** – see 2.1.2.21.

**3.1.2.8 Liquid substances** – are those having a vapour pressure not exceeding 0,28 MPa absolute at a temperature of 37,8°C.

**3.1.2.9 Noxious liquid substance** - means any substance indicated in the pollution category column of chapter 17 or 18 in IBC Code or in the *Rules for the classification of ships, Part 27 - Chemical Tankers*, Table 17.1.1-1 or 18.1.1-1, or provisionally assessed under the provisions of 3.1.2.9.5 as falling into Category X, Y or Z.

- .1 **Category X** – Noxious liquid substances which, if discharged into the sea from tank cleaning or de-ballasting operations, would present a major hazard to either marine resources or human health and, therefore, justify the prohibition of the discharge into the marine environment.
- .2 **Category Y** – Noxious liquid substances which, if discharged into the sea from tank cleaning or de-ballasting operations, would present a hazard to either marine resources or human health or cause harm to amenities or other legitimate uses of the sea and, therefore, justify the limitation on the quality and quantity of the discharge into the marine environment.
- .3 **Category Z** – Noxious liquid substances which, if discharged into the sea from tank cleaning or de-ballasting operations, would present a minor hazard to either marine resources or human health and, therefore, justify less stringent restrictions on the quality and quantity of the discharge into the marine environment.
- .4 **Other Substances** – substances indicated as OS (Other Substances) in the pollution category column of chapter 18 of the International Bulk Chemical Code which have been evaluated and found to fall outside Category X, Y or Z because they are, at present, considered to present no harm to marine resources, human health, amenities or other legitimate uses of the sea when discharged into the sea from tank cleaning or de-ballasting operations. The discharge of bilge or ballast water or other residues or mixtures containing only substances referred to as Other Substances shall not be subject to any requirements of this Chapter.
- .5 Where it is proposed to carry a liquid substance in bulk which has not been categorised, the Governments of Parties to the Convention involved in the proposed operation shall establish and agree on a provisional assessment for the proposed operation on the basis of the guidelines

for the categorisation of noxious liquid substances, MEPC/ Circ.265 as amended. Until full agreement among the Governments involved has been reached, the substance shall not be carried.

**3.1.2.10 Solidifying substance** – means a noxious liquid substance which:

- .1 in the case of a substance with melting point of less than 15°C which is at a temperature, at the time of unloading, of less than 5°C above its melting point; or
- .2 in the case of a substance with melting point of equal to or greater than 15°C which is at a temperature, at the time of unloading, of less than 10°C above its melting point.

**3.1.2.11 Non-solidifying substance** – means a noxious liquid substance which is not a solidifying substance.

**3.1.2.12 High-viscosity substance** – means a noxious liquid substance in Category X or Y with a viscosity equal to or greater than 50 mPa.s at the unloading temperature.

**3.1.2.13 Low-viscosity substance** – means a noxious liquid substance which is not a high-viscosity substance.

**3.1.2.14 Residue** – means any noxious liquid substance which remains for disposal.

**3.1.2.15 Residue/water mixture** – means residue to which water has been added for any purpose (e.g. tank cleaning, ballasting, bilge slops).

**3.1.2.16 ppm** – means ml/m<sup>3</sup>.

**3.1.2.17 IBC CODE (International Bulk Chemical Code)** – means the International Code for the Construction and Equipment of Ships Carrying Dangerous Chemicals in Bulk.

**3.1.2.18 BCH CODE (Bulk Chemical Code)** – means the Code for the Construction and Equipment of Ships Carrying Dangerous Chemicals in Bulk.

**3.1.2.19 Manual** – means Procedures and Arrangements Manual in accordance with 3.1.6.

**3.1.2.20 Depth of water** – means the charted depth.

**3.1.2.21 En route** – means that the ship is under way at sea on a course or courses, including deviation from the shortest direct route, which as far as practicable for navigational purposes, will cause any discharge to be spread over as great an area of the sea as is reasonable and practicable.

**3.1.2.22 Nearest land** – see 2.1.2.33.

### 3.1.3 Scope of supervision

**3.1.3.1 Intentionally blank.**

**3.1.3.2** Supervision during construction shall cover:

- .1 Ventilation system
- .2 Tank washing system
- .3 Residue discharge system

**3.1.3.3** Technical documentation which shall be submitted to the *Register* for approval for the systems referred to in 3.1.3.2:

- .1 Technical description, method of work with technical data and instruction for operation and maintenance;
- .2 General plan with cross sections;
- .3 List of materials and component parts;
- .4 General and functional scheme, as appropriate;
- .5 Scheme of the control, signalling and protection, as appropriate;
- .6 Electrical scheme, as appropriate;
- .7 Drawings of assemblies and component parts of the system, as appropriate;
- .8 Testing program.

If found necessary, the *Register* may require additional technical documentation, data on safety of the equipment and arrangements (installations) as well as the documentation in accordance with the *Rules for the classification of ships, Part 27 - Chemical tankers*.

### 3.1.4 Workshop testing

**3.1.4.1** Equipment, installations, systems and instruments after being assembled shall be tested according to the program referred to in 3.1.3.3-8 approved by the *Register*.

In particular cases, the *Register* may permit the testing to be carried out onboard ship instead of testing on test bench.

### 3.1.5 General requirements

**3.1.5.1** Materials intended for the manufacture of equipment, installations and systems shall comply with the requirements of the *Rules for the classification of ships, Part 25 - Metallic materials*.

**3.1.5.2** Electrical equipment of the machines and the equipment shall meet the requirements of the *Rules for the classification of ships, Part 12 - Electrical equipment*.

**3.1.5.3** Pipeline systems, pipes and fittings shall meet the requirements of the *Rules for the classification of ships, Part 8 - Piping*.

### 3.1.6 Procedures and Arrangements Manual

**3.1.6.1** Every ship certified to carry substances of Category X, Y or Z shall have on board a Manual approved by the *Register*. The Manual shall have a standard format in compliance with appendix 4 to MARPOL 73/78, Annex II. In the case of a ship engaged in international voyages on which the language used is not English, French or Spanish, the text shall include a translation into one of these languages.

**3.1.6.2** The main purpose of the Manual is to identify for the ship's officers the physical arrangements and all the operational procedures with respect to cargo handling, tank cleaning, slops handling and cargo tank ballasting and de-ballasting which must be followed in order to comply with the requirements of MARPOL 73/78, Annex II.

## 3.2 CHEMICAL TANKER CONSTRUCTION

### 3.2.1 General requirements

**3.2.1.1** Chemical tankers shall be constructed in a compliance with the requirements of the *Rules for the classification of ships, Part 27 - Chemical tankers*.

**3.2.1.2** The design, construction, equipment and operation of ships carrying noxious liquid substances, identified in chapter 17 of IBC Code, in bulk, shall be in compliance with the following provisions, to minimise the uncontrolled discharge into the sea of such substances:

- .1 the International Bulk Chemical Code when the chemical tanker is constructed on or after 1<sup>st</sup> July 1986; or
- .2 the Bulk Chemical Code as referred to in paragraph 1.7.2 of that Code for:
  - .1 ships for which the building contract is placed on or after 2<sup>nd</sup> November 1973 but constructed before 1<sup>st</sup> July 1986, and which are engaged on voyages to ports or terminals under the jurisdiction of other States Parties to the Convention; and
  - .2 ships constructed on or after 1<sup>st</sup> July 1983 but before 1<sup>st</sup> July 1986, which are engaged solely on voyages between ports or terminals within the State the flag of which the ship is entitled to fly.
- .3 the Bulk Chemical Code as referred to in paragraph 1.7.3 of that Code for:
  - .1 ships for which the building contract is placed before 2<sup>nd</sup> November 1973 and which are engaged on voyages to ports or terminals under the jurisdiction of other States Parties to the Convention; and
  - .2 ships constructed before 1<sup>st</sup> July 1983, which are solely engaged on voyages between ports or terminals within the State the flag of which the ship is entitled to fly.

**3.2.1.3** In respect of ships other than chemical tankers or liquefied gas carriers certified to carry Noxious Liquid Substances in bulk identified in chapter 17 of the International Bulk Chemical Code, the Administration shall establish appropriate measures based on the Guidelines developed by the Organisation (reference is made to resolution A.673(16), as amended by IMO Res. MEPC.158(55) and IMO Res. MEPC.148(54)) in order to ensure that the provisions shall be such as to minimise the uncontrolled discharge into the sea of such substances.

### 3.2.2 Slop tanks

**3.2.2.1** Slop tanks may be needed for certain washing procedures. Slop tanks shall meet the following requirements:

- .1 Minimum capacity of slop tanks shall be specified with respect to navigational

conditions of a tanker. Cargo tanks may be used as slop tanks.

- .2 The number of slop tanks shall be determined with respect to the liability of decomposition of the different cargo residues which are carried simultaneously.
- .3 Pumps, piping and ventilation serving slop tanks shall be separated from similar arrangements which are used for tanks with cargo which may be hazardous in contact with water.

## 3.3 EQUIPMENT FOR PREVENTION OF POLLUTION

### 3.3.1 Equipment of ventilation system

**3.3.1.1** The ventilation system shall comply with the requirements of *Rules for the classification of ships, Part 27 - Chemical tankers*, Chapter 6.

**3.3.1.2** Cargo residues of substances with a vapour pressure greater than 5000 Pa at 20°C may be removed from a cargo tank by ventilation.

**3.3.1.3** The pipelines shall be drained and further cleared of liquid by means of ventilation equipment.

**3.3.1.4** The list and trim shall be adjusted to the minimum levels possible so that evaporation of residues in the tank is enhanced.

**3.3.1.5** Ventilation equipment producing an air jet which can reach the tank bottom shall be used. Figure 3.3.1.5 could be used to evaluate the adequacy of ventilation equipment used for ventilating a tank of a given depth.

**3.3.1.6** Ventilation equipment shall be placed in the tank opening closest to the tank sump or suction point.

**3.3.1.7** Ventilation equipment shall, when practicable, be positioned so that the air jet is directed at the tank sump or suction point and impingement of the air jet on tank structural members is to be avoided as much as possible.

**3.3.1.8** Ventilation shall continue until no visible remains of liquid can be observed in the tank. This shall be verified by a visual examination or an equivalent method.

### 3.3.2 Equipment of cargo tank washing system (for ships built on or after 1<sup>st</sup> July 1994)

**3.3.2.1** For ship built before 1<sup>st</sup> July 1994, see MARPOL 73/78, Annex II, Appendix 6, Chapter A.

**3.3.2.2** The equipment of cargo tank washing system shall comply with the requirements of MARPOL 73/78, Annex II and can be designed and installed as the oil tanker washing equipment according to 2.2.1, with difference in a material and a procedure.

**3.3.2.3** The equipment and procedures include pre-wash and wash of cargo tanks and slop tanks, for non-solidifying and solidifying noxious substances.

**3.3.2.4** Non-solidifying noxious substances washing equipment without recycling:

- .1 Tanks should be washed by means of a rotary water jet, operated at sufficiently high water pressure. In the case of Category X substances washing machines should be operated in such locations that all tank surfaces are washed. In the case of Category Y substances only one location need be used.
- .2 During washing the amount of liquid in the tank should be minimised by continuously pumping out slops and promoting flow to the suction point. If this condition cannot be met, the washing procedure should be repeated three times, with thorough stripping of the tank between washings.
- .3 Those substances which have a viscosity equal to or greater than 50 mPa.s at 20°C should be washed with hot water (temperature at least 60°C), unless the properties of such substances make the washing less effective.
- .4 The quantities of wash water used shall not be less than those specified in 3.3.2.7-.1 or determined according to 3.3.2.7-.2.
- .5 After pre-washing the tanks and lines shall be thoroughly stripped.

**3.3.2.5** Solidifying noxious substances washing equipment without recycling:

- .1 Tanks should be washed as soon as possible after unloading. If possible, tanks should be heated prior to washing.
- .2 Residues in hatches and manholes should preferably be removed prior to the pre-wash.
- .3 Tanks should be washed by means of a rotary water jet operated at sufficiently high water pressure and in locations to ensure that all tank surfaces are washed.
- .4 During washing the amount of liquid in the tank shall be minimised by pumping out slops continuously and promoting flow to the suction point. If this condition cannot be met, the washing procedure shall be repeated three times with thorough stripping of the tank between washings.
- .5 Tanks shall be washed with hot water (temperature at least 60°C), unless the properties of such substances make the washing less effective.
- .6 The quantities of wash water used shall not be less than those specified in 3.3.2.7-.1 or determined according to 3.3.2.7-.2.
- .7 After pre-washing the tanks and lines shall be thoroughly stripped.

**3.3.2.6** Pre-wash procedures with recycling of washing medium:

- .1 Washing with a recycled washing medium may be adopted for the purpose of washing more than one cargo tank. In de-

termining the quantity, due regard must be given to the expected amount of residues in the tanks and the properties of the washing medium and whether any initial rinse or flushing is employed. Unless sufficient data are provided, the calculated end concentration of cargo residues in the washing medium shall not exceed 5% based on nominal stripping quantities.

- .2 The recycled washing medium shall only be used for washing tanks having contained the same or similar substance.
- .3 A quantity of washing medium sufficient to allow continuous washing shall be added to the tank or tanks to be washed.
- .4 All tank surfaces shall be washed by means of a rotary jet(s) operated at sufficiently high pressure. The recycling of the washing medium may either be within the tank to be washed or via another tank, e.g. a slop tank.
- .5 The washing shall be continued until the accumulated throughput is not less than that corresponding to the relevant quantities given in 3.3.2.7-.1 or determined according to 3.3.2.7-.2.
- .6 Solidifying substances and substances with viscosity equal to or greater than 50 mPa.s at 20°C shall be washed with hot water (temperature at least 60°C) when water is used as the washing medium, unless the properties of such substances make the washing less effective.
- .7 After completing the tank washing with recycling to the extent specified in paragraph 5, the washing medium shall be discharged and the tank thoroughly stripped. Thereafter, the tank shall be subjected to a rinse, using clean washing medium, with continuous drainage and discharged to a reception facility. The rinse shall as a minimum cover the tank bottom and be sufficient to flush the pipelines, pump and filter.

**3.3.2.7** Minimum quantity of water to be used in a pre-wash:

Minimum quantity of water to be used in a pre-wash:

- .1 The minimum quantity of water to be used in a pre-wash is determined by the residual quantity of noxious liquid substance in the tank, the tank size, the cargo properties, the permitted concentration in any subsequent wash water effluent, and the area of operation. The minimum quantity is given by the following formula:

$$Q = k (15r^{0.8} + 5r^{0.7} \cdot V/1000)$$

where:

- $Q$  – the required minimum quantity, [m<sup>3</sup>]  
 $r$  – the residual quantity per tank, [m<sup>3</sup>].

The value of  $r$  shall be the value demonstrated in the actual stripping efficiency test, but shall not be taken lower than 0,100 m<sup>3</sup> for a tank volume of 500 m<sup>3</sup> and above and 0,040 m<sup>3</sup> for a tank volume of 100 m<sup>3</sup> and below. For tank sizes between 100 m<sup>3</sup> and 500 m<sup>3</sup> the minimum value of  $r$  allowed to be used in the calculations is obtained by linear interpolation.

For Category X substances the value of  $r$  shall either be determined based on stripping tests according to the Manual, observing the lower limits as given above, or be taken to be 0.9 m<sup>3</sup>.

- V – tank volume, [m<sup>3</sup>]
- k – a factor having values as follows:
  - Category X, non-Solidifying, Low-Viscosity Substance,  $k = 1.2$
  - Category X, Solidifying or High-Viscosity Substance,  $k = 2.4$
  - Category Y, non-Solidifying, Low-Viscosity Substance,  $k = 0.5$
  - Category Y, Solidifying or High-Viscosity Substance,  $k = 1.0$

- 2 Verification testing for approval of pre-wash volumes lower than those given in paragraph 3.3.2.7-1 may be carried out to the satisfaction of the *Register* to prove that the requirements of MARPOL 73/78, Annex II, Reg.13 are met, taking into account the substances the ship is certified to carry. The pre-wash volume so verified shall be adjusted for other pre-wash conditions by application of the factor  $k$  as defined in paragraph 3.3.2.7-1.

**3.3.2.8** When a washing medium other than water, such as mineral oil or chlorinated solvent, is used instead of water to wash a tank, its discharge shall be governed by the provisions of either MARPOL 73/78, Annex I or MARPOL 73/78, Annex II, which would apply to the medium had it been carried as cargo. Tank washing procedures involving the use of such a medium shall be set out in the Manual and be approved by the *Register*.

**3.3.2.9** When small amounts of cleaning additives (detergent products) are added to water in order to facilitate tank washing, no additives containing Pollution Category X components shall be used except those components that are readily biodegradable and present in a total concentration of less than 10% of the cleaning additive. No restrictions additional to those applicable to the tank due to the previous cargo shall apply.

### **3.3.3 Systems for the discharge of residues of noxious liquid substances**

**3.3.3.1** The discharge into the sea of residues of substances assigned to Category X, Y or Z or of those provisionally assessed as such or ballast water, tank washings or other mixtures containing such substances shall be prohibited unless such discharges are made in full compliance with the applicable operational requirements contained in MARPOL 73/78, Annex II.

**3.3.3.2** Before any pre-wash or discharge procedure is carried out in accordance with this regulation, the relevant tank shall be emptied to the maximum extent in accordance with the procedures prescribed in the Manual.

**3.3.3.3** The carriage of substances which have not been categorised, provisionally assessed or evaluated as referred to in 3.1.2.9 or of ballast water, tank washings or other mixtures containing such residues shall be prohibited along with any consequential discharge of such substances into the sea.

**3.3.3.4** The discharge into the sea of residues of noxious liquid substances is to be made below the waterline through the underwater discharge outlet not exceeding the maximum rate for which the underwater discharge outlet is designed.

**3.3.3.5** Equipment and arrangement of piping for the transfer and the discharge of noxious liquid substance residues shall comply with requirements of *Rules for the classification of ships, Part 8 - Piping* and *Part 27 - Chemical tankers*.

#### **3.3.3.6 Discharge of residues of Category X**

Subject to the provision of 3.3.3.1, 3.3.3.2 and 3.3.3.3, the following provisions shall apply:

- 1 A tank from which a substance in Category X has been unloaded, shall be pre-washed before the ship leaves the port of unloading. The resulting residues shall be discharged to a reception facility until the concentration of the substance in the effluent to such facility, as indicated by analyses of samples of the effluent taken by the surveyor, is at or below 0.1% by weight. When the required concentration level has been achieved, remaining tank washings shall continue to be discharged to the reception facility until the tank is empty. Appropriate entries of these operations shall be made in the Cargo Record Book and endorsed by the surveyor appointed by the Party to the Convention.
- 2 Any water subsequently introduced into the tank may be discharged into the sea in accordance with the discharge standards in MARPOL 73/78, Annex II, Reg.13.2.
- 3 Where the Government of the receiving party is satisfied that it is impracticable to measure the concentration of the substance in the effluent without causing undue delay to the ship, that Party may accept an alternative procedure as being equivalent to obtain the required concentration in 3.3.3.6.1 provided that:
  - 1 the tank is pre-washed in accordance with a procedure approved by the *Register* in compliance with 3.3.2; and
  - 2 appropriate entries shall be made in the Cargo Record Book and endorsed by the surveyor referred to in 3.3.3.6.1.

#### **3.3.3.7 Discharge of residues of Category Y and Z**



Subject to the provision of 3.3.3.1, 3.3.3.2 and 3.3.3.3, the following provisions shall apply:

- .1 With respect to the residue discharge procedures for substances in Category Y or Z the discharge standards in MARPOL 73/78, Annex II, Reg.13.2 shall apply.
- .2 If the unloading of a substance of Category Y or Z is not carried out in accordance with the Manual, a pre-wash shall be carried out before the ship leaves the port of unloading, unless alternative measures are taken to the satisfaction of the surveyor referred to in 3.3.3.6.1 to remove the cargo residues from the ship to quantities specified in MARPOL 73/78, Annex II. The resulting tank washings of the pre-wash shall be discharged to a reception facility.
- .3 For High-Viscosity or Solidifying Substances in Category Y the following shall apply:
  - .1 a pre-wash procedure as specified in 3.3.2 shall be applied;
  - .2 the residue/water mixture generated during the pre-wash shall be discharged to a reception facility until the tank is empty; and
  - .3 any water subsequently introduced into the tank may be discharged into the sea in accordance with the discharge standards in MARPOL 73/78, Annex II, Reg.13.2.

**3.3.3.8** Operational requirements for ballasting and de-ballasting:

- .1 After unloading, and, if required, after a pre-wash, a cargo tank may be ballasted. Procedures for the discharge of such ballast are set out in MARPOL 73/78, Annex II, Reg.13.2.
- .2 Ballast introduced into a cargo tank which has been washed to such an extent that the ballast contains less than 1 ppm of the substance previously carried, may be discharged into the sea without regard to the discharge rate, ship's speed and discharge outlet location, provided that the ship is not less than 12 miles from the nearest land and in water that is not less than 25 metres deep. The required degree of cleanliness has been achieved when a pre-wash as specified in 3.3.2 has been carried out and the tank has been subsequently washed with a complete cycle of the cleaning machine for ships built before 1 July 1994 or with a water quantity not less than that calculated with  $k=1.0$ .
- .3 The discharge into the sea of clean or segregated ballast shall not be subject to the requirements of MARPOL 73/78, Annex II.

### 3.3.4 Cargo systems

**3.3.4.1** Cargo system shall comply with the requirements of the *Rules for the classification of ships, Part 8 - Piping* and *Part 27 - Chemical tankers*.

**3.3.4.2** Every ship constructed before 1<sup>st</sup> July 1986 shall be provided with a pumping and piping arrangement to ensure that each tank certified for the carriage of substances in Category X or Y does not retain a quantity of residue in excess of 300 litres in the tank and its associated piping and that each tank certified for the carriage of substances in Category Z does not retain a quantity of residue in excess of 900 litres in the tank and its associated piping.

A performance test shall be carried out in accordance with 3.3.4.6.

**3.3.4.3** Every ship constructed on or after 1<sup>st</sup> July 1986 but before 1<sup>st</sup> January 2007 shall be provided with a pumping and piping arrangement to ensure that each tank certified for the carriage of substances in Category X or Y does not retain a quantity of residue in excess of 100 litres in the tank and its associated piping and that each tank certified for the carriage of substances in Category Z does not retain a quantity of residue in excess of 300 litres in the tank and its associated piping. A performance test shall be carried out in accordance with 3.3.4.6.

**3.3.4.4** Every ship constructed on or after 1<sup>st</sup> January 2007 shall be provided with a pumping and piping arrangement to ensure that each tank certified for the carriage of substances in Category X, Y or Z does not retain a quantity of residue in excess of 75 litres in the tank and its associated piping. A performance test shall be carried out in accordance with 3.3.4.6.

**3.3.4.5** For a ship other than a chemical tanker constructed before 1<sup>st</sup> January 2007 which cannot meet the requirements for the pumping and piping arrangements for substances in Category Z referred to in 3.3.4.2 and 3.3.4.3 no quantity requirement shall apply. Compliance is deemed to be reached if the tank is emptied to the most practicable extent.

**3.3.4.6** Assessment of residue quantities in cargo tanks, pumps and associated piping:

- .1 The procedure for testing the efficiency of cargo pumping systems by assessment of residue quantities in cargo tanks, pumps and associated piping is to be in accordance with MARPOL 73/78, Annex II, Appendix 5, item 3.
- .2 The cargo pumping systems should be designed to meet the required maximum amount of residue per tank and associated piping as specified in 3.3.4.2, 3.3.4.3 and 3.3.4.4.
- .3 Cargo pumping systems shall be tested with water to prove their performance. Such water tests shall, by measurement, show that the system meets the requirements of 3.3.4.2, 3.3.4.3 and 3.3.4.4. In respect of 3.3.4.2 and 3.3.4.3 a tolerance of 50 litres per tank is acceptable. The quantity measured is termed the *stripping quantity*. The stripping quantity of each

tank shall be recorded in the ship's Manual. Pumping performance test shall be approved by the Register.

- 4 After having determined the stripping quantity of one tank, the Register may use the determined quantities for a similar tank, provided that the pumping system in that tank is similar and operating properly.

### 3.3.5 Cargo pump room

**3.3.5.1** Cargo pump room shall comply with the requirements of the *Rules for the classification of ships, Part 27 - Chemical Tankers, Part 2 - Hull and Part 12 - Electrical installation*.

**3.3.5.2** Control position of bilge piping system of cargo pump room shall be located outside the room.

**3.3.5.3** Bilge piping system of cargo pump room shall provide for the possibility of transferring bilge effluent into a slop tank or cargo tanks.

### 3.3.6 Underwater discharge outlet location

**3.3.6.1** Ships certified to carry substances of category X, Y or Z shall have an underwater discharge outlets.

**3.3.6.2** For ships constructed before 1<sup>st</sup> January 2007 and certified to carry substances of category Z an underwater discharge outlet is not mandatory.

**3.3.6.3** The underwater discharge outlet (or outlets) shall be located within the cargo area in the vicinity of the turn of the bilge and shall be so arranged as to avoid the re-intake of residue/water mixtures by the ship's seawater intakes.

**3.3.6.4** If dual outlets are provided to achieve a higher permissible discharge rate, these should be located on opposite sides of the ship.

### 3.3.7 Underwater discharge outlet size

**3.3.7.1** The underwater discharge outlet arrangement shall be such that the residue/water mixture discharged into the sea will not pass through the ship's boundary layer. To this end, when the discharge is made normal to the ship's shell plating, the minimum diameter of the discharge outlet is governed by the following equation:

$$D = \frac{Q_D}{5L} \quad [\text{m}] \quad (3.3.7.1)$$

where:

- $D$  – minimum diameter of the discharge outlet, [m];
- $L$  – distance from the forward perpendicular to the discharge outlet, [m];
- $Q_D$  – maximum rate selected at which the ship may discharge a residue/water mixture through the outlet, [m<sup>3</sup>/h].

**3.3.7.2** When the discharge is directed at an angle to the ship's shell plating, the relationship (3.3.7.1) shall be

modified by substituting for  $Q_D$  the component of  $Q_D$  which is normal to the ship's shell plating.

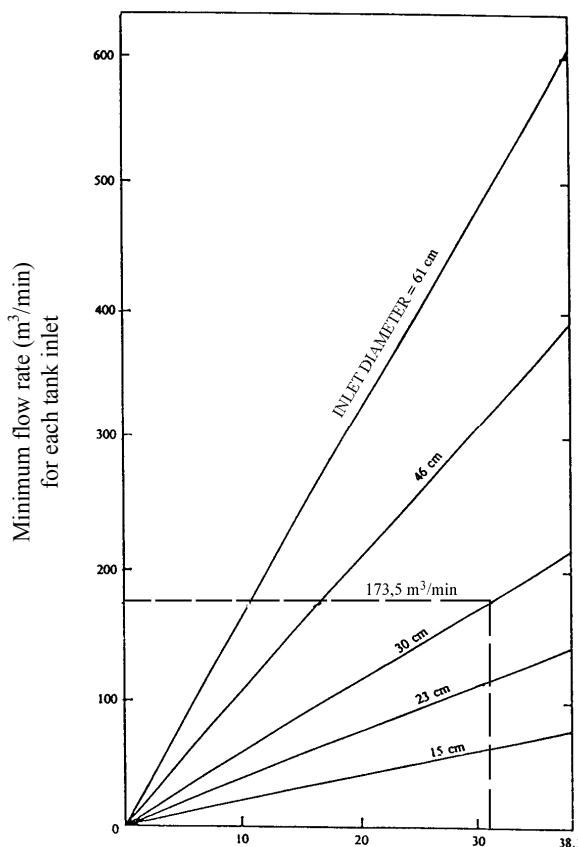

Figure 3.3.1.5  
Inlet jet penetration depth [m]

## 3.4 SHIPBOARD MARINE POLLUTION EMERGENCY PLAN FOR NOXIOUS LIQUID SUBSTANCES

**3.4.1** Every ship of 150 tons gross tonnage and above certified to carry noxious liquid substances in bulk shall carry on board a *Shipboard marine pollution emergency plan for noxious liquid substances* approved by the Register.

**3.4.2** Plan shall be in accordance with Guidelines\* developed by the Organisation and written in a working language of the master and officers. Plan shall consist at least of:

- 1 the procedure to be followed by the master or other persons having charge of the ship to report a noxious liquid substances pollution incident, as required in article 8 and Protocol I of the Convention MARPOL 73/78, based on the Guidelines developed by the Organisation\*\*.
- 2 the list of authorities or persons to be contacted in the event of a noxious liquid substance pollution incident.
- 3 a detailed description of the action to be taken immediately by persons on board to reduce or control the discharge of noxious liquid substances following the incident.

- .4 the procedures and point of contact on the ship for co-ordinating shipboard action with national and local authorities in combating the pollution.

**3.4.3** In the case of ships to which regulation 37 of Annex I of the Convention MARPOL 73/78 also apply, such a plan may be combined with the *Shipboard oil pollution emergency plan*. In this case, the title of a plan shall be *Shipboard marine pollution emergency plan*.

- \* Refer to *Guidelines for the development of shipboard marine pollution emergency plans for oil and/or noxious liquid substances*, according to IMO Res. MEPC.85(44) as amended by IMO Res. MEPC.137(53).
- \*\* Refer to *General principles for ship reporting systems and ship reporting requirements, including Guidelines for reporting incidents involving dangerous goods, harmful substances and /or marine pollutants*, according to resolution A.851(20), as amended by IMO Res. MEPC.138(53).

## 4 PREVENTION OF POLLUTION BY HARMFUL SUBSTANCES CARRIED BY SEA IN PACKAGED FORM

**4.1** This Chapter applies on all ships carrying harmful substances in packaged form. Annex III of MARPOL 73/78 entered into force on 1 July 1992.

Detailed requirements on carriage of harmful substances in packaged form are contained in IMO Res. MEPC.193(61).

**4.2** **Harmful substances** – for the purpose of this Chapter, are those substances which are identified as marine pollutants in the IMDG Code.

**4.3** **Packaged form** – for the purpose of this Chapter, is defined as the form of containment specified for harmful substances in the IMDG Code.

**4.4** Carriage of harmful substances is prohibited, except in accordance with the provisions of this Chapter.

**4.5** The requirements of this Chapter do not apply to ship's store and equipment.

**4.6** Packages shall be adequate to minimise the hazard to the marine environment, having regard to their specific contents.

**4.7** Packages containing a harmful substance shall be durably marked or labelled to indicate that the substance is a harmful substance in accordance with the relevant provisions of the IMDG Code.

The method of affixing marks or labels on packages containing a harmful substance shall be in accordance with the relevant provisions of the IMDG Code.

Transport information relating to the carriage of harmful substances shall be in accordance with the relevant provisions of the IMDG Code.

**4.8** Harmful substances shall be properly stowed and secured so as to minimize the hazards to the marine environment without impairing the safety of the ship and persons on board.

A ship shall carry a detailed stowage plan setting forth the harmful substances on board and the location thereof.

**4.9** Certain harmful substances may need to be prohibited for carriage or be limited as to the quantity which may be carried aboard a ship. In limiting the quantity, due consideration shall be given to size, construction and equipment of the ship, as well as the packaging and the nature of the substances.

**4.10** Jettisoning of harmful substances carried in packaged form shall be prohibited, except where necessary for the purpose of securing the safety of the ship or saving life at sea.

Subject to the provisions of the Convention, appropriate measures based on the physical, chemical and biological properties of harmful substances shall be taken to regulate the washing of leakages overboard.

## 5 PREVENTION OF POLLUTION BY SEWAGE

### 5.1 GENERAL

#### 5.1.1 Application

**5.1.1.1** Annex IV of MARPOL 73/78 entered into force on 27<sup>th</sup> September 2003.

**5.1.1.2** This Chapter of present *Rules* apply to the arrangement and equipment of ships intended for prevention of pollution by sewage.

**5.1.1.3** The provisions of this Chapter shall apply to following ships engaged on international voyages:

- .1 new ships of 400 tons gross tonnage and above;
- .2 new ships of less than 400 tons gross tonnage which are certified to carry more than 15 persons;
- .3 existing ships of 400 gross tonnage and above, five years after the date of entry into force of Annex IV of MARPOL 73/78.
- .4 existing ships of less than 400 gross tonnage which are certified to carry more than 15 persons, five years after the date of entry into force of Annex IV of MARPOL 73/78.

**5.1.1.4** The provisions of this Chapter shall also apply to ships engaged on voyages within area of navigation 5 to 8, in dependence of size and type of ship which is in each particular case subject to consideration and decision by the Administration.

**5.1.1.5** The provisions of 5.2.1.2 apply to new passenger ships on or after 1st June 2019 and to existing passenger ships on or after 1st June 2021.

**5.1.1.6** Guidelines on effluent standards and performance test for sewage treatment plants in Res. MEPC.227(64) shall be applied on or after 1st January 2016. The requirements of these guidelines will apply to sewage treatment plants installed onboard ships the keels of which are laid or which are at a similar stage of construction on or after 1st January 2016. For other ships, the requirements of these guidelines will apply to installations with a contractual delivery date to the ship on or after 1st January 2016, or in the absence of a contractual delivery date, the actual delivery of the equipment to the ship on or after 1st January 2016.

#### 5.1.2 Definitions

The explanation of terms and expressions, used in all chapters, is specified in Chapter 1 - General.

The following terms and expression are applied in the present Chapter:

**5.1.2.1 New ship** – means a ship:

- .1 for which the building contract is placed, or in the absence of a building contract,

the keel of which is laid, or which is at a similar stage of construction, on or after the date of entry into force Annex IV of MARPOL 73/78; or

- .2 the delivery of which is three years of more after the date of entry into force Annex IV of MARPOL 73/78.

**5.1.2.2 Existing ship** – means a ship which is not a new ship.

**5.1.2.3 Sewage (black water)** – means:

- .1 drainage and other wastes from any form of toilets, urinals, and WC scuppers;
- .2 drainage from medical premises (dispensary, sick bay, etc.) via wash basins, wash tubs and scuppers located in such premises;
- .3 drainage from spaces containing living animals; or
- .4 other waste waters when mixed with the drainage defined above.

**5.1.2.4 Sewage (grey water)** – from domestic and accommodation spaces:

- .1 waste waters from basins, shavers, wash tubs and scuppers except waters as specified in 5.1.2.3.
- .2 waste waters from laundries.
- .3 waste waters from food washings, galley's equipment and provision's rooms (stores).

**5.1.2.5 Holding tank** – means a tank used for the collection and storage of sewage.

**5.1.2.6 Sewage treatment plant** – is a plant intended to comminute and disinfect the sewage with:

- .1 a biologically detachment of organic substances
- .2 a disinfection and a sterilisation
- .3 a separation of solid substances and their comminute or removal.

**5.1.2.7 Number of persons** – crew, passengers and special personnel shall be in accordance with the number of places intended for their accommodation in board.

**5.1.2.8 Faecal coliform bacteria** – are bacteria number of which is usually taken for the presence of faecal substances and the micro-organism which might be hazardous to human health.

**5.1.2.9 Biochemical oxygen demand** – BOD is a quantity of oxygen needed in the biochemical oxidation process of the organic substances in the sewage during 5-day testing.

**5.1.2.10 Discharged solid substances** – mean weight of the discharged solid substances found in testing 40 samples of the sewage.

**5.1.2.11 Aerobic process** – a biochemical oxidative process for breaking down the sewage by naturally occurring bacteria, which strips oxygen from the water, producing more water, carbon dioxide and new bacteria.

**5.1.2.12 Sewage gasses** – toxic and flammable gasses, which may occur in sewage system. If insufficient oxygen is present, alternative bacteria become dominant and the pro-

cess becomes anaerobic with the production of gasses, including hydrogen sulphide (H<sub>2</sub>S), methane (CH<sub>4</sub>), ammonia (NH<sub>3</sub>), etc. The gasses have highly toxic and flammable properties, in particular hydrogen sulphide is toxic to humans in concentrations as low as 10 parts per million and its flammable vapours are heavier than air so that potentially lethal pockets of gas may accumulate in enclosed spaces.

**5.1.2.13 Anaerobic conditions** – conditions in sewage system leading to the production of toxic and flammable sewage gasses.

**5.1.2.14 Special area** – sea areas determined in MARPOL 73/78, Annex IV, Regulation 5 bis.

**5.1.2.15 Passenger** – every person other than the master and the crew members or other persons employed or engaged in any capacity onboard a ship on the business of that ship, and children under one year of age.

**5.1.2.16 Passenger ship** – a ship which carries more than twelve passengers.

**5.1.2.17 New passenger ship** – a passenger ship for which the building contract is placed, or in the absence of a building contract, the keel of which is laid, or which is in a similar stage of construction, on or after 1st June 2019, or the delivery of which is on or after 1st June 2021.

**5.1.2.18 Existing passenger ship** – a passenger ship which is not a new passenger ship.

### 5.1.3 Scope of supervision

**5.1.3.1** Intentionally blank.

**5.1.3.2** Supervision during manufacture shall cover:

- .1 sewage treatment plant including belonging pipeline, pumps and electrical equipment, dosimeters and monitoring and control devices;
- .2 holding tanks and the associated equipment.

**5.1.3.3** The supervision of monitoring on board shall cover:

- .1 sewage treatment plant;
- .2 comminution and disinfection plant;
- .3 holding tanks;
- .4 pumps and sewage piping.

**5.1.3.4** Before the manufacture is commenced, the following documentation shall be submitted to the *Register* for approval:

- .1 technical description and the principle of the plant operation, operating and maintenance manual;
- .2 general plan with cross sections of the sewage treatment plant, holding tank drawing;
- .3 monitoring and control scheme;
- .4 electrical schemes;
- .5 testing program.

## 5.2 ARRANGEMENT AND EQUIPMENT FOR TREATMENT AND DISCHARGE OF SEWAGE

### 5.2.1 General requirements

**5.2.1.1** Ships specified in 5.1.1 shall be fitted with anyone of this kind of equipment:

- .1 a type approved sewage treatment plant including a holding tank, which shall meet operational requirements based on standards and the test methods developed by the Organisation (IMO Res. MEPC.159(55));
- .2 approved system to comminute and disinfect the sewage (black water), including a holding tank, for the later discharge at sea at a distance more than 3 Nm from the nearest land.
- .3 a holding tanks for the later discharge of sewage into the reception facilities or other ship's facilities, or the discharge at sea at a distance more than 12 Nm from the nearest land at a moderate rate approved by *Register* when the ship is en route and proceeding at not less than 4 knots, the capacity of such tank shall be to the satisfaction of the *Register* for the retention of all sewage having regard to the operation of the ship, the number or persons on board and other relevant factors.

**5.2.1.2** Every passenger ship while in a special area shall be equipped with one of the following sewage systems:

- .1 a type approved sewage treatment plant, which shall meet operational requirements taking into account the standards and test methods developed by the Organisation (IMO Res. MEPC.227(64) and IMO Res. MEPC.284(70));
- .2 a holding tank of the construction and capacity to the satisfaction of the Register for the retention of all sewage for the later discharge into the reception facilities, with regard to the operation of the ship, number of persons onboard and other relevant factors. The holding tank shall have means to indicate visually the amount of its contents.

**5.2.1.3** Category A and B ships constructed on or after 1st January 2017 and all passenger ships constructed on or after 1st January 2017 are allowed to discharge sewage within polar waters when the ship has in operation a sewage treatment plant approved in accordance with 5.2.1.1.1 or 5.2.1.2.1, and as far as practicable from the nearest land, any ice-shelf, fast ice or areas of ice concentration exceeding 1/10.

**5.2.1.4** Category A and B ships that operate in areas of ice concentrations exceeding 1/10 for extended periods of time, may only discharge sewage using a sewage treatment plant approved in accordance with 5.2.1.1.1 or 5.2.1.2.1.

**5.2.1.5** Sewage effluent system shall be such as to avoid the uncontrolled discharge into the sea.

**5.2.1.6** Piping, electrical equipment and automation shall comply with the requirements of the *Rules for the classification of ships, Part 7 - Machinery, Part 8 - Piping, Part 12 - Electrical Equipment, Part 13 - Automation*.

On ships with area of navigation 6-8, of less than 400 tons gross tonnage, plastic pipes in sanitary water system outside machinery space, need not be type approved according to IMO Res. A. 753 (18), if plastic pipes comply with the requirements of recognised standards and their range of application includes black and grey water piping.

**5.2.1.7** Sewage pipeline shall be of the adequate dimensions as to avoid its clogging or revert circulation of sewage. Pipeline shall be protected from freezing.

**5.2.1.8** Sewage pipeline shall not pass through spaces where food is stored, prepared or served, or through pantries. Where these requirement cannot be complied with, due to structural reasons, provisions shall be made for alternatives, in which the part of pipeline passing through the mentioned spaces has no removing connection or such connections are minimised and so protected as to prevent leakage of sewage into such space.

Drain openings shall not be fitted on the pipeline section passing through above mentioned spaces.

Sewage pipeline shall not pass through medical spaces.

**5.2.1.9** Pipelines shall be tested for tightness in compliance with 5.2.3.7.

**5.2.1.10** Adequate air vents shall be fitted to the piping network, paying special attention to the extremities of the system. These should ensure an adequate supply of air and obviate any tendency for plugs of water to form within the system, tending to syphon or create vacuums thus removing water seals, when moving through the pipes especially under the action of violent rolling or pitching.

The arrangement of the venting pipes shall be in accordance with 5.2.2.7.

**5.2.1.11** In general, the sewage system shall be of a design, which will avoid potential risk of hazardous gasses within the system. The primary safety features should be incorporated in the design and operation of a sewage system and the barriers between the sewage gasses such as water traps of the toilet bowls, ventilation of the pipework and tanks should only be considered as secondary means of protection. The primary objective shall be the prevention of the production and accumulation of the toxic and flammable sewage gasses within the system.

**5.2.1.12** It is recommended that toilet bowls be often fitted with a vacuum breaking arrangements at the back of the water trap such as individual air pipes or patented backflow prevention valves.

**5.2.1.13** When the sewage is mixed with wastes or waste water covered by other chapters of present Rules, the requirements of those chapters shall be complied with in addition to the requirements of this chapter.

## 5.2.2 Sewage holding tanks

**5.2.2.1** Total capacity of all holding tanks may be determined by the formulae:

$$V = f \cdot n \cdot q \cdot t \quad [\text{lit}] \quad (5.2.2.1)$$

where:

- $f$  – exploitation factor:
  - = 1,0 for ships of non-restricted and restricted area of navigation, if the voyage takes more than 8 hours;
  - = 0,3-0,5 for passenger ships, if the voyage takes 2 till 4 hours;
  - = 0,1 for passenger ships, if the voyage takes up to 2 hours;
- $n$  – number of persons;
- $q$  – quantity of effluent (sewage) in litres per person a day:
  - = 70 lit/person a day, if collecting black water sewage
  - = 180-230 lit/person a day, if collecting black water sewage and grey water sewage from the domestic and accommodation space (large quantities for passenger ships):
  - = 25 lit/person a day, if collecting black water sewage with vacuum system
  - = 135-185 lit/person a day, if collecting black water sewage with vacuum system and grey water sewage from the domestic and accommodation space (large quantities for passenger ships):
- $t$  – time of the ship's stay in port and/or the area where the discharge is not permitted;
  - = 1 day for passenger ships on one-day touristic excursions
  - = 3-5 days for tankers in non-restricted area of navigation;
  - = 3-10 days for cargo ships in non-restricted area of navigation;
  - = 3 days for other ships;
  - = 2 days for the ships provided with the sewage treatment plants.

**5.2.2.2** Structural holding tanks shall comply with the requirements of the *Rules for the classification of ships, Part 2 - Hull*.

**5.2.2.3** Holding tanks shall be made of steel or stainless steel. On ships whose hull is manufactured from aluminium alloys or plastic materials, collecting tanks may be manufactured from these materials. The internal surfaces shall be smooth (except those of structural tanks) and protected against reaction of the liquid being carried. The tank bottom shall be inclined towards suction pipe. Tanks shall be provided with the washing machine using water or steam and the openings for inspection and cleaning. Mixture device for mixing sewage is recommended to be installed.

Washing machine for holding tanks need not to be installed on ships with area of navigation 5-8.

**5.2.2.4** Holding tanks shall be segregated (dry spaces or cofferdams) from drinking water and boiler water tanks, fresh water tanks, vegetable oil tanks as well as from accommodation and cargo spaces. Holding tanks may be without cofferdams in machinery and cargo spaces provided that such spaces are not intended for the carriage of eatables and products.

**5.2.2.5** Prior to protection coating, holding tanks shall be tested by test pressure 1.5 times above the water column pressure measured from bottom to the lowest sanitary equipment which has no possibility of closing the discharge outlet, but not less than 2.5 m of the water column.

**5.2.2.6** Holding tanks shall be provided with audible and visual alarms to warn that the level in tank exceeds 80% of the tank depth.

**5.2.2.7** Ventilation pipes to collection, storage and treatment tanks shall be of adequate size to minimise pressure drop and to ensure satisfactory clearance of sewage gasses. The size of the vent pipes should also be sufficient to vent any air from blowers or from vacuum collection system discharges if installed.

The venting pipes shall be led to a safe place on open deck, clear of any sources of ignition, in a such a way that its opening is at least 3 m above the highest sanitary spaces and protected with a non-corrosive mesh.

Ventilation pipes shall be self-drained at all angles of heel and trim and so arranged to avoid giving of smell into accommodation, public, working and medical spaces.

**5.2.2.8** The design of the tank may include features to maintain an adequate oxygen level in the liquid, thereby eliminating anaerobic conditions. This may be achieved by direct air injection, or by air entrainment into the liquid whilst pumping through an ejector nozzle, etc.

### 5.2.3 Sewage treatment plants

**5.2.3.1** The capacity of sewage treatment plant shall be determined by the formulae:

$$Q = n \cdot q \text{ [lit/day]} \quad (5.2.3.1)$$

where  $n$  and  $q$  are the same as in 5.2.2.1.

**5.2.3.2** Sewage treatment plants, associated pumps, piping and their outfitting which come in contact with sewage effluent shall be of the material resistant to its hazardous reaction or shall be specially protected.

**5.2.3.3** If chlorine is used for the disinfection of sewage effluent, the chlorine content in the water discharged into sea shall not exceed 0,5 mg/lit.

**5.2.3.4** The sewage treatment plant shall ensure the following effluent standard:

- .1 biochemical oxygen demand (BOD<sub>5</sub>):  
25 mg/lit
- .2 chemical oxygen demand (COD):  
125 mg/lit
- .3 total suspended solids:
  - .1 when the plant is tested in land:  
35 mg/lit
  - .2 when the plant is tested on board:  
 $x + 35$  mg/lit

$x$  - the content of suspended solids in water for flushing of the sewage treatment plant [mg/lit]

- .4 faecal coliform bacteria: 100/100 ml
- .5 pH value: 6-8,5

**5.2.3.5** The sewage treatment plant installed on a passenger ship intending to discharge sewage effluent in special areas shall additionally meet the following effluent standards for the geometric mean of the total nitrogen and phosphorus content of the samples of effluent taken during the test period:

- .1 total nitrogen: 20 mg/lit or at least 70% reduction in relation to influent load
- .2 total phosphorus: 1,0 mg/lit or at least 80% reduction in relation to influent load.

**5.2.3.6** The treatment plant shall be tested for tightness in accordance with 5.2.2.5.

**5.2.3.7** Pipelines shall be tested with test pressure:

$$p_{ts} = 1,5 \cdot p \quad [\text{MPa}] \quad (5.2.3.6)$$

where:

$p$  – working pressure.

**5.2.3.8** Functional testing of the plant shall be carried out in the factory or on board in compliance with the program approved by *the Register*.

**5.2.3.9** The plants may be located in the machinery space or in the gastight spaces with forced ventilation.

**5.2.3.10** The efficient system of washing and disinfection of the plant shall be provided as well as the control system and pipeline (opening for inspection and repair shall be also provided).

**5.2.3.11** Provisions shall be made for the automatic operation of the plant and for audible and visual alarm in case of overflow or in case of malfunction of the plant.

**5.2.3.12** The plant shall be provided with the vent pipe arranged in accordance with 5.2.2.7.

**5.2.3.13** Prior to and after the treatment, provisions shall be made for taking the samples of effluent.

**5.2.3.14** The ship shall have onboard operating and maintenance manual for the sewage treatment plant.

The type and model of the sewage treatment plant and the name of the manufacturer, date of manufacture and any operational or installation limits shall be noted on a durable label firmly affixed on the plant.

### 5.2.4 Sewage system to comminute and disinfect

**5.2.4.1** Sewage system to comminute and disinfect shall comply with the requirements 5.2.3.1 to 5.2.3.3 and 5.2.3.8 to 5.2.3.13.

**5.2.4.2** Holding tanks in relation with the system shall comply with the requirements of chapter 5.2.2.

**5.2.4.3** The system shall comminute solid substances in sewage to the particles not exceeding 25 mm.



## 5.2.5 Discharge of sewage

**5.2.5.1** Two pumps shall be provided for the discharge of sewage effluent. One ejector may be provided instead of a pump. Exceptionally, the *Register* may permit the fitting of one pump only.

**5.2.5.2** Every ship shall be provided with a pipeline for the discharge of sewage into reception facilities. The pipeline on either side of the ship shall be provided with the international discharge connection according to Fig.5.2.5.2. For smaller ships The *Register* may permit only one discharge connection. Discharge outlets shall be provided with blank flanges.

A position on the deck where the effluent discharge may be visually observed shall be provided with means for stopping the discharge pumps or with a positive communication system with a discharge control position. The ships of less than 30 m in length, subject to the agreement with the *Register*, need not be provided with the remote control or a communication system.

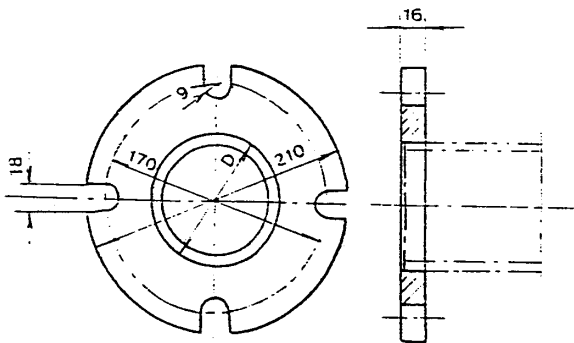

**Figure 5.2.5.2**  
**Standard flange of discharge connection**

The flange is designed to accept pipes up to a maximum internal diameter of 100 mm and shall be of steel or other equivalent material having a flat face. This flange, together with a suitable gasket, shall be suitable for a service pressure of 0.6 MPa. Fastening bolts to be M 16.

For ships having a moulded depth of 5 metres and less, the inner diameter of the discharge connection may be 38 millimetres.

**5.2.5.3** For ships in dedicated trades, i.e. passenger ferries, alternatively the ship's discharge pipeline may be fitted with a discharge connection which can be accepted by the *Register*, such as quick connection couplings.

## 6 PREVENTION OF POLLUTION BY GARBAGE

### 6.1 GENERAL

#### 6.1.1 Application

**6.1.1.1** Annex V, MARPOL 73/78 entered into force on 31<sup>st</sup> December 1988.

**6.1.1.2** This Chapter of present Rules apply to the arrangement and equipment of ships intended for prevention of pollution by garbage.

**6.1.1.3** The requirements of this Chapter of present Rules apply to all ships.

#### 6.1.2 Definitions

The explanation of terms and expressions, used in all chapters, is specified in Chapter 1 - General. The following terms and expressions are applied in the present Chapter:

**6.1.2.1 Wastes** – means useless, unneeded or superfluous matter which is to be discharged.

**6.1.2.2 Garbage** – means all kinds of food wastes, domestic and operational wastes, all plastics, cargo residues, cooking oil, fishing gear and animal carcasses (excluding fresh fish and parts thereof), generated during the normal operation of the ship and liable to be disposed of continuously or periodically except those substances which are defined or listed in other Chapters to the present Rules (for example oils, chemicals, etc).

**6.1.2.3 Incinerator** – means shipboard facilities for incinerating solid wastes approximating in composition to household waste and liquid wastes arising from the operation of the ship, e.g., domestic waste, cargo residues, cargo-associated waste, maintenance waste, operational waste and fishing gear, etc. These facilities may be designed to use or not to use the heat energy produced.

**6.1.2.4 Equipment for processing garbage** – (comminuter, grinder, compactor) means the equipment for comminution of garbage or to reduce its volume.

**6.1.2.5 Garbage collecting equipment** – means containers and other equipment for collecting and storage of garbage.

**6.1.2.6 Number of persons** – means crew, passengers and special staff (personnel) in relation to number of places intended for their accommodation on board.

**6.1.2.7 Special areas** – for the purpose of Regulations in this chapter, areas determined in MARPOL 73/78, Annex V, Regulation 1(14).

#### 6.1.3 Scope of supervision

**6.1.3.1** Intentionally blank.

**6.1.3.2** The *Register* shall carry out supervision during manufacture over:

- .1 incinerators;
- .2 equipment for processing garbage;
- .3 monitoring and control device.

**6.1.3.3** The *Register* shall carry out supervision during mounting on board ship over:

- .1 incinerator;
- .2 equipment for processing garbage,
- .3 garbage collection equipment.

**6.1.3.4** Prior to the commencement of the manufacture, the documentation which shall be submitted to The *Register* for approval is the following:

- .1 Incinerator:
  - .1 technical description and work principle;
  - .2 general plan with cross sections (design, capacity, scantlings, materials and protection);
  - .3 firing (burning) device drawing;
  - .4 fill-up device drawing;
  - .5 fuel scheme;
  - .6 electrical scheme;
  - .7 monitoring and control scheme;
  - .8 testing program.
- .2 Equipment for processing garbage:

Documentation referred to in 6.1.3.4-.1 excluding items 3, 4 and 5.
- .3 Garbage collection equipment:
  - .1 drawing of the equipment and cross sections (design, capacity, scantlings, materials and protection)
  - .2 capacity calculation.

## 6.2 ARRANGEMENT AND EQUIPMENT FOR COLLECTION AND PROCESSING OF GARBAGE AND INCINERATION OF WASTES

### 6.2.1 General requirements

**6.2.1.1** Every ship shall be provided with the one of the following equipment:

- .1 garbage collecting equipment; or
- .2 garbage processing equipment; or
- .3 garbage incinerator.

**6.2.1.2** Garbage processing equipment's and wastes incinerators shall comply with the requirements of the *Rules for the classification of ships, Part 8 - Piping, Part 12 - Electrical equipment* and *Part 13 - Automation*.

### 6.2.2 Garbage collection equipment

**6.2.2.1** The equipment may be portable or incorporated into hull structure but not into double bottom structure.

**6.2.2.2** The capacity of the garbage collection equipment is recommended to be determined by the formulae:

$$V = n \cdot q \cdot t \cdot 10^{-3} \text{ [m}^3\text{]} \quad (6.2.2.2)$$

where:

- $n$  – number of persons;
- $q$  – 5 dm<sup>3</sup> per person (daily rate of garbage per person);
- $t$  – time of the ship's stay in areas where garbage disposal is not permitted;
  - = 3 to 10 days for dry cargo carriers (ships) of non-restricted area of navigation;
  - = 3 to 6 days for tankers of non-restricted area of navigation;
  - = 3 days for other ships.

All ships operating in the Antarctic area shall have sufficient capacity of garbage collection equipment, for the retention of all garbage while in the area, in order to discharge it to reception facilities.

**6.2.2.3** Garbage collection equipment incorporated into hull structure shall be of steel. Inside wall surface shall be smooth and the bottom inclined 30° towards the discharge outlet. The discharge outlets shall not be provided with collar on the lower part.

Covers of the discharge outlets shall be provided with the opening device enabling safe operation under all conditions of navigation.

**6.2.2.4** Inside surfaces of the portable garbage collection equipment shall be smooth.

**6.2.2.5** Portable equipment shall be attached securely on board (securing device).

**6.2.2.6** Openings for garbage shall be provided with covers which can be securely closed.

### 6.2.3 Garbage processing equipment

**6.2.3.1** Comminuters shall comminute garbage to the particles not exceeding 25 mm.

**6.2.3.2** Compactors shall reduce the volume of garbage at least 12 times.

**6.2.3.3** The equipment for the discharge of processing garbage into sea shall be located under the deck and shall be provided with watertight covers.

**6.2.3.4** The equipment for the discharge of processing garbage provided with plates with instruction for their use.

### 6.2.4 Equipment for incineration of garbage (incinerators)

**6.2.4.1** Incinerators, in addition to the possibility of direct charge with garbage, shall be provided with a storage receptacle for garbage (waste).

Covers on the garbage storage receptacle shall be provided with the stopping device which precludes simultaneous opening of two or several covers. If storage (charge) of some materials for incinerator is limited (e.g. waste oil, oil residue, etc.) such limitations shall be clearly indicated on the table fitted in the conspicuous place.

**6.2.4.2** Provision shall be made for the control of combustion process directly or indirectly.

**6.2.4.3** Burning units (burners) or other fuel supply devices shall be of the type approved by the *Register*.

**6.2.4.4** Fuel supply line shall be provided with a device which enable the supply of fuel only:

- .1 when the burner is ready to operate;
- .2 when the combustion air is flowing into the combustion chamber.

**6.2.4.5** Fuel supply line shall be provided with a device for automatic shut down of the fuel supply to the burner in intervals not exceeding 5 seconds, if:

- .1 combustion air supply to combustion chamber is cut off;
- .2 the flame is gone out;
- .3 failure of electrical supply;
- .4 fuel pressure drop is under the permissible working pressure.

**6.2.4.6** In case that the fuel does not ignite within 5 seconds, the fuel supply shall be automatically shut down.

**6.2.4.7** The burners shall be capable of being shut down from two positions, one of which shall be outside of the space where the incinerator is located.

**6.2.4.8** Drip trays shall be fitted on places where fuel leakage might occur with the possibility of efficient discharge.

**6.2.4.9** The ash and other combustion remains shall be stored in the portable receptacles with covers which can be securely attached on board (securing device).

**6.2.4.10** The incinerator surfaces exposed to excessive heating shall be insulated in accordance with the requirements of the *Rules for the classification of ships, Part 7 - Machinery installation*, 1.11.9.

**6.2.4.11** The exhaust gas system shall be in accordance with the *Rules for the classification of ships, Part 8 - Piping*, Chapter 6.

**6.2.4.12** Burner automatic ignition program shall be:

- combustion space to be ventilated at least 3 minutes prior to ignition;
- combustion space to be ventilated at least 3 minutes after the flame is gone.

In case that a separate blower for the extended operation is provided after the flame is gone, the latter requirement need not be fulfilled.

**6.2.4.13** Incinerators with the automatic combustion process shall be provided with alarm for the cases referred to in the Table 6.2.4.13.

**6.2.4.14** When charging the combustion chamber of incinerator which is not provided with the storage receptacle, the combustion chamber door shall be capable of being blocked in case that:

- .1 during combustion air supply for combustion chamber;
- .2 the temperature in combustion chamber exceeds the flash point of fuel evaporations being used on board.

**6.2.4.15** Incinerator plants with capacities up to 4000 kW per unit shall be in compliance with MARPOL 73/78,

Annex V, Guidelines for the implementation of Annex V, i.e. IMO Res. MEPC.244(66).

**6.2.4.16** Requirements related to shipboard incineration related to the prevention of air pollution are stated in 7.3.5.

**6.2.5 Arrangements and equipment location**

**6.2.5.1** Portable garbage collection equipment shall be located on the open deck or in the spaces separated from the accommodation and service spaces which can be with forced ventilation.

**6.2.5.2** Comminuters and compactors shall be located in the spaces separated from accommodation and service spaces which can be with forced ventilation.

**6.2.5.3** Incinerators may be located in the machinery spaces or in (special) separate spaces.

- .1 If located in the machinery space it shall be separated by screen and shall be in accordance with the *Rules for the classifica-*

*tion of ships, Part 7 - Machinery* 1.12 and 1.13.

- .2 If located in separate space, such a space shall be considered as service space and shall be in accordance with the *Rules for the classification of ships, Part 17 - Fire-fighting*, 1.5.8.1.

**6.2.5.4** In case that incinerator is located in separate space, provision shall be made for:

- .1 Pressure-vacuum ventilation which provide sufficient quantity of air for the incinerator operation;
- .2 Automatic fire alarm in accordance with for the *Rules for the classification of ships, Part 17 - Fire-fighting*.
- .3 Fire-fighting system in accordance with the *Rules for the classification of ships, Part 17 - Fire-fighting*.

**Table 6.2.4.13**  
Monitoring of incinerators

		Alarm	Fuel automatic shut-off	Remarks
1		2	3	4
High temperature of exhaust gases		-	+	
High temperature in combustion chamber		-	+	
Ventilator switch-off		-	+	If suction ventilator is not available, stand-by ventilator is put in operation
Suction ventilator switch-off		-	+	If fitted
Fuel temperature	high	+	-	
	low	+	-	High viscosity
Fuel pump low pressure		-	+	If fuel pump in necessary in normal work
Flame is gone or failure		-	+	Each burning valve shall have possibility of automatic shut-off of fuel supply
Fuel supply failure or combustion air low pressure		-	+	
Automatic shut-off fuel supply		+	-	

## 6.3 PLACARDS, GARBAGE MANAGEMENT PLANS, GARBAGE RECORD BOOK

ship is entitled to fly and for ships engaged in international voyages also in English, French or Spanish.

### 6.3.1 Placards

**6.3.1.1** Every ship of 12 m or more in length overall and fixed or floating platforms shall display at appropriate places placards with guidelines for disposal of garbage.

**6.3.1.2** Placards shall be made of durable material, with dimensions of not less than 200 x125 mm and displayed at visible place on navigating bridge, dining rooms and on open deck, and for passenger ships also at places inside the ship and on open deck where more passenger gather.

#### 6.3.1.3 Ships engaged in international voyages

Ships shall have placards written in the working language of the crew and additionally in English, French or Spanish with text according to MARPOL 73/78, Annex V, Regulation 3, 4, 5 and 6, and section 5.2 of part II-A of the Polar Code.

#### 6.3.1.4 Ships of restricted service 5 to 8

Since according to MARPOL 73/78, Annex V, Regulation 3, the disposal of garbage is prohibited in Adriatic sea area, except as provided otherwise in Regulation 6, the placard with clearly written warning about the prohibition of disposal of garbage into the sea is to be displayed.

On passenger ships the placard is to be displayed in accommodation spaces and on open decks, and on other ships at least in dining room.

### 6.3.2 Garbage management plan

**6.3.2.1** Every ship of 100 GT and above and every ship certified to carry 15 persons or more and fixed or floating platforms shall carry a garbage management plan.

**6.3.2.2** Garbage management plan shall provide written procedures for minimizing, collecting, storing, processing and disposing of garbage, including the use of the equipment onboard, and designate the person in charge of carrying out the plan.

Plan written in the working language of the crew is to be in accordance with IMO Res. MEPC.220 (63).

### 6.3.3 Garbage record book

**6.3.3.1** Every ship of 400 GT and above and every ship certified to carry 15 persons or more engaged in international voyages and every fixed or floating platform shall be provided with a garbage record book.

Garbage record book shall be provided on every ship of 400 GT and above and every ship certified to carry 15 persons or more, if the duration of the voyage is more than one hour, in the restricted service area 5 to 8.

**6.3.3.2** The entries in the garbage record book, according to form in appendix to the Annex V, MARPOL 73/78, shall be in an official language of the state whose flag the

## 7 PREVENTION OF AIR POLLUTION

### 7.1 GENERAL

#### 7.1.1 Application

**7.1.1.1** The Protocol of 1997, to amend the *International Convention for the Prevention of Pollution from Ships, 1973, as modified by the Protocol of 1978 relating thereto* (i.e. *MARPOL 73/78 Convention*) entered into force on 19 May 2005. This Protocol introduced the Annex VI to the Convention, entitling the regulations for the prevention of air pollution from ships.

IMO Res. MEPC.176(58) Amendments to the annex of the Protocol of 1997 to amend the International Convention for the Prevention of Pollution from Ships, 1973, as modified by the Protocol of 1978 relating thereto (i.e. Revised MARPOL Annex VI) was adopted on 10 October 2008 and enters into force on 1 July 2010.

IMO Res. MEPC.177(58) Amendments to the Technical Code on Control of Emission of Nitrogen Oxides from Marine Diesel Engines, i.e. NOx Technical Code 2008 was also adopted on 10 October 2008 and enters into force on 1 July 2010.

**7.1.1.2** The provisions of this Chapter shall apply to all ships (as defined in item 1.1.2.4), except where expressly provided otherwise in items 7.1.3, 7.2.1, 7.2.2, 7.3.2, 7.3.4, 7.3.5 and 7.3.6.

#### 7.1.2 Definitions

The explanations of terms and expressions that refer to the general terminology in the *Rules are given in the Rules for the classification of ships, Part 1 - General requirements, Chapter 1 - General information*. For the purpose of this chapter of the Rules the following definitions apply.

**7.1.2.1 Annex** – means Annex VI to the *International Convention for the Prevention of Pollution from Ships 1973 (MARPOL)*, as modified by the Protocol of 1978 relating thereto, and as modified by the Protocol of 1997, as amended by the IMO, provided that such amendments are adopted and brought into force.

**7.1.2.2 A similar stage of construction** – means the stage at which:

- .1 construction identifiable with a specific ship begins; and
- .2 assembly of that ship has commenced comprising at least 50 tonnes or one per cent of the estimated mass of all structural material, whichever is less.

**7.1.2.3 Anniversary date** – means the day and the month of each year which will correspond to the date of expiry of the *International Air Pollution Prevention Certificate*.

**7.1.2.4 Auxiliary control device** – means a system, function, or control strategy installed on a marine diesel engine that is used to protect the engine and/or its ancillary equipment against operating conditions that could result in

damage or failure, or that is used to facilitate the starting of the engine. An auxiliary control device may also be a strategy or measure that has been satisfactorily demonstrated not to be a defeat device.

**7.1.2.5 Continuous feeding** – is defined as the process whereby waste is fed into a combustion chamber without human assistance while the incinerator is in normal operating conditions with the combustion chamber operative temperature between 850°C and 1200°C.

**7.1.2.6 Defeat device** – means a device which measures, senses, or responds to operating variables (e.g., engine speed, temperature, intake pressure or any other parameter) for the purpose of activating, modulating, delaying or deactivating the operation of any component or the function of the emission control system such that the effectiveness of the emission control system is reduced under conditions encountered during normal operation, unless the use of such a device is substantially included in the applied emission certification test procedures.

**7.1.2.7 Emission** – means any release of substances, subject to control by this Chapter from ships into the atmosphere or sea.

**7.1.2.8 Emission Control Area** – means an area where the adoption of special mandatory measures for emissions from ships is required to prevent, reduce and control air pollution from NOx or SOx and particulate matter or all three types of emissions and their attendant adverse impacts on human health and the environment. Emission Control Areas shall include those listed in, or designated under, 7.3.2 and 7.3.3.

**7.1.2.9 Fuel oil** – means any fuel delivered to and intended for combustion purposes for propulsion or operation on board a ship, including gas, distillate and residual fuels.

**7.1.2.10 Gross tonnage** – means the measure of the overall size of a ship determined in accordance with the *Rules for tonnage measurement of maritime objects* (see item 1.3.1 of these Rules).

**7.1.2.11 Installations** – in relation to 7.3.1 means the installation of systems, equipment including portable fire-extinguishing units, insulation, or other material on a ship, but excludes the repair or recharge of previously installed systems, equipment, insulation, or other material, or the recharge of portable fire-extinguishing units.

**7.1.2.12 Installed** – means a marine diesel engine that is fitted, or is intended to be fitted, on a ship, including a portable auxiliary marine diesel engine, only if its fuelling, cooling, or exhaust system is an integral part of the ship. A fuelling system is considered integral to the ship only if it is permanently affixed to the ship. This definition includes a marine diesel engine that is used to supplement or augment the installed power capacity of the ship and is intended to be an integral part of the ship.

**7.1.2.13 Irrational emission control strategy** – means any strategy or measure that, when the ship is operated under normal conditions of use, reduces the effectiveness of an emission control system to a level below that expected on the applicable emission test procedures.

**7.1.2.14 Marine diesel engine** – means any reciprocating internal combustion engine operating on liquid or dual

fuel, to which 7.3.2 applies, including booster/compound systems if applied. In addition, a gas fuelled engine installed on a ship constructed on or after 1 March 2016 or a gas fuelled additional or non-identical replacement engine installed on or after that date is also considered as a marine diesel engine.

**7.1.2.15 NO<sub>x</sub> Technical Code** – means the *Technical code on control of emission of nitrogen oxides from marine Diesel engines* adopted by resolution 2 of the 1997 MARPOL Conference, as amended by the IMO.

**7.1.2.16 Ozone-depleting substances** – means controlled substances defined in paragraph (4) of article 1 of the *Montreal Protocol on Substances that Deplete the Ozone Layer*, 1987, listed in Annexes A, B, C or E to the said Protocol.

Ozone-depleting substances that may be found on board ship include, but are not limited to:

Halon 1211	Bromochlorodifluoromethane
Halon 1301	Bromotrifluoromethane
Halon 2402	1,2-Dibromo-1,1,2,2-tetrafluoroethane (also known as Halon 114B2)
CFC-11	Trichlorofluoromethane
CFC-12	Dichlorodifluoromethane
CFC-113	1,1,2-Trichloro-1,2,2-trifluoroethane
CFC-114	1,2-Dichloro-1,1,2,2-tetrafluoroethane
CFC-115	Chloropentafluoroethane

**7.1.2.17 Shipboard incineration** – means the incineration of wastes or other matter on board a ship, if such wastes or other matter were generated during the normal operation of that ship.

**7.1.2.18 Shipboard incinerator** – means a shipboard facility designed for the primary purpose of incineration.

**7.1.2.19 Ships constructed** – means ships the keels of which are laid or which are at a similar stage of construction.

**7.1.2.20 Sludge oil** – means sludge from the fuel or lubricating oil separators, waste lubricating oil from main or auxiliary machinery, or waste oil from bilge water separators, oil filtering equipment or drip trays.

**7.1.2.21 Tanker** – means an oil tanker as defined in item 2.1.2.5, or a chemical tanker as defined in item 3.1.2.1.

## 7.1.3 Exceptions and Exemptions

### 7.1.3.1 General

Regulations of this Chapter of the *Rules* shall not apply to:

- .1 any emission necessary for the purpose of securing the safety of a ship or saving life at sea; or
- .2 any emission resulting from damage to a ship or its equipment:
  - .1 provided that all reasonable precautions have been taken after the occurrence of the damage or discovery of the emission for the purpose of preventing or minimising the emission; and
  - .2 except if the owner or the master acted either with intent to cause damage,

or recklessly and with knowledge that damage would probably result.

### 7.1.3.2 Trials for Ship Emission Reduction and Control Technology Research

The Administration may, in co-operation with other Administrations as appropriate, issue an exemption from specific provisions of this Chapter for a ship to conduct trials for the development of ship emission reduction and control technologies and engine design programmes. Such an exemption shall only be provided if the applications of specific provisions of this Chapter or the *NO<sub>x</sub> Technical Code 2008* could impede research into the development of such technologies or programmes. A permit for such an exemption shall only be provided to the minimum number of ships necessary and be subject to the following provisions:

- .1 for marine diesel engines with a per cylinder displacement up to 30 litres, the duration of the sea trial shall not exceed 18 months. If additional time is required, the Administration or the permitting Administrations may permit a renewal for one additional 18-month period; or
- .2 for marine diesel engines with a per cylinder displacement at or above 30 litres, the duration of the ship trial shall not exceed 5 years and shall require a progress review by the Administration or the permitting Administrations at each intermediate survey. A permit may be withdrawn based on this review if the testing has not adhered to the conditions of the permit or if it is determined that the technology or programme is not likely to produce effective results in the reduction and control of ship emissions. If the Administration or the reviewing Administration determine that additional time is required to conduct a test of a particular technology or programme, a permit may be renewed for an additional time period not to exceed five years.

### 7.1.3.3 Emissions from Sea-bed Mineral Activities

Emissions directly arising from the exploration, exploitation and associated offshore processing of sea-bed mineral resources are exempt from the provisions of this Chapter. Such emissions include the following:

- .1 emissions resulting from the incineration of substances that are solely and directly the result of exploration, exploitation and associated offshore processing of sea-bed mineral resources, including but not limited to the flaring of hydrocarbons and the burning of cuttings, muds, and/or stimulation fluids during well completion and testing operations, and flaring arising from upset conditions;
- .2 the release of gases and volatile compounds entrained in drilling fluids and cuttings;
- .3 emissions associated solely and directly with the treatment, handling, or storage of sea-bed minerals; and
- .4 emissions from marine diesel engines that are solely dedicated to the exploration, exploitation and associated offshore processing of sea-bed mineral resources.

The requirements of 7.3.6 shall not apply to the use of hydrocarbons which are produced and subsequently used on site as fuel.

#### 7.1.4 Equivalents

**7.1.4.1** The *Administration* may allow any fitting, material, appliance or apparatus to be fitted in a ship or other procedures, alternative fuel oils, or compliance methods used as an alternative to that required by this of if such fitting, material, appliance or apparatus or other procedures, alternative fuel oils, or compliance methods are at least as effective in terms of emissions reductions as that required by this chapter, including any of the standards set forth in 7.3.2 and 7.3.3.

**7.1.4.2** The *Administration* which allows a fitting, material, appliance or apparatus or other procedures, alternative fuel oils, or compliance methods used as an alternative to that required by this chapter shall communicate to the IMO for circulation to the Parties particulars thereof, for their information and appropriate action, if any.

**7.1.4.3** The *Administration* should take into account any relevant guidelines developed by the IMO pertaining to the equivalents provided for in this regulation 7.1.4.

**7.1.4.4** The *Administration* which allows the use of an equivalent as set forth in 7.1.4.1 shall endeavour not to impair or damage its environment, human health, property, or resources or those of other States.

**7.1.4.5** Guidelines for exhaust gas cleaning systems are set out in IMO Res. MEPC.259(68).

## 7.2 SURVEY, CERTIFICATION AND MEANS OF CONTROL

This chapter states the requirements specific to the prevention of air pollution from ships.

### 7.2.1 Surveys

**7.2.1.1** Every ship of 400 gross tonnage or above and every fixed and floating drilling rig and other platforms shall be subject to the surveys specified below:

- .1 **Initial survey** – before the ship is put into service or before the certificate required under 7.2.2 is issued for the first time. This survey shall be such as to ensure that the equipment, systems, fittings, arrangements and material fully comply with the applicable requirements of this Chapter;
- .2 **Renewal survey** – at intervals of five years, except where 7.2.3.2, 7.2.3.4 or 7.2.3.5 is applicable. The renewal survey shall be such as to ensure that the equipment, systems, fittings, arrangements and material fully comply with applicable requirements of this Chapter;
- .3 **Intermediate survey** – within three months before or after the second anniversary date or within three months before or after the third anniversary date of the certificate which shall take the place

of one of the annual surveys specified in 7.2.1.1-4.4. The intermediate survey shall be such as to ensure that the equipment and arrangements fully comply with the applicable requirements of this Chapter and are in good working order. Such intermediate surveys shall be endorsed on the certificate issued under 7.2.2.

.4 **Annual survey** – within three months before or after each anniversary date of the certificate, including a general inspection of the equipment, systems, fittings, arrangements and material referred to in 7.2.1.1-1 to ensure that they have been maintained in accordance with 7.2.1.3 and that they remain satisfactory for the service for which the ship is intended. Such annual surveys shall be endorsed on the certificate issued under 7.2.2; and

.5 **Additional survey** – either general or partial, according to the circumstances, shall be made whenever any important repairs or renewals are made as prescribed in 7.2.1.3 or after a repair resulting from investigations prescribed in 7.2.1.4. The survey shall be such as to ensure that the necessary repairs or renewals have been effectively made, that the material and workmanship of such repairs or renewals are in all respects satisfactory and that the ship complies in all respects with the requirements of this Chapter.

**7.2.1.2** All marine diesel engines over 130 kW, except those exempted by 7.1.3 or 7.3.2, are to comply with the 7.3.2 limit regardless of the gross tonnage of the ship onto which the engine is installed. In this context such engines must have an approved *Technical File* and must be issued with an EIAPP certificate in accordance with the *NOx Technical Code* in all cases.

Ship surveys specified in 7.2 do not apply to ships under 400 GT.

**7.2.1.3** Ship surveys specified in 7.4.4 do not apply to ships engaged on voyages within area of navigation 5 to 8 constructed before 1<sup>st</sup> January 2018, and to marine diesel engines installed onboard these ships before 1<sup>st</sup> January 2018.

**7.2.1.4** The equipment shall be maintained to conform with the provisions of this Chapter and no changes shall be made in the equipment, systems, fittings, arrangements, or material covered by the survey, without the express approval of the *Register*. The direct replacement of such equipment and fittings with equipment and fittings that conform with the provisions of this Chapter is permitted.

**7.2.1.5** Whenever an accident occurs to a ship or a defect is discovered which substantially affects the efficiency or completeness of its equipment covered by this Chapter, the master or owner of the ship shall report at the earliest opportunity the *Register* responsible for issuing the relevant certificate.



## 7.2.2 Issue or endorsement of a Certificate

**7.2.2.1** An *International Air Pollution Prevention Certificate* (i.e. *IAPP Certificate*) shall be issued after initial or renewal survey in accordance with the provisions of 7.2.1, to:

- .1 any ship of 400 gross tonnage or above engaged in voyages to ports or offshore terminals under the jurisdiction of other Parties to the Protocol of 1997; and
- .2 platforms and drilling rigs engaged in voyages to waters under the sovereignty or jurisdiction of other Parties to the Protocol of 1997.

**7.2.2.2** A ship constructed before the date of entry into force of Annex VI shall be issued with an *International Air Pollution Prevention Certificate* in accordance with 7.2.2.1 no later than the first scheduled dry-docking after the date of such entry into force, but in no case later than three years after this date.

## 7.2.3 Duration and validity of Certificate

**7.2.3.1** An *International Air Pollution Prevention Certificate* is issued for a period of five years.

**7.2.3.2** Notwithstanding the requirements of 7.2.3.1:

- .1 when the renewal survey is completed within three months before the expiry date of the existing certificate, the new certificate shall be valid from the date of completion of the renewal survey to a date not exceeding five years from the date of expiry of the existing certificate;
- .2 when the renewal survey is completed after the expiry date of the existing certificate, the new certificate shall be valid from the date of completion of the renewal survey to a date not exceeding five years from the date of expiry of the existing certificate; and
- .3 when the renewal survey is completed more than three months before the expiry date of the existing certificate, the new certificate shall be valid from the date of completion of the renewal survey to a date not exceeding five years from the date of completion of the renewal survey.

**7.2.3.3** If a renewal survey has been completed and a new certificate cannot be issued or placed on board the ship before the expiry date of the existing certificate, the *Register* may endorse the existing certificate and such a certificate shall be accepted as valid for a further period which shall not exceed five months from the expiry date.

**7.2.3.4** If a ship, at the time when a certificate expires, is not in a port in which it is to be surveyed, the *Register* may extend the period of validity of the certificate but this extension shall be granted only for the purpose of allowing the ship to complete its voyage to the port in which it is to be surveyed, and then only in cases where it appears proper and reasonable to do so. No certificate shall be extended for a period longer than three months, and a ship to which an extension is granted shall not, on its arrival in the port in which it

is to be surveyed, be entitled by virtue of such extension to leave that port without having a new certificate. When the renewal survey is completed, the new certificate shall be valid to a date not exceeding five years from the date of expiry of the existing certificate before the extension was granted.

**7.2.3.5** A certificate issued to a ship engaged on short voyages which has not been extended under the foregoing provisions of 7.2.3 may be extended by the *Register* for a period of grace of up to one month from the date of expiry stated on it. When the renewal survey is completed, the new certificate shall be valid to a date not exceeding five years from the date of expiry of the existing certificate before the extension was granted.

**7.2.3.6** If an annual or intermediate survey is completed before the period specified in 7.2.1, then:

- .1 the anniversary date shown on the certificate shall be amended by endorsement to a date which shall not be more than three months later than the date on which the survey was completed;
- .2 the subsequent annual or intermediate survey required by 7.2.1 shall be completed at the intervals prescribed by 7.2.1 using the new anniversary date; and
- .3 the expiry date may remain unchanged provided one or more annual or intermediate surveys, as appropriate, are carried out so that the maximum intervals between the surveys prescribed by 7.2.1 are not exceeded.

**7.2.3.7** A certificate issued under 7.2.2 shall cease to be valid in any of the following cases:

- .1 if the relevant surveys are not completed within the periods specified under 7.2.1.1;
- .2 if the certificate is not endorsed in accordance with 7.2.1.1-3 or 7.2.1.1-4; and
- .3 upon transfer of the ship to the flag of another State.

## 7.3 REQUIREMENTS FOR CONTROL OF EMISSIONS FROM SHIPS

### 7.3.1 Ozone-depleting substances

**7.3.1.1** Item 7.3.1 does not apply to permanently sealed equipment where there are no refrigerant charging connections or potentially removable components containing ozone depleting substances.

**7.3.1.2** Subject to the provisions of 7.1.3.1, any deliberate emissions of ozone depleting substances shall be prohibited. Deliberate emissions include emissions occurring in the course of maintaining, servicing, repairing or disposing of systems or equipment, except that deliberate emissions do not include minimal releases associated with the recapture or recycling of an ozone depleting substance. Emissions arising from leaks of an ozone depleting substance, whether or not the leaks are deliberate, may be regulated by Parties to the Protocol of 1997.

**7.3.1.3** Installations which contain ozone depleting substances, other than hydro-chlorofluorocarbons, shall be prohibited:

- .1 on ships constructed on or after 19 May 2005; or
- .2 in the case of ships constructed before 19 May 2005, which have a contractual delivery date of the equipment to the ship on or after 19 May 2005 or, in the absence of a contractual delivery date, the actual delivery of the equipment to the ship on or after 19 May 2005.

Installations which contain hydro-chlorofluorocarbons shall be prohibited (see also requirements of Regulation (EC) No 1005/2009 of the European parliament and of the Council of 16 September 2009 on substances that deplete the ozone layer):

- .3 on ships constructed on or after 1 January 2020; or
- .4 in the case of ships constructed before 1 January 2020, which have a contractual delivery date of the equipment to the ship on or after 1 January 2020 or, in the absence of a contractual delivery date, the actual delivery of the equipment to the ship on or after 1 January 2020.

**7.3.1.4** The substances referred to in 7.3.1, and equipment containing such substances, shall be delivered to appropriate reception facilities when removed from ships.

**7.3.1.5** Each ship subject to 7.2.2.1 shall maintain a list of equipment containing ozone depleting substances.

**7.3.1.6** Each ship subject to 7.2.2.1 which has rechargeable systems that contain ozone depleting substances shall maintain an *Ozone Depleting Substances Record Book*. This Record Book may form part of an existing log-book or electronic recording system as approved by the *Register*.

**7.3.1.7** Entries in the *Ozone Depleting Substances Record Book* shall be recorded in terms of mass [kg] of substance and shall be completed without delay on each occasion, in respect of the following:

- .1 recharge, full or partial, of equipment containing ozone depleting substances;
- .2 repair or maintenance of equipment containing ozone depleting substances;
- .3 discharge of ozone depleting substances to the atmosphere:
  - .3.1 deliberate; and
  - .3.2 non-deliberate;
- .4 discharge of ozone depleting substances to land-based reception facilities; and
- .5 supply of ozone depleting substances to the ship.

## 7.3.2 Nitrogen oxides (NOx)

### 7.3.2.1 Application

- .1 The item 7.3.2 shall apply to:
  - .1 each marine diesel engine with a power output of more than 130 kW installed on a ship; and

- .2 each marine diesel engine with a power output of more than 130 kW which undergoes a major conversion on or after 1 January 2000 except when demonstrated to the satisfaction of the *Register* that such engine is an identical replacement to the engine which it is replacing and is otherwise not covered under item 7.3.2.1-1.1.

- .2 The item 7.3.2 does not apply to:
  - .1 a marine diesel engine intended to be used solely for emergencies, or solely to power any device or equipment intended to be used solely for emergencies on the ship on which it is installed, or a marine diesel engine installed in lifeboats intended to be used solely for emergencies; and
  - .2 a marine diesel engine installed on a ship solely engaged in voyages within waters subject to the sovereignty or jurisdiction of the State the flag of which the ship is entitled to fly, provided that such engine is subject to an alternative NOx control measure established by the Administration.

- .3 Notwithstanding the provisions of 7.3.2.1-1, the Administration may provide an exclusion from the application of 7.3.2 for any marine diesel engine which is installed on a ship constructed, or for any marine diesel engine which undergoes a major conversion, before 19 May 2005, provided that the ship on which the engine is installed is solely engaged in voyages to ports or offshore terminals within the State the flag of which the ship is entitled to fly.

Note: The term *identical engine* in the sense of the term *identical replacement* is defined as the engine of equal design and model, rated power, rated speed, use, number of cylinders, fuel system type (including, if applicable, injection control software); and

- have the same NOx critical components and settings, for engines without EIAPP certificate, or
- belonging to the same Engine Group / Engine Family, for engines with EIAPP certificate.

In those instances where, at the time of updating the Supplement to the IAPP Certificate (to reflect that engine change) the replaced engine will not be available to be directly compared with the replacing engine, it is to be ensured that the necessary records in respect of the replaced engine are available in order that it can be confirmed that the replacing engine represents an identical engine.

For engines without EIAPP Certification there will not be the defining NO<sub>x</sub> critical component markings or setting values as usually given in the approved Technical File. Consequently in these instances the assessment of “the same NO<sub>x</sub> critical components and settings” shall be established on the basis that the following components and settings are the same:

- Fuel system (fuel pump model and injection timing, as well as injection nozzle model):

Charge air system (configuration and, if applicable, turbocharger model and auxiliary blower specification, as well as cooling medium, i.e. sea water or fresh water).

### 7.3.2.2 Major Conversion

.1 For the purpose of 7.3.2, *major conversion* means a modification on or after 1 January 2000 of a marine diesel engine that has not already been certified to the requirements set forth 7.3.2.3, 7.3.2.4 or 7.3.2.5-1.1 where:

- .1 the engine is replaced by a marine diesel engine or an additional marine diesel engine is installed, or
- .2 any substantial modification, as defined in the *NO<sub>x</sub> Technical Code 2008*, is made to the engine, or
- .3 the maximum continuous rating of the engine is increased by more than 10% compared to the maximum continuous rating of the original certification of the engine.

.2 For a major conversion involving the replacement of a marine diesel engine with a non-identical marine diesel engine (where non-identical engine is the one not meeting requirements of the Note in item 7.3.2.1), or the installation of an additional marine diesel engine, the requirements in 7.3.2 in force at the time of the replacement or addition of the engine shall apply. In the case of replacement engines only, if it is not possible for such a replacement engine to meet the requirements set forth in 7.3.2.5-1.1 (Tier III), then that replacement engine shall meet the requirements set forth in 7.3.2.4 (Tier II), taking into account guidelines in Res. MEPC.230(65).

.3 A marine diesel engine referred to in 7.3.2.2-1 or 7.3.2.2-2 shall meet the following requirements:

- .1 for ships constructed prior to 1 January 2000, the requirements set forth in 7.3.2.3 (Tier I) shall apply; and
- .2 for ships constructed on or after 1 January 2000, the requirements in force at the time the ship was constructed shall apply.

.4 In respect of marine diesel engines installed on or after 1 January 2000 but before 1 July 2010, *major conversion* means a modification of an engine where the engine is replaced (i.e. installed either as a direct replacement for an existing engine, or as an addition to the original engine to meet revised ship requirements) by a new engine built (i.e. engine that left the manufacturer’s works for the first time) on or after 1 January 2000.

#### 7.3.2.3 Tier I

Subject to 7.1.3, the operation of a marine diesel engine which is installed on a ship constructed on or after 1 January 2000 and prior to 1 January 2011 is prohibited, except when the emission of nitrogen oxides (calculated as the total weighted emission of NO<sub>2</sub>) from the engine is within the following limits:

- 17,0 g/kWh, when  $n < 130$  rpm
- $45 \cdot n^{-0.2}$  g/kWh, when  $130 \leq n < 2000$  rpm
- 9,8 g/kWh, when  $n \geq 2000$  rpm

where:

- $n$  – rated engine speed  
[crankshaft revolutions per minute].

#### 7.3.2.4 Tier II

Subject to 7.1.3, the operation of a marine diesel engine which is installed on a ship constructed on or after 1 January 2011 is prohibited, except when the emission of nitrogen oxides (calculated as the total weighted emission of NO<sub>2</sub>) from the engine is within the following limits:

- 14,4 g/kWh, when  $n < 130$  rpm
- $44 \cdot n^{-0.23}$  g/kWh, when  $130 \leq n < 2000$  rpm
- 7,7 g/kWh, when  $n \geq 2000$  rpm

where:

- $n$  – rated engine speed  
[crankshaft revolutions per minute].

#### 7.3.2.5 Tier III

.1 Subject to 7.1.3, the operation of a marine diesel engine which is installed on a ship in an emission control area is prohibited except:

when the emission of nitrogen oxides (calculated as the total weighted emission of NO<sub>2</sub>) from the engine is within the following limits:

- 3,4 g/kWh, when  $n < 130$  rpm
- $9 \cdot n^{-0.2}$  g/kWh, when  $130 \leq n < 2000$  rpm
- 7,7 g/kWh, when  $n \geq 2000$  rpm

where:

$n$  – rated engine speed  
[crankshaft revolutions per minute],  
when ship is operating in an emission control area, and is constructed on or after the date of adoption of such an emission control area, or a later date as may be specified in the amendment designating the NO<sub>x</sub> Tier III emission control area, whichever is later.

Ships constructed on or after 1 January 2016 and operating in the North American Emission

Control Area or the US Caribbean Sea Emission Control Area and ships constructed on or after 1st January 2021 and operating in the Baltic sea and North sea emission control area, are to comply with the emission limits in 7.3.2.5-1.1.

- .2 The standards set forth in 7.3.2.5-1.1 shall not apply to:
  - .1 a marine diesel engine installed on a ship with a length  $L$ , as defined in 2.1.2.26, less than 24 metres when it has been specifically designed, and is used solely, for recreational purposes; or
  - .2 a marine diesel engine installed on a ship with a combined nameplate diesel engine propulsion power of less than 750 kW if it is demonstrated, to the satisfaction of the *Register*, that the ship cannot comply with the standards set forth in 7.3.2.5-1.1 because of design or construction limitations of the ship, or
  - .3 a marine diesel engine installed on a ship constructed prior to 1 January 2021 of less than 500 gross tonnage, with a length  $L$ , as defined in 2.1.2.26 of 24 metres or over, when it has been specifically designed, and is used solely, for recreational purposes.
- .3 The tier and on/off status of marine diesel engines installed onboard a ship to which 7.3.2.5.1 applies which are certified to both Tier II and Tier III or which are certified to Tier II only shall be recorded in such logbook as prescribed by the Administration at entry into and exit from an emission control area designated under 7.3.2.6, or when the on/off status changes within such an area, together with date, time and position of the ship.

### 7.3.2.6 Emission Control Area

For the purpose of 7.3.2, an Emission Control Area shall be any sea area, including any port area, designated by the IMO in accordance with the criteria and procedures set forth in Appendix III to the IMO Res. MEPC.176(58).

### 7.3.2.7 Marine Diesel Engines Installed on a Ship Constructed Prior to 1st January 2000

- .1 Notwithstanding 7.3.2.1-1.1, a marine diesel engine with a power output of more than 5000 kW and a per cylinder displacement at or above 90 litres installed on a ship constructed on or after 1st January 1990 but prior to 1st January 2000 shall comply with the emission limits set forth in 7.3.2.7-4, provided that an Approved Method for that engine has been certified by a Administration of a Party to the Protocol of 1997 and notification of such certification has been sub-

mitted to the IMO by the certifying Administration. Compliance with this paragraph shall be demonstrated through one of the following:

- .1 installation of the certified Approved Method, as confirmed by a survey using the verification procedure specified in the Approved Method File, including appropriate notation on the ship's International Air Pollution Prevention Certificate of the presence of the Approved Method; or
- .2 certification of the engine confirming that it operates within the limits set forth in 7.3.2.3, 7.3.2.4 or 7.3.2.5-1.1 and an appropriate notation of the engine certification on the ship's International Air Pollution Prevention Certificate.
- .2 Subitem 7.3.2.7-1 shall apply no later than the first renewal survey that occurs 12 months or more after deposit of the notification in 7.3.2.7-1. If a shipowner of a ship on which an Approved Method is to be installed can demonstrate to the satisfaction of the *Register* that the Approved Method was not commercially available despite best efforts to obtain it, then that Approved Method shall be installed on the ship no later than the next annual survey of that ship which falls after the Approved Method is commercially available.
- .3 With regard to a ship with a marine diesel engine with a power output of more than 5000 kW and a per cylinder displacement at or above 90 litres installed on a ship constructed on or after 1st January 1990 but prior to 1st January 2000, the International Air Pollution Prevention Certificate shall, for a marine diesel engine to which 7.3.2.7-1 applies, indicate that either an Approved Method has been applied pursuant to 7.3.2.7-1.1 or the engine has been certified pursuant to 7.3.2.7-1.2 or that an Approved Method is not applicable or is not yet commercially available as described in 7.3.2.7-2.
- .4 Subject to 7.1.3, the operation of a marine diesel engine described in 7.3.2.7-1 is prohibited, except when the emission of nitrogen oxides (calculated as the total weighted emission of  $\text{NO}_2$ ) from the engine is within the following limits:
 
$$17,0 \text{ g/kWh, when } n < 130 \text{ rpm}$$

$$45 \cdot n^{-0,2} \text{ g/kWh, when } 130 \leq n < 2000 \text{ rpm}$$

$$9,8 \text{ g/kWh, when } n \geq 2000 \text{ rpm}$$
 where:  
 $n$  – rated engine speed  
 [crankshaft revolutions per minute].

- .5 Certification of an Approved Method shall be in accordance with 7.4.13 and shall include verification:
- .1 by the designer of the base marine diesel engine to which the Approved Method applies that the calculated effect of the Approved Method will not decrease engine rating by more than 1,0%, increase fuel consumption by more than 2,0% as measured according to the appropriate test cycle set forth in 7.4.9, or adversely affect engine durability or reliability; and
  - .2 that the cost of the Approved Method is not excessive, which is determined by a comparison of the amount of NO<sub>x</sub> reduced by the Approved Method to achieve the standard set forth in 7.3.2.7-4 and the cost of purchasing and installing such Approved Method.

*Note:* The cost of an Approved Method  $C_e$  shall not exceed 375 Special Drawing Rights/metric ton NO<sub>x</sub> calculated in accordance with the Cost-Effectiveness formula below:

$$C_e = \frac{\text{Cost of approved method} \cdot 10^6}{P[\text{kW}] \cdot 0,768 \cdot 6000[\text{h/year}] \cdot 5[\text{years}] \cdot \Delta NO_x[\text{g/kWh}]}$$

### 7.3.2.8 Certification

The *NO<sub>x</sub> Technical Code 2008* shall be applied in the certification, testing, and measurement procedures for the standards set forth in 7.3.2.

**7.3.2.9** The procedures for determining NO<sub>x</sub> emissions set out in the *NO<sub>x</sub> Technical Code 2008* are intended to be representative of the normal operation of the engine. Defeat devices and irrational emission control strategies undermine this intention and shall not be allowed. Requirements of 7.3.2 shall not prevent the use of auxiliary control devices that are used to protect the engine and/or its ancillary equipment against operating conditions that could result in damage or failure or that are used to facilitate the starting of the engine.

## 7.3.3 Sulphur Oxides (SO<sub>x</sub>) and Particulate Matter

### General Requirements

**7.3.3.1** The sulphur content of any fuel oil used on board ships shall not exceed the following limits:

- .1 4,50% m/m prior to 1st January 2012;
- .2 3,50% m/m on and after 1st January 2012; and
- .3 0,50% m/m on and after 1st January 2020.

### 7.3.3.2

- .1 The worldwide average sulphur content of residual fuel oil supplied for use on board ships shall be monitored taking into account guidelines developed by the IMO (see resolution MEPC.192(61) *Guidelines for Monitoring the World-wide Average Sulphur Content of Fuel Oils Supplied for*

*Use On Board Ships*, as amended by Res.MEPC.273(69)).

- .2 **Intentionally blank.**
- .3 On ships at berth in EU ports, except on ships with published timetables which are due to be at berth for less than two hours, fuel oils with a sulphur content exceeding 0,1% by mass shall not be used. In that respect, it is necessary to complete fuel change-over operation as soon as possible after arrival at berth and as late as possible before departure. This shall not apply to ships which at berth in EU ports switch off all engines and use shoreside electricity.

### Requirements within Emission Control Areas

**7.3.3.3** For the purpose of 7.3.3 Emission Control Areas shall include:

- .1 the Baltic Sea area as defined in MARPOL 73/78 Convention, Annex I, regulation 1.11.2, the North Sea as defined in MARPOL 73/78 Convention, Annex V, regulation 5(1)(f); and
- .2 any other sea area, including port areas, designated by the IMO in accordance with criteria and procedures set forth in Appendix III to the IMO Res. MEPC.176(58).

**7.3.3.4** While ships are operating within an Emission Control Area, the sulphur content of fuel oil used on board ships shall not exceed the following limits:

- .1 1,50% m/m prior to 1 July 2010;
- .2 1,00% m/m on and after 1 July 2010; and
- .3 0,10% m/m on and after 1 January 2015.

**7.3.3.5** The sulphur content of fuel oil referred to in 7.3.3.1 and 7.3.3.4 shall be documented by its supplier as required by 7.3.6.

**7.3.3.6** Those ships using separate fuel oils to comply with 7.3.3.4 and entering or leaving an Emission Control Area set forth in 7.3.3.3 shall carry a written procedure showing how the fuel oil change-over is to be done, allowing sufficient time for the fuel oil service system to be fully flushed of all fuel oils exceeding the applicable sulphur content specified in 7.3.3.4 prior to entry into an Emission Control Area. The volume of low sulphur fuel oils in each tank as well as the date, time, and position of the ship when any fuel-oil-change-over operation is completed prior to the entry into an Emission Control Area or commenced after exit from such an area, shall be recorded in such log-book as prescribed by the Administration.

**7.3.3.7** During the first twelve months immediately following an amendment designating a specific Emission Control Area under 7.3.3.3-2, ships operating in that Emission Control Area are exempt from the requirements in 7.3.3.4 and 7.3.3.6 and from the requirements of 7.3.3.5 insofar as they relate to 7.3.3.4.

### 7.3.4 Volatile Organic Compounds (VOCs)

**7.3.4.1** If the emissions of VOCs from a tanker are to be regulated in a port or ports or a terminal or terminals under the jurisdiction of a Party to the Protocol of 1997, 7.3.4.2 and 7.3.4.3 are applied.

**7.3.4.2** A tanker to which 7.3.4.1 applies shall be provided with a vapour emission collection system approved by the *Register* taking into account the safety standards for such systems developed by the IMO (MSC/Circ.585 *Standards for vapour emission control systems*), and shall use this system during the loading of relevant cargoes.

**7.3.4.3** A tanker carrying crude oil shall have on board and implement a VOC Management Plan approved by the *Register*. Such a plan shall be prepared taking into account the guidelines in the IMO Res. MEPC.185(59) and the circular MEPC.1/Circ. 680. The plan shall be specific to each ship and shall at least:

- .1 provide written procedures for minimising VOC emissions during the loading, sea passage and discharge of cargo;
- .2 give consideration to the additional VOC generated by crude oil washing;
- .3 identify a person responsible for implementing the plan; and
- .4 for ships on international voyages, be written in the working language of the master and officers and, if the working language of the master and officers is not English, French, or Spanish, include a translation into one of these languages.

### 7.3.5 Shipboard incineration

**7.3.5.1** Except as provided in 7.3.5.4, shipboard incineration shall be allowed only in a shipboard incinerator.

**7.3.5.2** Shipboard incineration of the following substances shall be prohibited:

- .1 residues of cargoes subject to MARPOL 73/78 Convention, Annex I, II or III or related contaminated packing materials;
- .2 polychlorinated biphenyls (PCBs);
- .3 garbage, as defined by MARPOL 73/78 Convention, Annex V, containing more than traces of heavy metals;
- .4 refined petroleum products containing halogen compounds;
- .5 sewage sludge and sludge oil either of which are not generated on board the ship; and
- .6 exhaust gas cleaning system residues.

**7.3.5.3** Shipboard incineration of polyvinyl chlorides (PVCs) shall be prohibited, except in shipboard incinerator for which an IMO Type Approval Certificate, in accordance with IMO Res. MEPC.59(33) or IMO Res. MEPC.76(40), has been issued.

**7.3.5.4** Shipboard incineration of sewage sludge and sludge oil generated during normal operation of a ship may also take place in the main or auxiliary power plant or boilers, but in those cases, shall not take place inside ports, harbours and estuaries.

**7.3.5.5** Nothing in 7.3.5 either:

- .1 affects the prohibition in, or other requirements of, the *Convention on the Prevention of Marine Pollution by Dumping of Wastes and Other Matter*, 1972, as amended, and the *1996 Protocol* thereto, or
- .2 precludes the development, installation and operation of alternative design shipboard thermal waste treatment devices that meet or exceed the requirements of 7.3.5.

**7.3.5.6** Each incinerator on a ship constructed on or after 1 January 2000 shall meet the requirements contained in appendix IV to the resolution MEPC.176(58). Each incinerator subject to this sub-item shall be approved by the *Register* taking into account the standard specification for shipboard incinerators developed by the IMO (refer to IMO Res. MEPC.76(40) *Standard specification for shipboard incinerators*); or

**7.3.5.7** Incinerators installed in accordance with the requirements of 7.3.5.6-1 shall be provided with a manufacturer's operating manual which is to be retained with the unit and which shall specify how to operate the incinerator within the limits described in paragraph 2 of appendix IV to the IMO Res. MEPC.176(58).

**7.3.5.8** Personnel responsible for the operation of an incinerator installed in accordance with the requirements of 7.3.5.6-1 shall be trained to implement the guidance provided in the manufacturer's operating manual as required by 7.3.5.7.

**7.3.5.9** For incinerators installed in accordance with the requirements of 7.3.5.6-1 the combustion chamber gas outlet temperature shall be monitored at all times the unit is in operation. Where that incinerator is of the continuous-feed type, waste shall not be fed into the unit when the combustion chamber gas outlet temperature is below 850°C. Where that incinerator is of the batch-loaded type, the unit shall be designed so that the combustion chamber gas outlet temperature shall reach 600°C within five minutes after start-up and will thereafter stabilise at a temperature not less than 850°C.

### 7.3.6 Fuel oil quality

**7.3.6.1** Fuel oil for combustion purposes delivered to and used on board ships to which this Chapter applies shall meet the following requirements:

- .1 except as provided in 7.3.6.1-.2:
  - .1 the fuel oil shall be blends of hydrocarbons derived from petroleum refining. This shall not preclude the incorporation of small amounts of additives intended to improve some aspects of performance;
  - .2 the fuel oil shall be free from inorganic acid; and
  - .3 the fuel oil shall not include any added substance or chemical waste which:

- .1 jeopardises the safety of ships or adversely affects the performance of the machinery, or
  - .2 is harmful to personnel, or
  - .3 contributes overall to additional air pollution.
- .2 fuel oil for combustion purposes derived by methods other than petroleum refining shall not:
- .1 exceed the applicable sulphur content set forth in 7.3.3;
  - .2 cause an engine to exceed the applicable NO<sub>x</sub> emission limit set forth in paragraphs 7.3.2.3, 7.3.2.4, 7.3.2.5-.1.1 and 7.3.2.7-4;
  - .3 contain inorganic acid; or
  - .4 jeopardise the safety of ships or adversely affect the performance of the machinery, or
  - .5 be harmful to personnel, or
  - .6 contribute overall to additional air pollution.

**7.3.6.2** Sub-items 7.3.6.3 and 7.3.6.4 are applicable to all ships of 400 GT or above.

Item 7.3.6 does not apply to coal in its solid form or nuclear fuels.

Sub-items 7.3.6.3, 7.3.6.4 and 7.3.6.5 do not apply to gas fuels such as Liquefied Natural Gas, Compressed Natural Gas or Liquefied Petroleum Gas. The sulphur content of gas fuels delivered to a ship specifically for combustion purposes on board that ship shall be documented by the supplier.

**7.3.6.3** For each ship subject to 7.2.1 and 7.2.2, details of fuel oil for combustion purposes delivered to and used on board shall be recorded by means of a bunker delivery note which shall contain at least the information specified in appendix V to the IMO Res. MEPC.176(58).

**7.3.6.4** The bunker delivery note shall be kept on board the ship in such a place as to be readily available for inspection at all reasonable times. It shall be retained for a period of three years after the fuel oil has been delivered on board.

**7.3.6.5** The bunker delivery note shall be accompanied by a representative sample of the fuel oil delivered taking into account guidelines developed by the IMO (refer to IMO Res. MEPC.96(47) *Guidelines for the Sampling of Fuel Oil for Determination of Compliance with Annex VI of MARPOL 73/78*). The sample is to be sealed and signed by the supplier's representative and the master or officer in charge of the bunker operation on completion of bunkering operations. The sample is to be retained under the ship's control until the fuel oil is substantially consumed, but in any case for a period of not less than 12 months from the time of delivery.

## 7.4 REQUIREMENTS OF NO<sub>x</sub> TECHNICAL CODE 2008

### 7.4.1 Introduction and purpose

**7.4.1.1** As general background information, the precursors to the formation of nitrogen oxides during the combustion process are nitrogen and oxygen. Together these compounds comprise 99% of the engine intake air. Oxygen will be consumed during the combustion process, with the amount of excess oxygen available being a function of the air/fuel ratio which the engine is operating under.

The nitrogen remains largely unreacted in the combustion process; however, a small percentage will be oxidised to form various oxides of nitrogen. The nitrogen oxides (NO<sub>x</sub>) which can be formed include nitric oxide (NO) and nitrogen dioxide (NO<sub>2</sub>), while the amounts are primarily a function of flame or combustion temperature and, if present, the amount of organic nitrogen available from the fuel. NO<sub>x</sub> formation is also a function of the time the nitrogen and the excess oxygen are exposed to the high temperatures associated with the diesel engine's combustion process. In other words, the higher the combustion temperature (e.g., high-peak pressure, high-compression ratio, high rate of fuel delivery, etc.), the greater the amount of NO<sub>x</sub> formation. A slow-speed diesel engine, in general, tends to have more NO<sub>x</sub> formation than a high speed engine.

NO<sub>x</sub> has an adverse effect on the environment causing acidification, formation of tropospheric ozone, nutrient enrichment and contributes to adverse health effects globally.

**7.4.1.2** The purpose of *Technical Code on Control of Emission of Nitrogen Oxides from Marine Diesel Engines*, hereunder referred to as the *NO<sub>x</sub> Technical Code 2008*, is to provide mandatory procedures for the testing, survey and certification of marine diesel engines which will enable engine manufacturers, shipowners and Administrations to ensure that all applicable marine diesel engines comply with the relevant limiting emission values of NO<sub>x</sub> as specified 7.3.2.

The difficulties of establishing with precision, the actual weighted average NO<sub>x</sub> emission of marine diesel engines in service on ships have been recognised in formulating a simple, practical set of requirements in which the means to ensure compliance with the allowable NO<sub>x</sub> emissions are defined.

**7.4.1.3** Administrations are encouraged to assess the emissions performance of marine propulsion and auxiliary diesel engines on a test bed, where accurate tests can be carried out under properly controlled conditions.

Establishing compliance with 7.3.2 at this initial stage is an essential feature of the *NO<sub>x</sub> Technical Code 2008*. Subsequent testing on board the ship may inevitably be limited in scope and accuracy. Its purpose shall be to infer or deduce the emission performance and to confirm that engines are installed, operated and maintained in accordance with the manufacturer's specifications and that any adjustments or modifications do not detract from the emissions performance established by initial testing and certification by the manufacturer.

## 7.4.2 Application

**7.4.2.1** *NOx Technical Code 2008* applies to all marine diesel engines with a power output of more than 130 kW which are installed, or are designed and intended for installation, on board any ship subject to Chapter 7 and to which 7.3.2 applies. Regarding the requirements for survey and certification under 7.2.1, this Code addresses only those requirements applicable to an engine's compliance with the NOx emission limits.

**7.4.2.2** For the purpose of the application of the *NOx Technical Code 2008*, Administrations are entitled to delegate all functions required of an Administration by this Code to a Recognised Organisation (RO), i.e. an organisation authorised to act on behalf of the Administration (refer to the IMO resolutions A.739(18) *Guidelines for the Authorisation of Organisations Acting on Behalf of Administrations* and A.789(19) *Specifications on the Survey and Certification Functions of Recognised Organisations Acting on Behalf of the Administration*). In every case, the Administration assumes full responsibility for the survey and certificate.

**7.4.2.3** For the purpose of the *NOx Technical Code 2008*, an engine shall be considered to be operated in compliance with the applicable NOx limit of 7.3.2 if it can be demonstrated that the weighted NOx emissions from the engine are within those limits at the initial certification, annual, intermediate and renewal surveys and such other surveys as are required.

## 7.4.3 Definitions

**7.4.3.1 Nitrogen oxide (NOx) emissions** – means the total emission of nitrogen oxides, calculated as the total weighted emission of NO<sub>2</sub> and determined using the relevant test cycles and measurement methods as specified in *NOx Technical Code 2008*.

**7.4.3.2 Substantial modification** – of a marine diesel engine means:

- 1 For engines installed on ships constructed on or after 1 January 2000 – any modification to an engine that could potentially cause the engine to exceed the emission standards set out in 7.3.2. Routine replacement of engine components by parts specified in the *Technical File* that do not alter emission characteristics shall not be considered a substantial modification regardless of whether one part or many parts are replaced.
- 2 For engines installed on ships constructed before 1 January 2000 – any modification made to an engine which increases its existing emission characteristics established by the *Simplified measurement method* as described in 7.4.12.3 in excess of the allowances set out in 7.4.12.3-4.10. These changes include, but are not limited to, changes in its operations or in its technical parameters (e.g., changing camshafts, fuel injection systems, air systems, combustion chamber configuration, or timing calibration of the engine). The in-

stallation of a certified Approved Method pursuant to 7.3.2.7-1.1 or certification pursuant to 7.3.2.7-1.2 is not considered to be a substantial modification for the purpose of the application of 7.3.2.2.

**7.4.3.3 Components** – are those interchangeable parts which influence the NOx emissions performance, identified by their design/parts number.

**7.4.3.4 Setting** – means adjustment of an adjustable feature influencing the NOx emissions performance of an engine.

**7.4.3.5 Operating values** – are engine data, like cylinder peak pressure, exhaust gas temperature, etc., from the engine log which are related to the NOx emission performance. These data are load-dependent.

**7.4.3.6 EIAPP Certificate** – is the *Engine International Air Pollution Prevention Certificate* which relates to NOx emissions.

**7.4.3.7 IAPP Certificate** – is the International Air Pollution Prevention Certificate.

**7.4.3.8 Administration** – has the same meaning as in article 2, subparagraph (5) of MARPOL 73.

**7.4.3.9 On-board NOx verification procedures** – mean a procedure, which may include an equipment requirement, to be used on board at initial certification survey or at the renewal, annual or intermediate surveys, as required, to verify compliance with any of the requirements of *NOx Technical Code 2008*, as specified by the engine manufacturer and approved by the Administration.

**7.4.3.10 Marine diesel engine** – means any reciprocating internal-combustion engine operating on liquid or dual fuel, to which 7.3.2 applies, including booster/compound systems if applied.

A gas-fuelled engine installed on a ship constructed on or after 1st March 2016 or a gas-fuelled additional or non-identical replacement engine installed on or after that date is also considered as a marine diesel engine.

Where an engine is intended to be operated normally in the gas mode, i.e. with the gas fuel as the main fuel and with liquid fuel as the pilot or balance fuel, the requirements of 7.3.2 have to be met only for this operation mode. Operation on pure liquid fuel resulting from restricted gas supply in cases of failures shall be exempted for the voyage to the next appropriate port for the repair of the failure.

**7.4.3.11 Rated power** – means the maximum continuous rated power output as specified on the nameplate and in the *Technical File* of the marine diesel engine to which 7.3.2 and the *NOx Technical Code 2008* apply.

**7.4.3.12 Rated speed** – is the crankshaft revolutions per minute at which the rated power occurs as specified on the nameplate and in the *Technical File* of the marine diesel engine.

**7.4.3.13 Brake power** – is the observed power measured at the crankshaft or its equivalent, the engine being equipped only with the standard auxiliaries necessary for its operation on the test-bed.

**7.4.3.14 On-board conditions** – mean that an engine is:



- .1 installed on board and coupled with the actual equipment which is driven by the engine; and
- .2 under operation to perform the purpose of the equipment.

**7.4.3.15 Technical File** – is a record containing all details of parameters, including components and settings of an engine, which may influence the NO<sub>x</sub> emission of the engine, in accordance with 7.4.7.

**7.4.3.16 Record book of engine parameters** – is the document used in connection with the *Engine Parameter Check Method* for recording all parameter changes, including components and engine settings, which may influence NO<sub>x</sub> emission of the engine.

**7.4.3.17 Approved Method** – is a method for a particular engine, or a range of engines, which, when applied to the engine, will ensure that the engine complies with the applicable NO<sub>x</sub> limit as detailed in 7.3.2.7.

**7.4.3.18 Existing Engine** – is an engine which is subject to 7.3.2.7.

**7.4.3.19 Approved Method File** – is a document which describes an Approved Method and its means of survey

#### 7.4.4 Surveys and certification in general

**7.4.4.1** Each marine diesel engine specified in 7.4.4, except as otherwise permitted by the *NO<sub>x</sub> Technical Code 2008*, shall be subject to the following surveys:

- .1 A **pre-certification survey** – which shall be such as to ensure that the engine, as designed and equipped, complies with the NO<sub>x</sub> emission limits contained in 7.3.2. If this survey confirms compliance, the Administration shall issue an *Engine International Air Pollution Prevention (EIAPP) Certificate*.
- .2 An **initial certification survey** – which shall be conducted on board a ship after the engine is installed but before it is placed in service. This survey shall be such as to ensure that the engine, as installed on board the ship, including any modifications and/or adjustments since the pre-certification, if applicable, complies with the NO<sub>x</sub> emission limits contained in 7.3.2. This survey, as part of the ship's initial survey, may lead to either the issuance of a ship's initial *International Air Pollution Prevention (IAPP) Certificate* or an amendment of a ship's valid *IAPP Certificate* reflecting the installation of a new engine.
- .3 **Renewal, annual and intermediate surveys** – which shall be conducted as part of a ship's surveys required by 7.2.1, to ensure the engine continues to fully comply with the provisions of the *NO<sub>x</sub> Technical Code 2008*.
- .4 An **initial engine's certification survey** – which shall be conducted on board a ship every time a major conversion as de-

finied in 7.3.2.2 is made to an engine to ensure that the engine complies with the NO<sub>x</sub> emission limits contained in 7.3.2. This will result in the issue, if applicable, of an EIAPP Certificate and the amendment of the IAPP Certificate.

**7.4.4.2** To comply with the survey and certification requirements described in 7.4.4.1, there are methods included in the *NO<sub>x</sub> Technical Code 2008* from which the engine manufacturer, ship builder or ship owner, as applicable, can choose to measure, calculate test or verify an engine for its NO<sub>x</sub> emissions, as follows:

- .1 **Test-bed testing** for the pre-certification survey in accordance with 7.4.11;
- .2 **On-board testing** for an engine not pre-certified, for a combined pre-certification and initial certification survey in accordance with the full test-bed requirements of 7.4.11;
- .3 **On-board engine parameter check method**, using the component data, engine settings and engine performance data as specified in the *Technical File*, for confirmation of compliance at initial, renewal, annual and intermediate surveys for pre-certified engines or engines that have undergone modifications or adjustments to the NO<sub>x</sub> critical components, settings and operating values, since they were last surveyed, in accordance with 7.4.12.2;
- .4 **On-board simplified measurement method** for confirmation of compliance at renewal, annual and intermediate surveys or confirmation of pre-certified engines for initial certification surveys, in accordance with 7.4.12.3; or
- .5 **On-board direct measurement and monitoring** for confirmation of compliance at renewal, annual and intermediate surveys only, in accordance with 7.4.12.4.

#### 7.4.5 Procedures for pre-certification of an engine

**7.4.5.1** Prior to installation on board, every marine diesel engine, except as allowed by 7.4.5.2 and 7.4.5.4, shall:

- .1 be adjusted to meet the applicable NO<sub>x</sub> emission limits;
- .2 have its NO<sub>x</sub> emissions measured on a test-bed in accordance with the procedures specified in 7.4.11; and
- .3 be pre-certified by the Administration, as documented by issuance of an EIAPP Certificate.

**7.4.5.2** For the pre-certification of serially manufactured engines, depending on the approval of the Administration, the *Engine Family* or the *Engine Group* concept may be applied (see 7.4.10). In such a case, the testing specified in 7.4.5.1-.2 is required only for the *Parent Engine(s)* of an Engine Family or Engine Group.

**7.4.5.3** The method of obtaining pre-certification for an engine is for the Administration to:

- .1 certify a test of the engine on a test-bed;
- .2 verify that all engines tested, including, if applicable, those to be delivered within an Engine Family or the Engine Group, meet the NOx limits; and
- .3 if applicable, verify that the selected Parent Engine(s) is representative of an Engine Family or the Engine Group.

**7.4.5.4**

- .1 There are engines which, due to their size, construction and delivery schedule, cannot be pre-certified on a test-bed. In such cases, the engine manufacturer, ship owner or ship builder shall make application to the Administration requesting an on-board test (see 7.4.4.2-.2). The applicant must demonstrate to the Administration that the on-board test fully meets all of the requirements of a test-bed procedure as specified in 7.4.11. In no case shall an allowance be granted for possible deviations of measurements if an initial survey is carried out on board a ship without any valid pre-certification test. For engines undergoing an onboard certification test, in order to be issued with an EIAPP Certificate, the same procedures apply as if the engine had been pre-certified on a test-bed, subject to the limitations given in paragraph 7.4.5.5/.2.
- .2 This pre-certification survey procedure may be accepted for an Individual Engine or for an Engine Group represented by the Parent Engine only, but it shall not be accepted for an Engine Family certification.

**7.4.5.5 NOx reducing devices**

- .1 Where a NOx reducing device is to be included within the EIAPP certification, it must be recognised as a component of the engine and its presence shall be recorded in the engine's Technical File. The engine shall be tested, at the pre-certification test, with the NOx reducing device fitted, unless, due to technical and practical reasons, the combined testing is not appropriate and the procedures specified in 7.4.5.4/.1 cannot be applied, subject to approval by the Administration. In the latter case, the applicable test procedure shall be performed and the combined engine/NOx-reducing device shall be approved and pre-certified by the Administration, taking into account International Maritime Organization resolution **MEPC.291(71) 2017** *Guidelines addressing additional aspects to the NOx Technical Code 2008 with regard to particular requirements related to marine diesel en-*

*gines fitted with selective catalytic reduction (SCR) systems.*

However, this pre-certification is subject to the limitations given in 7.4.5.4/.2.

Note 1: The gaseous emissions calculation method given in IMO Res. **MEPC.291(71)** for Scheme A applies to both Scheme A and Scheme B certification of marine diesel engines fitted with selective catalytic reduction (SCR) systems.

Note 2: For guidelines regarding particular requirements related to marine diesel engines fitted with SCR systems see IACS UI MPC 108 to MPC 123.

- .2 In those cases where a NOx reducing device has been fitted due to failure to meet the required emission value at the pre-certification test, in order to receive an EIAPP Certificate for this assembly, the engine, including the reducing device, as installed, must be re-tested to show compliance with the applicable NOx emission limit. However, in this case, the assembly may be re-tested in accordance with the Simplified Measurement method in accordance with 7.4.12.3. In no case shall the allowances given in Chapter 6.3.11 of the *NOx Technical Code 2008* be granted.
- .3 Where, in accordance with 7.4.5.5-.2, the effectiveness of the NOx reducing device is verified by use of the Simplified Measurement method, that test report shall be added as an adjunct to the pre-certification test report which demonstrated the failure of the engine alone to meet the required emission value. Both test reports shall be submitted to the Administration, and test report data, as detailed in 7.4.7.1-.5, covering both tests shall be included in the engine's Technical File.
- .4 The Simplified Measurement method used as part of the process to demonstrate compliance in accordance with 7.4.5.5-.2 may only be accepted in respect of the engine and NOx reducing device on which its effectiveness was demonstrated, and it shall not be accepted for Engine Family or Engine Group certification.
- .5 In both cases as given in 7.4.5.5-.1 and 7.4.5.5-.2, the NOx reducing device shall be included on the EIAPP Certificate together with the emission value obtained with the device in operation and all other records as required by the Administration. The engine's Technical File shall also contain onboard NOx verification procedures for the device to ensure it is operating correctly.

- .6 Notwithstanding 7.4.5.5-.3 and 7.4.5.5-.4, a NO<sub>x</sub> reducing device may be approved by the Administration taking into account guidelines to be developed by the IMO.

**7.4.5.6** Where, due to changes of component design, it is necessary to establish a new Engine Family or Engine Group but there is no available Parent Engine the engine builder may apply to the Administration to use the previously obtained Parent Engine test data modified at each specific mode of the applicable test cycle so as to allow for the resulting changes in NO<sub>x</sub> emission values. In such cases, the engine used to determine the modification emission data shall correspond in accordance with 7.4.10.12-1 to the previously used Parent Engine. Where more than one component is to be changed the combined effect resulting from those changes is to be demonstrated by a single set of test results.

**7.4.5.7** For pre-certification of engines within an Engine Family or Engine Group, an EIAPP Certificate shall be issued in accordance with procedures established by the Administration to the Parent Engine(s) and to every Member Engine produced under this certification to accompany the engines throughout their life whilst installed on ships under the authority of that Administration.

**7.4.5.8 Issue of certification by the Administration of the country in which the engine is built**

- .1 When an engine is manufactured outside the country of the Administration of the ship on which it will be installed, the Administration of the ship may request the Administration of the country in which the engine is manufactured to survey the engine. Upon satisfaction that the applicable requirements of 7.3.2 are complied with pursuant to the *NO<sub>x</sub> Technical Code 2008*, the Administration of the country in which the engine is manufactured shall issue or authorise the issuance of the EIAPP Certificate.
- .2 A copy of the certificate(s) and a copy of the survey report shall be transmitted as soon as possible to the requesting Administration.
- .3 A certificate so issued shall contain a statement to the effect that it has been issued at the request of the Administration.

**7.4.5.9** Guidance in respect of the pre-certification survey and certification of marine diesel engines, as described in 7.4.4, is given in the relevant flowchart (see 7.4.14.1) of the *NO<sub>x</sub> Technical Code 2008*. Where discrepancies exist, the text of 7.4.4 takes precedence.

**7.4.6 Procedures for certification of an engine**

**7.4.6.1** For those engines which have not been adjusted or modified relative to the original specification of the manufacturer, the provision of a valid EIAPP Certificate should suffice to demonstrate compliance with the applicable NO<sub>x</sub> limits.

**7.4.6.2** After installation on board, it shall be determined to what extent an engine has been subjected to further adjustments and/or modifications which could affect the NO<sub>x</sub>

emission. Therefore, the engine, after installation on board, but prior to issuance of the IAPP Certificate, shall be inspected for modifications and be approved using the on-board NO<sub>x</sub> verification procedures described in 7.4.7.3.

**7.4.6.3** There are engines which, after pre-certification, need final adjustment or modification for performance. In such a case, the Engine Group concept could be used to ensure that the engine still complies with the applicable limit.

**7.4.6.4** Every marine diesel engine installed on board a ship shall be provided with a Technical File. The Technical File shall be prepared by the applicant for engine certification and approved by the Administration, and is required to accompany an engine throughout its life on board ships. The Technical File shall contain the information as specified in 7.4.7.1.

**7.4.6.5** Where a NO<sub>x</sub> reducing device is installed and needed to comply with the NO<sub>x</sub> limits, one of the options providing a ready means for verifying compliance with 7.3.2 is the Direct Measurement and Monitoring Method in accordance with 7.4.12.4. However, depending on the technical possibilities of the device used, subject to the approval of the Administration, other relevant parameters could be monitored.

**7.4.6.6** Where, for the purpose of achieving NO<sub>x</sub> compliance, an additional substance is introduced, such as ammonia, urea, steam, water, fuel additives, etc., a means of monitoring the consumption of such substance shall be provided. The Technical File shall provide sufficient information to allow a ready means of demonstrating that the consumption of such additional substances is consistent with achieving compliance with the applicable NO<sub>x</sub> limit.

**7.4.6.7** Where the Engine Parameter Check method in accordance with 7.4.12.2 is used to verify compliance, if any adjustments or modifications are made to an engine after its pre-certification, a full record of such adjustments or modifications shall be recorded in the engine's Record Book of Engine Parameters.

**7.4.6.8** If all of the engines installed on board are verified to remain within the parameters, components, and adjustable features recorded in the Technical File, the engines should be accepted as performing within the applicable NO<sub>x</sub> limit specified in 7.3.2. In this case, provided all other applicable requirements of 7.1 to 7.3 are complied with, an IAPP Certificate should then be issued to the ship.

**7.4.6.9** If any adjustment or modification is made which is outside the approved limits documented in the Technical File, the IAPP Certificate may be issued only if the overall NO<sub>x</sub> emission performance is verified to be within the required limits by:

- .1 onboard Simplified Measurement in accordance with 7.4.12.3; or,
- .2 reference to the test-bed testing for the relevant Engine Group approval showing that the adjustments or modifications do not exceed the applicable NO<sub>x</sub> emission limit.

At surveys after the initial engine survey, the Direct Measurement and Monitoring method in accordance with Chapter 6.4 of the *NO<sub>x</sub> Technical Code 2008*, as approved by the Administration, may alternatively be used.

**7.4.6.10** The Administration may, at its own discretion, abbreviate or reduce all parts of the survey on board, in accordance with the *NOx Technical Code 2008* to an engine which has been issued an EIAPP Certificate. However, the entire survey on board must be completed for at least one cylinder and/or one engine in an Engine Family or Engine Group, if applicable, and the abbreviation may be made only if all the other cylinders and/or engines are expected to perform in the same manner as the surveyed engine and/or cylinder. As an alternative to the examination of fitted components, the Administration may conduct that part of the survey on spare parts carried on board provided they are representative of the components fitted.

**7.4.6.11** Guidance in respect of the survey and certification of marine diesel engines at initial, renewal, annual and intermediate surveys, as described in 7.4.6, is given in the relevant flowchart (see 7.4.14.1) of the *NOx Technical Code 2008*. Where discrepancies exist, the text of 7.4.6 takes precedence.

#### **7.4.7 Technical file and on-board NOx verification procedures**

**7.4.7.1** To enable the Administration to perform the engine surveys described in 7.4.4, the Technical File required by 7.4.6.4 shall, at a minimum, contain the following information:

- .1 Identification of those components, settings and operating values of the engine which influence its NOx emissions including any NOx reducing device or system;
- .2 Identification of the full range of allowable adjustments or alternatives for the components of the engine;
- .3 Full record of the relevant engine's performance, including the engine's rated speed and rated power;
- .4 a system of on-board NOx verification procedures to verify compliance with the NOx emission limits during on-board verification surveys in accordance with 7.4.12;
- .5 A copy of the relevant Parent Engine test data, as given in section 2 of appendix 5 of the *NOx Technical Code 2008*;
- .6 If applicable, the designation and restrictions for an engine which is an engine within an Engine Family or Engine Group;
- .7 specifications of those spare parts / components which, when used in the engine, according to those specifications, will result in continued compliance of the engine with the NOx emission limit; and
- .8 the EIAPP Certificate, as applicable.

**7.4.7.2** As a general principle, onboard NOx verification procedures shall enable a surveyor to easily determine if an engine has remained in compliance with the applicable requirements of 7.3.2. At the same time, it shall not be so burdensome as to unduly delay the ship or to require in-depth knowledge of the characteristics of a particular engine or specialist measuring devices not available on board.

**7.4.7.3** The onboard NOx verification procedure shall be one of the following methods:

- .1 Engine Parameter Check method in accordance with 7.4.12.2 to verify that an engine's component, setting and operating values have not deviated from the specifications in the engine's Technical File;
- .2 Simplified Measurement method in accordance with 7.4.12.3; or
- .3 Direct Measurement and Monitoring method in accordance with 7.4.12.4.

**7.4.7.4** When considering which onboard NOx verification procedures should be included in an engine's Technical File to verify whether an engine complies with the applicable NOx emission limit during the required onboard verification surveys, other than at an engine's initial onboard survey, any of the three onboard NOx verification procedures as specified in 7.4.12.1 may be applied. However, the procedures associated with the method applied are to be approved by the Administration. If the method differs from the verification procedure method specified in the Technical File as originally approved, the procedure of the method needs to be either added as an amendment to the Technical File or appended as an alternative to the procedure given in the Technical File. Thereafter the shipowner may choose which of the methods approved in the Technical File is to be used to demonstrate compliance.

**7.4.7.5** In addition to the method specified by the engine manufacturer and given in the Technical File, as approved by the Administration for the initial certification in the engine, the shipowner shall have the option of direct measurement of NOx emissions in accordance with 7.4.12.4.

Such data may take the form of spot checks logged with other engine operating data on a regular basis and over the full range of engine operation or may result from continuous monitoring and data storage. Data must be current (taken within the last 30 days) and must have been acquired using the test procedures cited in the *NOx Technical Code 2008*.

These monitoring records shall be kept on board for three months for verification purposes by a Party to the Protocol of 1997. Data shall also be corrected for ambient conditions and fuel specification, and measuring equipment must be checked for correct calibration and operation, in accordance with the approved procedures given in the Onboard Operating Manual.

Where exhaust gas after-treatment devices are fitted which influence the NOx emissions, the measuring point(s) must be located downstream of such devices.

#### **Nitrogen oxides emission standards**

##### **7.4.8 Maximum allowable NOx emission limits for marine diesel engines**

**7.4.8.1** The maximum allowable NOx emission limit values are given by 7.3.2.3, 7.3.2.4, 7.3.2.5-.1.1 and 7.3.2.7-.4 as applicable. The total weighted NOx emissions, as measured and calculated, rounded to one decimal place, in accordance with the procedures in of the *NOx Technical Code 2008*

shall be equal to or less than the applicable calculated value corresponding to the rated speed of the engine.

**7.4.8.2** When the engine operates on test fuel oils in accordance with Chapter 5.3 of the *NOx Technical Code 2008* the total emission of nitrogen oxides (calculated as the total weighted emission of NO<sub>2</sub>) shall be determined using the relevant test cycles and measurement methods as specified in the *NOx Technical Code 2008*.

**7.4.8.3** An engine's exhaust emissions limit value, given from the formulae included in 7.3.2.3, 7.3.2.4, 7.3.2.5-1.1 as applicable, and the actual calculated exhaust emissions value, rounded to one decimal place for the engine, shall be stated on the engine's EIAPP Certificate. If an engine is a Member Engine of an Engine Family or Engine Group, it is the relevant Parent Engine emission value that is compared to the applicable limit value for that Engine Family or Engine Group. The limit value given here shall be the limit value for the Engine Family or Engine Group based on the highest engine speed to be included in that Engine Family or Engine Group, in accordance with paragraph 7.3.2.3, 7.3.2.4, 7.3.2.5-1.1, irrespective of the rated speed of the Parent Engine or the rated speed of the particular engine as given on the engine's EIAPP certificate.

**7.4.8.4** In the case of an engine to be certified in accordance with 7.3.2.5-1.1 the specific emission at each individual mode point shall not exceed the applicable NOx emission limit value by more than 50% except as follows:

- .1 The 10% mode point in the D2 test cycle specified in 7.4.9.5.
- .2 The 10% mode point in the C1 test cycle specified in 7.4.9.6.
- .3 The idle mode point in the C1 test cycle specified in 7.4.9.6.

#### 7.4.9 Test cycles and weighting factors to be applied

**7.4.9.1** For every Individual Engine or Parent Engine of an Engine Family or Engine Group, one or more of the relevant test cycles specified in 7.4.9.2 to 7.4.9.6 shall be applied for verification of compliance with the applicable NOx emission limit contained in 7.3.2.

**7.4.9.2** For constant speed marine diesel engines for ship main propulsion, including diesel electric drive, test cycle E2 shall be applied in accordance with Table 7.4.9.2.

**Table 7.4.9.2**

**Test cycle for Constant-speed main propulsion application (including diesel-electric drive and all controllable-pitch propeller installations)**

Test cycle type E2		
Speed	Power	Weighting factor
100%	100%	0,20
100%	75%	0,50
100%	50%	0,15
100% <sup>a)</sup>	25%	0,15

Note:

a) There are exceptional cases, including large bore engines intended for E2 applications, in which, due to their oscillating masses and construction, engines cannot be run at low load at nominal speed without the risk of damaging essential components. In such cases, the engine manufacturer shall make application to the Administration that the test cycle as given in this Table may be modified for the 25% power mode with regard to the engine speed. The adjusted engine speed at 25% power, however, shall be as close as possible to the rated engine speed, as recommended by the engine manufacturer and approved by the Administration. The applicable weighting factors for the test cycle shall remain unchanged.

**7.4.9.3** For an engine connected to a controllable pitch propeller test cycle E2 shall be applied in accordance with Table 7.4.9.2.

**7.4.9.4** For propeller law operated marine engines, test cycle E3 shall be applied in accordance with Table 7.4.9.4.

**7.4.9.5** For constant speed auxiliary engines, test cycle D2 shall be applied in accordance with Table 7.4.9.5.

**7.4.9.6** For variable speed, variable load auxiliary engines, not included above, test cycle C1 shall be applied in accordance with Table 7.4.9.6.

**Table 7.4.9.4**

**Test cycle for Propeller-law-operated marine engine application**

Test cycle type E3		
Speed	Power	Weighting factor
100%	100%	0,20
91%	75%	0,50
80%	50%	0,15
63%	25%	0,15

**Table 7.4.9.5**

**Test cycle for Constant-speed auxiliary engine application**

Test cycle type D2		
Speed	Power	Weighting factor
100%	100%	0,05
100%	75%	0,25
100%	50%	0,30
100%	25%	0,30
100%	10%	0,10

**Table 7.4.9.6**  
**Test cycle for Variable-speed, variable-load auxiliary engine application**

Test cycle type C1		
Speed	Torque	Weighting factor
Rated	100%	0,15
	75%	0,15
	50%	0,15
	10%	0,10
Intermediate	100%	0,10
	75%	0,10
	50%	0,10
Idle	0%	0,15

**7.4.9.7** The torque figures given in test cycle C1 are percentage values which represent for a given test mode the ratio of the required torque to the maximum possible torque at this given speed.

**7.4.9.8** The intermediate speed for test cycle C1 shall be declared by the manufacturer, taking into account the following requirements:

- .1 For engines which are designed to operate over a speed range on a full load torque curve, the intermediate speed shall be the declared maximum torque speed if it occurs between 60% and 75% of rated speed.
- .2 If the declared maximum torque speed is less than 60% of rated speed, then the intermediate speed shall be 60% of the rated speed.
- .3 If the declared maximum torque speed is greater than 75% of the rated speed, then the intermediate speed shall be 75% of rated speed.
- .4 For engines which are not designed to operate over a speed range on the full load torque curve at steady state conditions, the intermediate speed will typically be between 60% and 70% of the maximum rated speed.

**7.4.9.9** If an engine manufacturer applies for a new test cycle application on an engine already certified under a different test cycle specified in 7.4.9.2 to 7.4.9.6, then it may not be necessary for that engine to undergo the full certification process for the new application. In this case, the engine manufacturer may demonstrate compliance by recalculation, by applying the measurement results from the specific modes of the first certification test to the calculation of the total weighted emissions for the new test cycle application, using the corresponding weighting factors from the new test cycle.

## **7.4.10 Approval for serially manufactured engines: Engine Family and Engine Group concepts**

### **General**

**7.4.10.1** To avoid certification testing of every engine for compliance with the NOx emission limits, one of two approval concepts may be adopted, namely the Engine Family or the Engine Group concept.

**7.4.10.2** The Engine Family concept may be applied to any series produced engines which, through their design are proven to have similar NOx emission characteristics, are used as produced, and, during installation on board, require no adjustments or modifications which could adversely affect the NOx emissions.

**7.4.10.3** The Engine Group concept may be applied to a smaller series of engines produced for similar engine application and which require minor adjustments and modifications during installation or in service on board.

**7.4.10.4** Initially the engine manufacturer may, at its discretion, determine whether engines should be covered by the Engine Family or Engine Group concept. In general, the type of application shall be based on whether the engines will be modified, and to what extent, after testing on a test bed.

### **Documentation**

**7.4.10.5** All documentation for certification must be completed and suitably stamped by the duly authorised Authority as appropriate. This documentation shall also include all terms and conditions, including replacement of spare parts, to ensure that an engine is maintained in compliance with the applicable NOx emission limit.

**7.4.10.6** For an engine within an Engine Family or Engine Group, the required documentation for the Engine Parameter Check method is specified in 7.4.12.2-8.1.

### **Application of the Engine Family concept**

**7.4.10.7** The Engine Family concept provides the possibility of reducing the number of engines which must be submitted for approval testing, while providing safeguards that all engines within the Engine Family comply with the approval requirements. In the Engine Family concept, engines with similar emission characteristics and design are represented by a Parent Engine.

**7.4.10.8** Engines that are series produced and not intended to be modified may be covered by the Engine Family concept.

**7.4.10.9** The necessary details related to the application of the Engine Family concept, containing amongst other:

- .1 Guidance for the selection of an Engine Family;
- .2 Guidance for selecting the Parent Engine of an Engine Family; and
- .3 Certification of an Engine Family;

are stated in Chapter 4.3 of the *NOx Technical Code 2008*.

**Application of the Engine Group concept**

**7.4.10.10** Engine Group engines normally require adjustment or modification to suit the onboard operating conditions but these adjustments or modifications shall not result in NO<sub>x</sub> emissions exceeding the applicable limits in 7.3.2.

**7.4.10.11** The Engine Group concept also provides the possibility for a reduction in approval testing for modifications to engines in production or in service.

**7.4.10.12** The necessary details related to the application of the Engine Family concept, containing amongst other:

- .1 Guidance for the selection of an Engine Group;
- .2 Guidance for allowable adjustment or modification within an Engine Group;
- .3 Guidance for the selection of the Parent Engine of an Engine Group; and
- .4 Certification of an Engine Group;

are stated in Chapter 4.4 of the *NO<sub>x</sub> Technical Code 2008*.

**7.4.10.13** Conformity of production arrangements relative to application of the engine family/group concept is addressed in IACS UI MPC 106.

**7.4.10.14** Additional parameters for definition of the engine group, regarding engines fitted with SCR system to reduce NO<sub>x</sub> emissions, may be used as specified in IACS UI MPC 125 and MPC 126.

**7.4.11 Procedures for NO<sub>x</sub> emission measurements on a test bed**

**7.4.11.1** These procedures shall be applied to every initial approval testing of a marine engine regardless of the location of that testing (the methods described in 7.4.4.2-1 and 7.4.4.2-2).

**7.4.11.2** Chapter 5 of the *NO<sub>x</sub> Technical Code 2008* specifies the measurement and calculation methods for gaseous exhaust emissions from reciprocating internal-combustion engines under steady-state conditions, necessary for determining the average weighted value for the NO<sub>x</sub> exhaust gas emission.

**7.4.11.3** Many of the procedures described in the Chapter 5 of the *NO<sub>x</sub> Technical Code 2008* are detailed accounts of laboratory methods, since determining an emissions value requires performing a complex set of individual measurements, rather than obtaining a single measured value. Thus, the results obtained depend as much on the process of performing the measurements as they depend on the engine and test method.

**7.4.11.4** Chapter 5 of the *NO<sub>x</sub> Technical Code 2008* includes the test and measurement methods, test run and test report as a procedure for a test-bed measurement. That Chapter specifies amongst other:

- .1 Test conditions;
- .2 Test fuel oils;
- .3 Measurement equipment and data to be measured;
- .4 Determination of exhaust gas flow;

- .5 Permissible deviations of instruments for engine-related parameters and other essential parameters;
- .6 Analysers for determination of the gaseous components;
- .7 Calibration of the analytical instruments;
- .8 Test run;
- .9 Test report;
- .10 Data evaluation for gaseous emissions; and
- .11 Calculation of the gaseous emissions.

**7.4.11.5** The weighting factors and the number of modes used in the calculation in accordance with the calculation 7.4.11.4-.11 shall be according to the provisions of 7.4.9.

**7.4.11.6** The resulting average weighted NO<sub>x</sub> emission value for the engine as determined the calculation 7.4.11.4-.11 shall then be compared to the applicable emission limit given in 7.3.2 to determine if the engine is in compliance.

**7.4.12 Procedures for demonstrating compliance with NO<sub>x</sub> emission limits on board**

**7.4.12.1** After installation of a pre-certificated engine on board a ship, every marine diesel engine shall have on-board verification surveys conducted as specified in 7.4.4.1-2 to 7.4.4.1-4), to verify that the engine continues to comply with the NO<sub>x</sub> emission limit contained in 7.3.2. Such verification of compliance shall be determined by using one of the following methods:

- .1 Engine Parameter Check method in accordance with 7.4.12.2 to verify that an engine's component, settings and operating values have not deviated from the specifications in the engine's Technical File;
- .2 Simplified Measurement method in accordance with 7.4.12.3; or
- .3 Direct Measurement and Monitoring method in accordance with 7.4.12.4.

**7.4.12.2 Engine Parameter Check method**

- .1 Engines that meet the following conditions shall be eligible for an Engine Parameter Check method:
  - .1 engines that have received a pre-certificate (EIAPP Certificate) on the test bed and those that received a certificate (EIAPP Certificate) following an initial certification survey in accordance with 7.4.5.4; and
  - .2 engines that have undergone modifications or adjustments to the designated engine components and adjustable features since they were last surveyed.
- .2 When a marine diesel engine is designed to run within the applicable NO<sub>x</sub> emission limit, it is most likely that within the marine life of the engine, the NO<sub>x</sub> emission limit may be adhered to. The applicable NO<sub>x</sub> emission limit may, however, be contravened by adjustments or modifi-

cation to the engine. Therefore, an Engine Parameter Check method shall be used to verify whether the engine is still within the applicable NOx emission limit.

- .3 Engine component checks, including checks of settings and an engine's operating values, are intended to provide an easy means of deducing the emissions performance of the engine for the purpose of verification that an engine with no, or minor adjustments or modifications complies with the applicable NOx emission limit. Where the measurement of some operating values is required, the calibration of the equipment used for those measurements shall be in accordance with the requirements of appendix 4 of the *NOx Technical Code 2008*.
- .4 The purpose of such checks is to provide a ready means of determining that an engine is correctly adjusted in accordance with the manufacturer's specification and remains in a condition of adjustment consistent with the initial certification by the Administration as being in compliance with 7.3.2 as applicable.
- .5 If an electronic engine management system is employed, this shall be evaluated against the original settings to ensure that appropriate parameters are operating within *as-built* limits.
- .6 For the purpose of assessing compliance with 7.3.2, it is not always necessary to measure the NOx emissions to know that an engine, not equipped with an after-treatment device, is likely to comply with the applicable NOx emission limit. It may be sufficient to know that the present state of the engine corresponds to the specified components, calibration or parameter adjustment state at the time of initial certification. If the results of an Engine Parameter Check method indicate the likelihood that the engine complies with the applicable NOx emission limit, the engine may be re-certified without direct NOx measurement.
- .7 For an engine equipped with a NOx reducing device, it will be necessary to check the operation of the device as part of the Engine Parameter Check method.
- .8 The remaining details specifying:
  - .1 documentation; and
  - .2 procedures;

for the Engine Parameter Check method have been stated in the Chapter 6.2 of the *NOx Technical Code 2008*.

#### 7.4.12.3 Simplified Measurement method

- .1 The simplified test and measurement procedure, as specified in the Chapter 6.3 of the *NOx Technical Code 2008*, shall be applied only for onboard confirmation tests and renewal, annual and intermediate surveys when required. Every first engine testing on a test bed shall be carried out in accordance with the procedure specified in 7.4.11. Corrections for ambient air temperature and humidity are essential as ships are sailing in cold/hot and dry/humid climates, which may cause a difference in NOx emissions.
- .2 To gain meaningful results for onboard confirmation tests and onboard renewal, annual and intermediate surveys, as an absolute minimum, the gaseous emission concentrations of NOx and CO<sub>2</sub> shall be measured in accordance with the appropriate test cycle. The weighting factors and the number of modes used in the calculation shall be in accordance with 7.4.9.
- .3 The engine torque and engine speed shall be measured but, to simplify the procedure, the permissible deviations of instruments for measurement of engine-related parameters for onboard verification purposes is different than from those permissible deviations allowed under the test-bed testing method. If it is difficult to measure the torque directly, the brake power may be estimated by any other means recommended by the applicant for engine certification and approved by the Administration.
- .4 The remaining necessary details specifying amongst other:
  - .1 engine parameters to be measured and recorded;
  - .2 brake power;
  - .3 test fuel oils;
  - .4 sampling for gaseous emissions;
  - .5 measurement equipment and data to be measured;
  - .6 permissible deviation of instruments for engine related parameters and other essential parameters;
  - .7 determination of the gaseous components;
  - .8 test cycles;
  - .9 calculation of gaseous emissions; and
  - .10 allowances

for the Simplified Measurement method have been stated in the Chapter 6.3 of the *NOx Technical Code 2008*.

#### 7.4.12.4 Direct Measurement and Monitoring method

- .1 The Direct Measurement and Monitoring procedure may be applied for onboard



verification at renewal, annual and intermediate surveys.

- .2 Due attention is to be given to the safety implications related to the handling and proximity of exhaust gases, the measurement equipment and the storage and use of cylindered pure and calibration gases. Sampling positions and access staging shall be such that this monitoring may be performed safely and will not interfere with the engine.
- .3 Onboard NO<sub>x</sub> monitoring includes, as an absolute minimum, the measurement of gaseous emission concentrations of NO<sub>x</sub> (as NO+NO<sub>2</sub>).
- .4 The remaining necessary details specifying amongst other:
  - .1 emission species measurement;
  - .2 engine performance measurements;
  - .3 ambient condition measurements;
  - .4 engine performance and ambient condition monitoring equipment;
  - .5 test cycles;
  - .6 test condition parameter;
  - .7 analyser in-service performance;
  - .8 data for emission calculation;
  - .9 exhaust gas flow rate;
  - .10 fuel oil composition;
  - .11 dry/wet correction;
  - .12 NO<sub>x</sub> correction for humidity and temperature;
  - .13 calculation of emission flow rates and specific emissions;
  - .14 limit value and allowances; and
  - .15 data for demonstrating compliance;

for the Direct Measurement and Monitoring method have been stated in the Chapter 6.3 of the *NO<sub>x</sub> Technical Code 2008*.

- .5 Form of approval
 

The Direct Measurement and Monitoring method shall be documented in an Onboard Monitoring Manual. The Onboard Monitoring Manual shall be submitted to the Administration for approval. The approval reference of that Onboard Monitoring Manual shall be entered under section 3 of the Supplement to the EIAPP Certificate. The Administration may issue a new EIAPP Certificate, with the details in section 3 of the Supplement duly amended, if the method is approved after the issue of the first EIAPP Certificate, i.e. following the pre-certification survey
- .6 Survey of equipment and method
 

The survey of the Direct Measurement and Monitoring method shall take into account, but is not limited to:

- .1 the data obtained and developed from the required measurements; and
- .2 the means by which that data has been obtained, taking into account the information given in the Onboard Monitoring Manual.

#### 7.4.13 Certification of an Existing Engine

**7.4.13.1** Where an Existing Engine is to comply with 7.3.2.7, then the entity responsible for obtaining emissions certification shall apply to the approving Administration for certification.

**7.4.13.2** Where an application for Approved Method approval includes gaseous emission measurements and calculations, those are to be in accordance with 7.4.11.

**7.4.13.3** Emission and performance data obtained from one engine may be shown to apply to a range of engines.

**7.4.13.4** The Approved Method for achieving compliance with 7.3.2.7 shall include a copy of the Approved Method File which is required to accompany the engine throughout its life on board ship.

**7.4.13.5** A description of the engine's onboard verification procedure shall be included in the Approved Method File.

**7.4.13.6** After installation of the Approved Method, a survey shall be conducted in accordance with the Approved Method File. If this survey confirms compliance, the Administration shall amend the ship's IAPP Certificate accordingly.

**7.4.13.7** Guidelines on the approved method process are set out in IMO Res. MEPC.243(66).

#### 7.4.14 Additional reference information

**7.4.14.1** Flowcharts for survey and certification of marine diesel engines (referred to 7.4.5.9 and 7.4.6.11) are available in the Appendix 2 of the *NO<sub>x</sub> Technical Code 2008*.

**7.4.14.2** Specifications for analysers to be used in the determination of gaseous components of marine diesel engine emissions (referred to 7.4.11) are stated in the Appendix 3 of the *NO<sub>x</sub> Technical Code 2008*.

**7.4.14.3** Calibration of the analytical and measurement instruments (referred to 7.4.10, 7.4.11 and 7.4.12) are stated in the Appendix 4 of the *NO<sub>x</sub> Technical Code 2008*.

**7.4.14.4** Parent Engine test report and test data (referred to 7.4.7.1-5 and 7.4.11.4-9) are stated in the Appendix 5 of the *NO<sub>x</sub> Technical Code 2008*.

**7.4.14.5** Calculation of exhaust gas mass flow, i.e. carbon-balance method (referred to 7.4.11) are stated in the Appendix 6 of the *NO<sub>x</sub> Technical Code 2008*.

**7.4.14.6** Implementation of the Direct Measurement and Monitoring method (referred to 7.4.12.4) are stated in the Appendix 8 of the *NO<sub>x</sub> Technical Code 2008*.

## 8 CONTROL OF HARMFUL ANTI-FOULING SYSTEMS ON SHIPS

### 8.1 GENERAL REQUIREMENTS

#### 8.1.1 General

Requirements of this Chapter are based on the AFS Convention, as well as the Regulation EC No. 782/2003.

#### 8.1.2 Application

Requirements of this Chapter applies on the ships as they defined in 8.1.3.2.

#### 8.1.3 Definitions

For the purpose of this Chapter of the Rules the following definition are applied.

**8.1.3.1 Anti-fouling system** – means a coating, paint, surface, or device that is used on a ship to control or prevent attachment of unwanted organisms.

**8.1.3.2 Ship** – means a vessel of any type whatsoever operating in the marine environment and includes hydrofoil boats, air-cushion vehicles, submersibles, floating craft, fixed or floating platforms, floating storage units (FSU-s) and floating production storage and off-loading units (FPSOs).

**8.1.3.3 AFS Convention** – means the International Convention on the Control of Harmful Anti-fouling Systems on Ships, 2001.

**8.1.3.4 Regulation EC No. 782/2003** – means the Regulation of the European Parliament and of the Council of 14th April 2003 on the prohibition of organotin compounds on ships.

**8.1.3.5 Length** – means the length as defined in the International Convention on Load Lines, 1966, as modified by the Protocol of 1988 relating thereto.

### 8.2 HARMFUL ANTI-FOULING SYSTEMS ON SHIPS AND CONTROL MEASURES

#### 8.2.1 Harmful anti-fouling systems

**8.2.1.1** Organotin compounds which act as biocides in anti-fouling systems are considered as harmful.

#### 8.2.2 Control measures

**8.2.2.1** Anti-fouling systems as stated in 8.2.1 shall not be applied or reapplied on ships.

**8.2.2.2** Ship:

- either shall not bear the anti-fouling system as stated in 8.2.1
- or shall bear a coating that forms a barrier to such system leaching from the underlying harmful anti-fouling system.

**8.2.3** **Intentionally blank**

**8.2.3.1** **Intentionally blank.**

**8.2.3.2** **Intentionally blank.**

**8.2.3.3** **Intentionally blank.**

*Note:*

*In accordance with provisions of the Regulation EC 782/2003 as from 1st January 2008 all ships irrespective of their flag that enter an EU parts shall be in compliance with 8.2.2.2.*

### 8.3 SURVEY AND CERTIFICATION REQUIREMENTS FOR ANTI-FOULING SYSTEMS ON SHIPS

#### 8.3.1 Surveys

Ships of 400 gross tonnage and above, excluding fixed or floating platforms, floating storage units (FSU) and floating production storage and off-loading units (FPSO), shall be subject to the surveys as stated in 8.3.1.1 to 8.3.1.3.

**8.3.1.1** An initial survey shall be performed before the ship is put into service or before the International Anti-fouling System Certificate is issued for the first time.

**8.3.1.2** A survey shall be performed when the anti-fouling system are changed or replaced which shall be endorsed in certificate as stated in 8.3.2.1.

**8.3.1.3** The survey shall be such as to ensure that ship's anti-fouling system complies with 8.2.2 of this Chapter.

#### 8.3.2 Certificates

**8.3.2.1** After completion of a survey referred to in point 8.3.1 the International Anti-fouling System Certificate shall be issued.

The certificate shall cease to be valid if the anti-fouling system is changed and replaced and the certificate is not endorsed in accordance with 8.3.1.2.

**8.3.2.2** A ship of 24 m or more in length, but less than 400 gross tonnage excluding fixed or floating platforms, floating storage units (FSU) and floating production storage and off-loading units (FPSO) shall carry a Declaration on Anti-fouling System, signed by owner or his authorised representative.

Such Declaration shall be accompanied by appropriate documentation enable to confirm that anti-fouling system applied is not that stated in 8.2.

## 9 ENERGY EFFICIENCY FOR SHIPS

### 9.1 GENERAL

#### 9.1.1 Application

The provisions of this Chapter shall apply to all ships (as defined in item 1.1.2.4) of 400 gross tonnage and above engaged on international voyages, except where expressly provided otherwise in item 9.2.1.

The provisions of this Chapter in 9.2.2 and 9.2.3 shall apply to new ships engaged on voyages within area of navigation 5 to 8, of 400 gross tonnage and above, listed in table 9.2.3.1.

#### 9.1.2 Definitions

**9.1.2.1 Existing ship** – means a ship which is not a new ship.

**9.1.2.2 New ship** – means a ship:

- .1 for which the building contract is placed on or after 1st January 2013; or
- .2 in the absence of a building contract, the keel of which is laid or which is at a similar stage of construction on or after 1st July 2013; or
- .3 the delivery of which is on or after 1st July 2015.

**9.1.2.3 Major conversion** – means a conversion of a ship:

- .1 which substantially alters the dimensions, carrying capacity or engine power of the ship; or
- .2 which changes the type of the ship; or
- .3 the intent of which in the opinion of the Register is substantially to prolong the life of the ship; or
- .4 which otherwise so alters the ship that, if it were a new ship, it would become subject to relevant provisions of the present Rules not applicable to it as an existing ship; or
- .5 which substantially alters the energy efficiency of the ship and includes any modifications that could cause the ship to exceed the applicable required EEDI as set out in item 9.2.3.

**9.1.2.4 Energy efficiency design index (EEDI)** – measure of ships energy efficiency [ $\text{g CO}_2/\text{t} \cdot \text{nm}$ ].

**9.1.2.5 Attained EEDI** – means the EEDI value achieved by an individual ship in accordance with item 9.2.2.

**9.1.2.6 Required EEDI** – means the maximum value of attained EEDI that is allowed by item 9.2.3 for the specific ship type and size.

**9.1.2.7 Conventional propulsion** – means a method of propulsion where a main reciprocating internal combustion

engine is the prime mover and coupled to a propulsion shaft either directly or through a gear box.

**9.1.2.8 Non-conventional propulsion** – means a method of propulsion other than conventional propulsion, including diesel-electric propulsion, turbine propulsion and hybrid propulsion systems.

**9.1.2.9 Cargo ship having ice-breaking capability** – means a cargo ship which is designed to break level ice independently with a speed of at least 2 knots when the level ice thickness is 1,0 m or more having ice bending strength of at least 500 kPa.

**9.1.2.10 Ship delivered on or after 1st September 2019** – means a ship:

- .1 for which the building contract is placed on or after 1st September 2015; or
- .2 in the absence of a building contract, the keel of which is laid or which is at a similar stage of construction on or after 1st March 2016; or
- .3 the delivery of which is on or after 1st September 2019.

**9.1.2.11 Calendar year** – means the period from 1st January until 31st December inclusive.

**9.1.2.12 Company** – means the owner of the ship or any other organization or person such as the manager, or the bareboat charterer, who has assumed the responsibility for operation of the ship from the owner and who on assuming such responsibility has agreed to take over all the duties and responsibilities imposed by the ISM Code, as amended.

**9.1.2.13 Distance travelled** – means distance travelled over ground.

#### 9.1.3 Scope of supervision

**9.1.3.1** Survey and certification process of the Energy efficiency design index (EEDI) is described in IMO Res. MEPC.254(67) and IMO Res. MEPC.261(68), and in IACS PR No.38.

**9.1.3.2** EEDI Technical file shall be submitted to Register for verification.

The EEDI Technical file shall include the following:

- .1 deadweight (DWT) or gross tonnage (GT), the maximum continuous rating (MCR) of the main and auxiliary engines, the ship speed ( $v_{ref}$ ), type of fuel, the specific fuel consumption (SFC) of the main and auxiliary engines, and the electric power table, as necessary;
- .2 power curves (kW – knot) estimated at design stage in fully loaded condition (maximum summer load draught or draught corresponding to 70% of the ship's deadweight for container ships) and under the sea trial condition;
- .3 principal particulars, information about ship type, classification notations and the overview of propulsion system and electricity supply system onboard;

- .4 estimation process and methodology of the power curves at design stage;
- .5 description of energy saving equipment;
- .6 calculated value of the attained EEDI including the calculation summary;
- .7 calculated values of the attained EEDI<sub>weather</sub> and f<sub>w</sub> value, if those values are calculated.

**9.1.3.3** The *Register* may request the submitter for additional information, as necessary, to examine the calculation process of the attained EEDI.

Additional information may include the following:

- .1 description of a tank test facility;
- .2 lines of a model ship and an actual ship;
- .3 lightweight of the ship and displacement table for the verification of the deadweight;
- .4 detailed report on the method and results of the tank test;
- .5 detailed calculation process of the ship speed;
- .6 reasons for exempting a tank test, if applicable.

**9.1.3.4** *Register* shall issue the report on the preliminary verification of EEDI after verification of the attained EEDI at the design stage.

**9.1.3.5** Prior to the sea trial, test procedure for the speed trial is to be submitted to the *Register*. The final displacement table and the measured lightweight, or a copy of the survey report of deadweight, and a copy of NOx Technical file are to be available to the *Register*.

**9.1.3.6** The *Register* shall attend the sea trial and confirm:

- .1 propulsion and power supply system and other relevant items described in the EEDI Technical file;
- .2 draught and trim;
- .3 sea conditions;
- .4 ship speed;
- .5 shaft power and RPM of the main engine.

**9.1.3.7** The EEDI Technical file shall be revised, as necessary, by taking into account results of sea trial. Such revision shall include the adjusted power curve based on the results of speed trial, the finally determined deadweight/gross tonnage, SFC described in the approved NOx Technical file, and the recalculated attained EEDI based on these modifications.

**9.1.3.8** The revised EEDI Technical file shall be submitted to *Register* for the final verification and confirmation of the attained EEDI.

**9.1.3.9** In case where a major conversion is made to a ship, the revised EEDI Technical file shall be submitted to *Register* for verification.

**9.1.3.10** The revised EEDI Technical file in case of a major conversion shall include the following:

- .1 details of the conversion;
- .2 EEDI parameters changed after the conversion with relevant technical justifications for each parameter;
- .3 reasons for other changes made in the EEDI Technical file, if any;
- .4 calculated value of the attained EEDI with the calculation summary.

**9.1.3.11** For verification of the attained EEDI after a conversion, speed trials of the ship are required, as necessary.

## 9.2 REQUIREMENTS ON ENERGY EFFICIENCY FOR SHIPS

### 9.2.1 Application

**9.2.1.1** Item 9.2.2 and 9.2.3 shall apply to each new ship, each new ship which has undergone a major conversion and each new or existing ship which has undergone a major conversion, that is so extensive that the ship is regarded by the *Register* as a newly constructed ship.

**9.2.1.2** Item 9.2.2 and 9.2.3 shall not apply to ships which have non-conventional propulsion, except cruise passenger ships having non-conventional propulsion and LNG carriers having conventional or non-conventional propulsion, delivered on or after 1<sup>st</sup> September 2019. Items 9.2.2 and 9.2.3 shall not apply to cargo ships having ice-breaking capability.

**9.2.1.3** Item 9.2 shall not apply to ships not propelled by mechanical means and platforms including FPSO, FSU and drilling rigs, regardless of their propulsion.

### 9.2.2 Attained energy efficiency design index (Attained EEDI)

**9.2.2.1** The attained EEDI shall be calculated taking into account guidelines in IMO Res. MEPC.245(66), IMO Res. MEPC.263(68) and IMO Res. MEPC.281(70).

**9.2.2.2** The attained EEDI shall be verified, based on the EEDI technical file, by the Register, taking into account guidelines in IMO Res. MEPC.254(67) and IMO Res. MEPC.261(68).

### 9.2.3 Required EEDI

**9.2.3.1** The attained EEDI shall be as follows:

$$\text{Attained EEDI} \leq \text{Required EEDI} = (1 - X/100) \times \text{Reference line value}$$

where *X* is the reduction factor specified in Table 9.2.3.1 for the required EEDI compared to the EEDI reference line.

**Table 9.2.3.1**  
Reduction factor

SHIP TYPE	SIZE (DWT)	PHASE 0 1.1.2013.- 31.12.2014.	PHASE 1 1.1.2015.- 31.12.2019.	PHASE 2 1.1.2020.- 31.12.2024	PHASE 3 1.1.2025. and onwards
Bulk carrier	20000 and above	0	10	20	30
	10000-20000	N/a	0-10*	0-20*	0-30*
Gas carrier	10000 and above	0	10	20	30
	2000-10000	N/a	0-10*	0-20*	0-30*
Tanker	20000 and above	0	10	20	30
	4000-20000	N/a	0-10*	0-20*	0-30*
Container ship	15000 and above	0	10	20	30
	10000-15000	N/a	0-10*	0-20*	0-30*
General cargo ship	15000 and above	0	10	15	30
	3000-15000	N/a	0-10*	0-15*	0-30*
Refrigerated cargo carrier	5000 and above	0	10	15	30
	3000-5000	N/a	0-10*	0-15*	0-30*
Combination carrier	20000 and above	0	10	20	30
	4000-20000	N/a	0-10*	0-20*	0-30*
LNG carrier***	10000 and above	N/a	10**	20	30
Ro-ro cargo ship (vehicle carrier)***	10000 and above	N/a	5**	15	30
Ro-ro cargo ship***	2000 and above	N/a	5**	20	30
	1000-2000	N/a	0-5***	0-20*	0-30*
Ro-ro passenger ship***	1000 and above	N/a	5**	20	30
	250-1000	N/a	0-5***	0-20*	0-30*
Cruise passenger ship*** having non-conventional propulsion	85000 GT and above	N/a	5**	20	30
	25000-85000 GT	N/a	0-5***	0-20*	0-30*

\* Reduction factor to be linearly interpolated between the two values dependent upon vessel size.

N/a – means that no required EEDI applies.

\*\* Phase 1 commences on 1<sup>st</sup> September 2015.

\*\*\* Reduction factor applies to ships delivered on or after 1<sup>st</sup> September 2019.

**9.2.3.2** The attained EEDI, for each new or existing ship which has undergone a major conversion, that is so extensive that the ship is regarded by the Register as a newly constructed ship, shall be calculated with the reduction factor applicable corresponding to the ship type and size of the converted ship at the date of the contract of the conversion, or in the absence of a contract, the commencement date of the conversion.

**9.2.3.3** The reference line values shall be calculated as follows:

$$\text{Reference line value} = a \times b^{-c}$$

where  $a$ ,  $b$  and  $c$  are the parameters given in Table 9.2.3.3

**Table 9.2.3.3**  
Parameters for determination of reference line values

Ship type	<i>a</i>	<i>b</i>	<i>c</i>
Bulk carrier	961,79	DWT of the ship	0,477
Gas carrier	1120,00	DWT of the ship	0,456
Tanker	1218,80	DWT of the ship	0,488
Container ship	174,22	DWT of the ship	0,201
General cargo ship	107,48	DWT of the ship	0,216
Refrigerated cargo carrier	227,01	DWT of the ship	0,244
Combination carrier	1219,00	DWT of the ship	0,488
Ro-ro cargo ship (vehicle carrier)	(DWT/GT) <sup>-0,7</sup> · 780,36 where DWT/GT < 0,3 1812,63 where DWT/GT ≥ 0,3	DWT of the ship	0,471
Ro-ro cargo ship	1405,15	DWT of the ship	0,498
	1686,17 *	DWT of the ship where DWT ≤ 17000 * 17000 where DWT > 17000 *	
Ro-ro passenger ship	752,16	DWT of the ship	0,381
	902,59 *	DWT of the ship where DWT ≤ 10000 * 10000 where DWT > 10000 *	
LNG carrier	2253,7	DWT of the ship	0,474
Cruise passenger ship having non-conventional propulsion	170,84	GT of the ship	0,214

\*to be used from phase 2 and thereafter

**9.2.3.4** For each ship to which item 9.2.2 and 9.2.3 applies, the installed propulsion power shall not be less than the propulsion power needed to maintain the manoeuvrability of the ship under adverse conditions as defined in Guidelines in IMO Res. MEPC.232(65), IMO Res. MEPC.255(67) and IMO Res. MEPC.262(68).

**9.2.4 Ship energy efficiency management plan (SEEMP)**

**9.2.4.1** Each ship of 400 gross tonnage and above shall keep onboard a ship specific Ship energy efficiency management plan (SEEMP). It may form part of the ship's Safety management system (SMS).

**9.2.4.2** The SEEMP shall be developed taking into account guidelines in IMO Res. MEPC.282(70).

**9.2.4.3** On or before 31<sup>st</sup> December 2018, in the case of a ship of 5000 GT and above, the SEEMP shall include a description of the methodology that will be used to collect the data required by item 9.3.1 and the processes that will be used to report the data to the ship's administration.

**9.2.4.4** The Administration shall ensure that for each ship to which item 9.3 applies, the SEEMP complies with 9.2.4.3. This shall be done prior to collecting data under 9.3 in order to ensure the methodology and processes are in place prior to beginning of the ship's first reporting period. Confirmation of compliance shall be provided to and retained onboard the ship.

**9.3 COLLECTION AND REPORTING OF SHIP FUEL OIL CONSUMPTION DATA**

**9.3.1** From calendar year 2019, each ship of 5000 GT and above shall collect the following data:

- identity of the ship: IMO number,
- period of calendar year for which the data is submitted: start date and end date;
- technical characteristics of the ship: ship type, gross tonnage, net tonnage, deadweight tonnage, power output (rated power) of main and auxiliary reciprocating internal combustion engines over 130 kW, EEDI (if applicable), ice class (if applicable),
- fuel oil consumption, by fuel oil type in metric tonnes and methods used for collecting fuel oil consumption data,
- distance travelled,
- hours underway,

for that and each subsequent calendar year or portion thereof, as appropriate, according to the methodology included in the SEEMP.

**9.3.2** At the end of each calendar year, the ship shall aggregate the data collected in that calendar year or portion thereof, as appropriate.

**9.3.3** Within three months after the end of each calendar year, the ship shall report to its Administration or any organization duly authorized by it, the aggregated value for each datum specified in 9.3.1, via electronic communication and using a standardized format shown in appendix 3 of IMO Res. MEPC.282(70).

**9.3.4** In the event of the transfer of a ship from one Administration to another, in the event of a change from one company to another, or in the event of a change from one Administration to another and from one company to another concurrently, the ship shall on the day of completion of the transfer/change or as close as practical thereto report to the losing Administration/to its Administration or any organization duly authorized by it, the aggregated data for the portion of the calendar year corresponding to that Administration/to the company, as specified in 9.3.1 and upon request of the Administration, the disaggregated data.

**9.3.5** The data shall be verified according to procedures established by the Administration, taking into account guidelines in IMO Res. MEPC.292(71).

**9.3.6** The disaggregated data that underlies the reported data noted in 9.3.1 for the previous calendar year shall be readily accessible for a period of not less than 12 months from the end of that calendar year and be made available to the Administration upon request.

**9.3.7** Upon receipt of reported data pursuant to 9.3.3 and 9.3.4, the Administration or any organization duly authorized by it shall determine whether the data has been reported in accordance with 9.3 and, if so, issue the Statement of Compliance related to fuel oil consumption to the ship. This statement shall be issued no later than five months from the beginning of the calendar year, or in the event of 9.3.4 this statement shall be issued promptly at the time of receipt of data.

**9.3.8** The Statement of Compliance shall be drawn up in a form corresponding to the model given in appendix X to Annex VI.

**9.3.9** The Statement of Compliance shall be valid for the calendar year in which it is issued and for the first five months of the following calendar year, or in the event of 9.3.4 this statement shall be valid for the calendar year in which it is issued, for the following calendar year and for the first five months of the subsequent calendar year. All Statements of Compliance shall be kept on board for at least the period of their validity.

**9.3.10** The Administration shall ensure that the reported data noted in 9.3.1 by its registered ships of 5000 GT and above are transferred to the IMO Ship Fuel Oil Consumption Database via electronic communication and using a standardized format developed by IMO not later than one month after issuing the Statements of Compliance of these ships.

**9.3.11** IMO shall maintain an anonymized database such that identification of a specific ship will not be possible. Parties shall have access to the database strictly for their analysis and consideration. Guidelines for database management are given in IMO Res. MEPC.293(71).

## 10 CONTROL AND MANAGEMENT OF SHIPS' BALLAST WATER AND SEDIMENTS

### 10.1 GENERAL REQUIREMENTS

#### 10.1.1 General

Requirements of this Chapter are based on the *International convention for the control and management of ships' ballast water and sediments*, 2004. International convention for the control and management of ships' ballast water and sediments will enter into force on 8th September 2017.

#### 10.1.2 Application

**10.1.2.1** Requirements of this Chapter apply to ships engaged on international voyages designed or constructed to carry ballast water.

**10.1.2.2** About application of this Chapter to ships engaged on voyages within area of navigation 3 and 4 decides Ministry specifically in every case, taking into account Guidelines for risk assessment under regulation A-4 of BWM convention (G7), IMO Res. [MEPC.289\(71\)](#).

**10.1.2.3** **Intentionally blank.**

#### 10.1.3 Definitions

For the purpose of this Chapter, the following definitions apply:

**10.1.3.1 Ballast water** – means water with its suspended matter taken on board a ship to control trim, list, draught, stability or stresses of the ship.

**10.1.3.2 Sediments** – means matter settled out of ballast water within a ship.

**10.1.3.3 Ballast water management** – means mechanical, physical, chemical, and biological processes, either singularly or in combination, to remove, render harmless, or avoid the uptake or discharge of harmful aquatic organisms and pathogens within ballast water and sediments.

**10.1.3.4 Harmful aquatic organisms and pathogens** – means aquatic organisms or pathogens which, if introduced into the sea including estuaries, or into fresh water courses, may create hazards to the environment, human health, property or resources, impair biological diversity or interfere with other legitimate uses of such areas.

**10.1.3.5 Active substance** – means a substance or organism, including a virus or a fungus, that has a general or specific action on or against harmful aquatic organisms and pathogens.

**10.1.3.6 Convention** – means the International Convention for the Control and Management of Ships' Ballast Water and Sediments.

**10.1.3.7 Certificate** – means the International Ballast Water Management Certificate.

**10.1.3.8 Anniversary date** – means the day and the month of each year corresponding to the date of expiry of the certificate.

**10.1.3.9 Ballast water capacity** – means the total volumetric capacity of any tanks, spaces or compartments on a ship used for carrying, loading or discharging ballast water, including any multi-use tank, space or compartment designed to allow carriage of ballast water.

**10.1.3.10 Constructed** – in respect of a ship means a stage of construction where:

- .1 the keel is laid; or
- .2 construction identifiable with the specific ship begins; or
- .3 assembly of the ship has commenced comprising at least 50 tonnes or 1 percent of the estimated mass of all structural material, whichever is less; or
- .4 the ship undergoes a major conversion.

**10.1.3.11 Major conversion** – means a conversion of a ship:

- .1 which changes its ballast water carrying capacity by 15 percent or greater, or
- .2 which changes the ship type, or
- .3 which, in the opinion of the *Register*, is projected to prolong its life by ten years or more, or
- .4 which results in modifications to its ballast water system other than component replacement-in-kind. Conversion of a ship to meet the provisions of 10.2.6 shall not be deemed to constitute a major conversion for the purpose of this Chapter.

**10.1.3.12 From the nearest land** – means from the baseline from which the territorial sea of the territory in question is established in accordance with international law.

**10.1.3.13 Ballast water management system (BWMS)** – means any system which processes ballast water such that it meets or exceeds the ballast water performance standard in 10.2.7 The BWMS includes ballast water treatment equipment, all associated control equipment, monitoring equipment and sampling facilities.

**10.1.3.14 Ballast water treatment equipment** – means equipment which mechanically, physically, chemically, or biologically processes, either singularly or in combination, to remove, render harmless, or avoid the uptake or discharge of harmful aquatic organisms and pathogens within ballast water and sediments.

Ballast water treatment equipment may operate at the uptake or discharge of ballast water, during the voyage, or at a combination of these events.

**10.1.3.15 Control equipment** – means installed equipment required to operate and control the ballast water treatment equipment.

**10.1.3.16 Monitoring equipment** – means equipment installed for the assessment of the effective operation of the ballast water treatment equipment.



**10.1.3.17 Sampling facilities** – means equipment provided for sampling treated or untreated ballast water as needed in the **BWMS Code** and in the Guidelines for ballast water sampling (G2), IMO Res. MEPC.173(58).

**10.1.3.18 Treatment rated capacity (TRC)** – means the maximum continuous capacity expressed in cubic metres per hour for which the BWMS is type approved. It states the amount of ballast water that can be treated per unit time by the BWMS to meet the standard in 10.2.7.

## 10.1.4 Scope of supervision

### 10.1.4.1 Intentionally blank.

**10.1.4.2** Supervision during construction shall cover:

- .1 ballast water treatment equipment;
- .2 control and monitoring equipment;
- .3 systems for uptake, discharge and sampling of ballast water;
- .4 systems for transfer of ballast water to reception facilities, if applicable.

**10.1.4.3** Technical documentation for ballast water management systems which shall be submitted to *Register* for approval shall include at least the following:

.1 BWMS technical specification, including at least:

- .1 description of the BWMS, treatment processes it employs and details of any required permits;
- .2 adequate information including descriptions and diagrammatic drawings of the pumping and piping arrangements, electrical/electronic wiring, monitoring system, waste streams and sampling points;
- .3 details of major components and materials used (including certificates where appropriate);
- .4 an equipment list showing all components subject to testing including specifications, materials and serial numbers;
- .5 an installation specification in accordance with manufacturers installation criteria requirements for the location and mounting of components, arrangements for maintaining the integrity of the boundary between safe and hazardous spaces and the arrangement of the sample piping;
- .6 information regarding the characteristics and arrangements in which the system is to be installed, including scope of the ships (sizes, types and operation) for which the system is intended; and
- .7 description of BWMS side streams (filtered material, centrifugal concentrate, waste or residual chemicals) including a description of the actions planned to properly manage and dispose of such wastes;

.2 the operation, maintenance and safety manual, including at least:

- .1 instructions for the correct operation of the BWMS, including procedures for the

discharge of untreated water in the event of malfunction of the ballast water treatment equipment;

.2 instructions for the correct arrangement of the BWMS;

.3 maintenance and safety instructions and the need to keep records;

.4 troubleshooting procedures;

.5 emergency procedures necessary for securing the ship;

.6 any supplementary information considered necessary for the safe and efficient operation of the BWMS, documentation provided for approval under the procedure (G9); and

.7 calibration procedures;

.3 information on any hazard identification conducted to identify potential hazards and define appropriate control measures, if the BWMS or the storage tanks for processing chemicals could emit dangerous gases or liquids;

.4 information regarding environmental and public health impacts including:

.1 identification of potential hazards to the environment based on environmental studies performed to the extent necessary to assure that no harmful effects are to be expected;

.2 in the case of BWMS that make use of active substances or preparations containing one or more active substances, the dosage of any active substances used and the maximum allowable discharge concentrations;

.3 in the case of BWMS that do not make use of active substances or preparations, but which could reasonably be expected to result in changes to the chemical composition of the treated water such that adverse impacts to receiving waters might occur upon discharge, the documentation shall include results of toxicity tests of treated water as described in procedure (G9); and

.4 sufficient information to enable the test organization to identify any potential health or environmental safety problems, unusual operating requirements (labour or materials), and any issues related to the disposal of treatment by-products or waste streams;

.5 information regarding system design limitations including:

.1 identification of all known parameters to which the design of the BWMS is sensitive;

.2 for each parameter the manufacturer shall claim a low and/or a high value for which the BWMS is capable of achieving the performance standard in 10.2.7; and

.3 the proposed method for validating each claimed SDL shall be set out, together with information on the source, suitability and reliability of the method;

- .6 software change handling and revision control document including all software changes introduced to the system after the pre-test evaluation.
- .7 functional description, including a textual description with necessary supporting drawings, diagrams and figures to cover:
  - .1 system configuration and arrangement;
  - .2 scope of supply;
  - .3 system functionality covering control, monitoring, alarm and safety functions;
  - .4 self-diagnostics and alarming functionalities; and
  - .5 safe states for each function implemented.

## 10.2 MANAGEMENT AND CONTROL OF BALLAST WATER AND SEDIMENTS

### 10.2.1 Ballast water management plan

Each ship shall have on board and implement a Ballast water management plan. Such a plan shall be approved by the *RO* taking into account Guidelines for ballast water management and development of ballast water management plans (G4), IMO Res. MEPC.127(53). The Ballast water management plan shall be specific to each ship and shall at least:

- .1 detail safety procedures for the ship and the crew associated with ballast water management;
- .2 provide a detailed description of the actions to be taken to implement the ballast water management requirements and supplemental ballast water management practices;
- .3 detail the procedures for the disposal of sediments at sea and to shore;
- .4 include the procedures for coordinating shipboard ballast water management that involves discharge to the sea with the authorities of the state into whose waters such discharge will take place;
- .5 designate the officer on board in charge of ensuring that the plan is properly implemented;
- .6 contain the reporting requirements for ships; and
- .7 be written in the working language of the ship. If the language used is not English, French or Spanish, a translation into one of these languages shall be included.

### 10.2.2. Ballast water record book

- .1 Each ship shall have on board a Ballast water record book that may be an electronic record system, or that may be integrated into another record book or system.
- .2 Ballast water record book entries shall be maintained on board the ship for a minimum period of two years after the last en-

try has been made and thereafter in the company's control for a minimum period of three years.

- .3 Each operation concerning ballast water shall be fully recorded without delay in the Ballast water record book. Each entry shall be signed by the officer in charge of the operation concerned and each completed page shall be signed by the master. The entries in the Ballast water record book shall be in a working language of the ship. If that language is not English, French or Spanish the entries shall contain a translation into one of those languages.

### 10.2.3 Ballast water management for ships

- .1 A ship constructed before 2009:
  - .1 with a ballast water capacity of between 1500 and 5000 cubic metres, inclusive, shall conduct ballast water management that at least meets the standard described in 10.2.6 or 10.2.7 until the date of the renewal survey for the ship described in paragraph 10, after which time it shall at least meet the standard described in 10.2.7;
  - .2 with a ballast water capacity of less than 1500 or greater than 5000 cubic metres shall conduct ballast water management that at least meets the standard described in 10.2.6 or 10.2.7 until the date of the renewal survey for the ship described in paragraph 10, after which time it shall at least meet the standard described in 10.2.7.
- .2 A ship constructed in or after 2009 and before 8<sup>th</sup> September 2017, with a ballast water capacity of less than 5000 cubic metres shall conduct ballast water management that at least meets the standard described in 10.2.7, from the date of the renewal survey for the ship described in paragraph 10.
- .3 A ship constructed in or after 2009, but before 2012, with a ballast water capacity of 5000 cubic metres or more shall conduct ballast water management that at least meets the standard described in 10.2.6 or 10.2.7 until the date of the renewal survey for the ship described in paragraph 10, after which time it shall at least meet the standard described in 10.2.7.
- .4 A ship constructed in or after 2012 and before 8<sup>th</sup> September 2017 with a ballast water capacity of 5000 cubic metres or more shall conduct ballast water management that at least meets the standard described in 10.2.7, from the date of the renewal survey for the ship described in paragraph 10.
- .5 A ship constructed on or after 8<sup>th</sup> September 2017 shall conduct ballast water man-

agement that at least meets the standard described in 10.2.7.

- .6 The requirements of 10.2.3 do not apply to ships that discharge ballast water to a reception facility designed taking into account the Guidelines for ballast water reception facilities (G5), IMO Res. MEPC.153(55).
- .7 Other methods of ballast water management may be accepted as alternatives to the standards described in 10.2.6 or 10.2.7, provided that such methods ensure at least the same level of protection to the environment, human health, property or resources, and are approved by the Organisation in accordance with Resolution MEPC.206(62).
- .8 Ship constructed before 8th September 2017 to which the renewal survey described in paragraph 10 does not apply, shall conduct ballast water management that at least meets the standard described in 10.2.7 not later than 8 September 2024.
- .9 Ships subject to 10.2.3.2, 10.2.3.4 or 10.2.3.8 shall comply with either standard described in 10.2.6 or 10.2.7, until such time after which they shall comply with standard described in 10.2.7.
- .10 Renewal survey in 10.2.3.1, 10.2.3.2, 10.2.3.3 and 10.2.3.4 is:
  - .1 the first renewal survey for the ship associated with the IOPP certificate on or after 8 September 2017 if:
    - .1 this survey is completed on or after 8 September 2019; or
    - .2 a renewal survey is completed on or after 8th September 2014 but prior to 8th September 2017; and
  - .2 the second renewal survey for the ship associated with the IOPP certificate on or after 8th September 2017 if the first renewal survey on or after 8th September 2017 is completed prior to 8th September 2019.

#### 10.2.4 Ballast water exchange

- .1 A ship conducting ballast water exchange to meet the standard in 10.2.6 shall:
  - .1 whenever possible, conduct such ballast water exchange at least 200 nautical miles from the nearest land and in water at least 200 metres in depth, taking into account the Guidelines for ballast water exchange (G6), IMO Res. MEPC.288(71);
  - .2 in cases where the ship is unable to conduct ballast water exchange in accordance with paragraph 1.1, such ballast water exchange shall be conducted taking into account the Guidelines (G6) and as far from the nearest land as possible, and in all cases at least 50 nautical miles from the near-

est land and in water at least 200 metres in depth.

- .2 In sea areas where the distance from the nearest land or the depth does not meet the parameters described in paragraph 1.1 or 1.2, the port state may designate areas, in consultation with adjacent or other states, as appropriate, where a ship may conduct ballast water exchange, taking into account the Guidelines (G6).
- .3 Ships shall, without compromising safety or operational efficiency, be designed and constructed with a view to perform safe, environmentally acceptable, technically achievable, practicable and cost effective ballast water exchange, taking into account Guidelines for ballast water exchange design and construction standards (G11), IMO Res. MEPC.149(55).
- .4 When undertaking ballast water exchange operations master shall take into account guidelines in MSC/Circ.1145.

#### 10.2.5 Sediment management for ships

- .1 All ships shall remove and dispose of sediments, from spaces designated to carry ballast water in accordance with the provisions of the ship's Ballast water management plan, to reception facilities designed taking into account the Guidelines for sediment reception facilities (G1), IMO Res. MEPC.152(55).
- .2 Ships described in 10.2.3.3 to 10.2.3.6 shall, without compromising safety or operational efficiency, be designed and constructed with a view to minimize the uptake and undesirable entrapment of sediments, facilitate removal of sediments, and provide safe access to allow for sediment removal and sampling, taking into account Guidelines on design and construction to facilitate sediment control on ships (G12), IMO Res. MEPC.209(63). Ships described in 10.2.3.1 shall, to the extent practicable, comply with this paragraph.

#### 10.2.6 Ballast water exchange standard

- .1 Ships performing ballast water exchange in accordance with 10.2.6 shall do so with an efficiency of at least 95 percent volumetric exchange of ballast water.
- .2 For ships exchanging ballast water by the pumping-through method, pumping through three times the volume of each ballast water tank shall be considered to meet the standard described in paragraph 1. Pumping through less than three times the volume may be accepted provided the ship can demonstrate that at least 95 percent volumetric exchange is met.

### 10.2.7 Ballast water performance standard

- .1 Ships conducting ballast water management in accordance with 10.2.7 shall discharge less than 10 viable organisms per cubic metre greater than or equal to 50 micrometres in minimum dimension and less than 10 viable organisms per millilitre less than 50 micrometres in minimum dimension and greater than or equal to 10 micrometres in minimum dimension; and discharge of the indicator microbes shall not exceed the specified concentrations described in paragraph 2.
- .2 Indicator microbes, as a human health standard, shall include:
  - .1 Toxicogenic *Vibrio cholerae* (O1 and O139) with less than 1 colony forming unit (cfu) per 100 millilitres or less than 1 cfu per 1 gram (wet weight) zooplankton samples ;
  - .2 *Escherichia coli* less than 250 cfu per 100 millilitres;
  - .3 Intestinal *Enterococci* less than 100 cfu per 100 millilitres.

### 10.2.8 Approval requirements for ballast water management systems

- .1 Except as specified in paragraph 2, ballast water management systems used to comply with this Chapter must be approved by the *Register*, as follows:
  - .1 taking into account Guidelines for approval of ballast water management systems (G8), IMO Res. MEPC.279(70), for systems installed before 28 October 2020.
  - .2 taking into account Code for approval of ballast water management systems (BWMS Code), IMO Res. MEPC.300(72), for systems installed on or after 28th October 2020.
- .2 Ballast water management systems which make use of active substances or preparations containing one or more active substances to comply with this Chapter shall be approved by the Organization, based on the Procedure for approval of ballast water management systems that make use of active substances (G9), IMO Res. MEPC.169(57).  
This procedure describes the approval and withdrawal of approval of active substances and their proposed manner of application. At withdrawal of approval, the use of the relevant active substance or substances shall be prohibited within 1 year after the date of such withdrawal.
- .3 Ballast water management systems used to comply with this Chapter must be safe in terms of the ship, its equipment and the crew.

### 10.2.9 Prototype ballast water treatment technologies

- .1 For any ship that, prior to the date that the standard in 10.2.7 would otherwise become effective for it, participates in a programme approved by the *Register* to test and evaluate promising ballast water treatment technologies, the standard in 10.2.7 shall not apply to that ship until five years from the date on which the ship would otherwise be required to comply with such standard.
- .2 For any ship that, after the date on which the standard in 10.2.7 has become effective for it, participates in a programme approved by the *Register*, taking into account Guidelines for approval and oversight of prototype ballast water treatment technology programmes (G10), IMO Res. MEPC.140(54), to test and evaluate promising ballast water technologies with the potential to result in treatment technologies achieving a standard higher than that in 10.2.7, the standard in 10.2.7 shall cease to apply to that ship for five years from the date of installation of such technology.
- .3 In establishing and carrying out any programme to test and evaluate promising ballast water technologies, parties shall:
  - .1 take into account Guidelines (G10), and
  - .2 allow participation only by the minimum number of ships necessary to effectively test such technologies.
- .4 Throughout the test and evaluation period, the treatment system must be operated consistently and as designed.

## 10.3 BALLAST WATER MANAGEMENT SYSTEMS

**10.3.1** The BWMS shall not contain or use any substance of a dangerous nature, unless adequate arrangements for storage, application, **installation** and safe handling, acceptable to the *Register*, are provided to mitigate any hazards introduced thereby.

**10.3.2** In case of any failure compromising the proper operation of the BWMS, audible and visual alarm signals shall be given in all stations from which ballast water operations are controlled.

**10.3.3** All working parts of the BWMS that are liable to wear or to be damaged shall be easily accessible for maintenance. The routine maintenance of the BWMS and troubleshooting procedures shall be clearly defined by the manufacturer in the operating and maintenance manual. All maintenance and repairs shall be recorded.

**10.3.4** To avoid interference with the BWMS, the following items shall be included:

- .1 every access of the BWMS beyond the essential requirements of paragraph 10.3.3, shall require the breaking of a seal;
- .2 if applicable, the BWMS shall be so constructed that a visual **indication** is always activated whenever the BWMS is in operation for purposes of cleaning, calibration, or repair, and these events shall be recorded by the control equipment;
- .3** any bypass of the BWMS shall activate an alarm, and the bypass event shall be recorded by the control equipment.

**10.3.5** Facilities shall be provided for checking, at the renewal surveys and according to the manufacturer's instructions, the performance of the BWMS components that take measurements. A calibration certificate certifying the date of the last calibration check, shall be retained on board for inspection purposes. Only the manufacturer or persons authorized by the manufacturer shall perform the accuracy checks.

### 10.3.6 Ballast water treatment equipment

- .1 The ballast water treatment equipment shall be robust and suitable for working in the shipboard environment, shall be of a design and construction adequate for the service for which it is intended and shall be so installed and protected as to reduce to a minimum any danger to persons on board. **Equipment that could emit dangerous gases / liquids shall have at least two independent means of detection and shut-down of the BWMS.** Materials used in construction **shall be compatible with the substances used**, the purpose for which the equipment is intended, the working conditions to which it will be subjected and the environmental conditions on board.

- .2 The ballast water treatment equipment shall be provided with simple and effective means for its operation and control. It shall be provided with a control system that shall be such that the services needed for the proper operation of the ballast water treatment equipment are ensured through the necessary arrangements.
- .3 The ballast water treatment equipment shall, if intended to be fitted in locations where flammable atmospheres may be present, comply with the relevant safety regulations for such spaces. Any electrical equipment that is part of the BWMS shall be based in a non-hazardous area, or shall be certified by the *Register* as safe for use in a hazardous area. Any moving parts, which are fitted in hazardous areas, shall be arranged so as to avoid the formation of static electricity.
- .4 BWMS shall be designed so as not to endanger the health and safety of the crew, interact negatively with the ship's systems and cargo or produce any adverse environmental effects. The BWMS shall not create long-term impacts on the safety of the ship and crew through corrosive effects in the ballast system and other spaces.**
- .5 It shall be demonstrated, by using mathematical modelling and/or calculations, that any up or down scaling of the BWMS will not affect the functioning and effectiveness on board a ship of the type and size for which the equipment will be certified. In doing so, the manufacturer of the equipment shall take into account the guidance in BWM.2/Circ.33/Rev.1.**
- .6 Scaling information shall allow the Register to verify that any scaled model is at least as robust as the land-based-tested model. The Register shall verify that the scaling used is appropriate for the operational design of the BWMS.**
- .7 The shipboard test unit shall be of a capacity that allows for further validation of the mathematical modelling and/or calculations for scaling, and preferably selected at the upper limit of the rated capacity of the BWMS, unless otherwise approved by the Register.**

### 10.3.7 Control and monitoring equipment

- .1 BWMS shall have a suitable control and monitoring system that will automatically monitor and record sufficient data to verify correct operation of the system. The equipment shall be able to produce a report of the applicable self-monitoring parameters for official inspections or maintenance, as required. Where practical, system design limitation parameters shall be monitored and recorded by the**

BWMS to ensure proper operation (see BWM.2/Circ.69).

- 2 The BWMS shall incorporate control and monitoring equipment that automatically monitors and adjusts necessary treatment dosages or intensities or other aspects of the BWMS of the vessel, which while not directly effecting treatment, are nonetheless required for proper administration of the necessary treatment.
- 3 The monitoring equipment shall record the proper functioning or failure of the BWMS.
- 4 To facilitate compliance with 10.2.2, the control equipment shall also be able to store data for at least 24 months. In the event the control equipment is replaced, means shall be provided to ensure the data recorded prior to replacement remains available on board for 24 months.
- 5 All software changes introduced to the system after the pre-test evaluation shall be done according to a change handling procedure ensuring traceability.
- 6 For BWMS that could emit dangerous gases, means of gas detection by redundant safety systems shall be fitted in the space of the BWMS, and an audible and visual alarm shall be activated at a local area and at a manned BWMS control station in case of leakage. The gas detection device shall be designed and tested in accordance with IEC 60079-29-1 or other recognized standards acceptable to the Register. Monitoring measures for dangerous gases with independent shutdown shall be provided on the BWMS.

### 10.3.8 Installation requirements

- 1 The BWMS shall be provided with sampling facilities installed taking into account Guidelines (G2), so arranged in order to collect representative samples of the ship's ballast water discharge.
- 2 Suitable bypasses or overrides to protect the safety of the ship and personnel shall be installed and used in the event of an emergency and these shall be connected to the BWMS so that any bypass of the BWMS shall activate an alarm. The bypass event shall be recorded by the control and monitoring equipment and within the ballast water record book.  
This requirement does not apply to internal transfer of ballast water within the ship (anti-heeling operations). For BWMS that transfer water internally which may affect compliance with the standard in 10.2.7 (circulation or in-tank treatment), the recording required shall identify such internal transfer operations.
- 3 Installation of BWMS shall be in compliance with the *Rules for the classification of ships, Part 8 – Piping*, 3.5.

### 10.3.9 Workshop testing

Equipment, devices, systems and instrumentation after assembly shall be tested according to procedure in 10.1.4.3.9 approved by the Register. In special cases the Register may allow shipboard testing instead of workshop testing.

### 10.3.10 Installation survey and commissioning procedures

- 1 Verify that the following documentation is on board in a suitable format:
  - 1 a copy of the Type Approval Certificate of BWMS;
  - 2 a statement from Register or Flag State Administration, or from a laboratory authorized by the Register or Flag State Administration, to confirm that the electrical and electronic components of the BWMS have been type-tested in accordance with the specifications for environmental testing;
  - 3 equipment manuals for major components of the BWMS;
  - 4 an operations and technical manual for the BWMS specific to the ship and approved by the Register, containing a technical description of the BWMS, operational and maintenance procedures, and backup procedures in case of equipment malfunction;
  - 5 installation specifications;
  - 6 installation commissioning procedures; and
  - 7 initial calibration procedures.
- 2 Verify that:
  - 1 the BWMS installation has been carried out in accordance with the technical installation specification referred to in 10.3.10.1.5;
  - 2 the BWMS is in conformity with the Type Approval Certificate of BWMS issued by the Register or Flag State Administration;
  - 3 the installation of the complete BWMS has been carried out in accordance with the manufacturer's equipment specification;
  - 4 any operational inlets and outlets are located in the positions indicated on the drawing of the pumping and piping arrangements;
  - 5 the workmanship of the installation is satisfactory and, in particular, that any bulkhead penetrations or penetrations of the ballast system piping are to the relevant approved standards; and
  - 6 the installation commissioning procedures have been completed (see Guidance in BWM.2/Circ.70).